

**New product**

## CM-SB Series

Steel battery unit



### Features

- Steel housing with lightweight thermoplastic fully adjustable 2W, long life LED heads
- Suitable for wall mount application
- Fully adjustable LED glare-free lens
- Can power CM-R1 and CM-R2 remote fixtures only
- Standard 120/347VAC input with line cord kit
- Lead-acid battery
- Up to 120 minutes of emergency lighting
- Red LED charger monitor
- Momentary test switch allows for quick operational check
- CSA C22.2 no.141-15 certified
- **Warranty details at: [www.emergi-lite.ca](http://www.emergi-lite.ca)**



### Dimensions

Dimensions are approximate and subject to change.

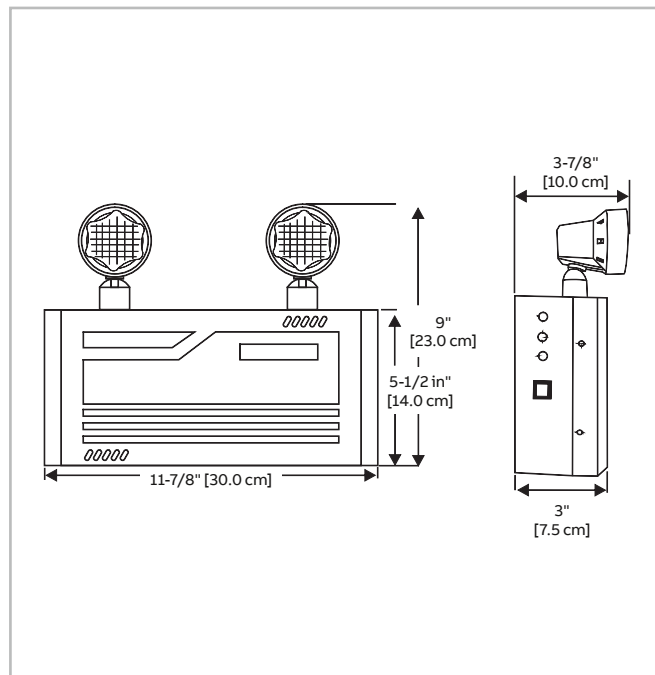

BATTERY UNITS

### Power consumption and unit rating

Model	AC specs			
	Wattage	Current	Efficiency	
CM-SB-E	120V, 50/60Hz	3.2W	0.03A	0.97PF
	277V, 50/60Hz	3.4W	0.014A	0.92PF
	347V, 50/60Hz	3.6W	0.01A	0.92PF

### Ordering information

Series	Voltage	Brand
CM-SB (27W)	Blank= 120VAC-347VAC	-E= Emergi-Lite®

Example: CM-SB-E