

1-5/8 in. x 1-5/8 in. Channel and Hardware

Superstrut® 1-5/8 in. x 1-5/8 in. - 12 Gauge Channel Type A

Solid Base

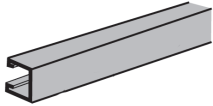

Half Slots

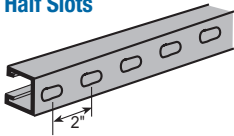

Knockouts

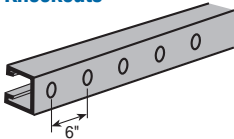

Punched

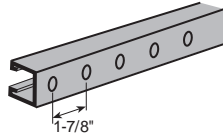

Long Slots

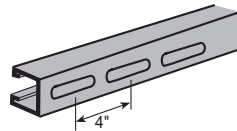

Back to Back



Cat. No.	Description
A1200	Solid base
A1200-P	Punched
A1200-HS	Half slots
A1200-S	Long slots
A1200-KO	Knockouts
A1202	Back to back

Example: A1200HS10ALC, A120020HDGC

Finishes & Materials

No Suffix	Gold galvanized dichromate finish
PGC	Pregalvanized
HDGC	Hot-dipped galvanized
T316L	Stainless steel type 316
ALC	Aluminum
EG	Electrogalvanized

- Offered in 10 or 20 ft. lengths.
- Aluminum, hot-dipped galvanized or stainless steel channels are recommended to support aluminum, steel or stainless steel cable tray.

Channel Nuts

A100 Regular Spring Nut

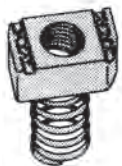

AC100 Springless Nut



UC100 Universal Nylon Cone Nut



For all 1-5/8 in. and 1-1/2 in. channels
May be used with ALL strut depths.

Cat. No.	Size	
A100-1/4EGC	1/4	Standard finish: Electrogalvanized Stainless steel channel nuts are recommended for aluminum channel and cable tray rungs. Change suffix to SS6(C).
A100-5/16EGC	5/16	
A100-3/8EGC	3/8	
A100-1/2EGC	1/2	
A100-5/8EGC	5/8	
A100-3/4	3/4	
A100-7/8EGC	7/8	

Nut is square over 1/2 in. size.

Cat. No.	Size	
AC100-1/4EGC	1/4	Standard Finish: Electrogalvanized Stainless steel channel nuts are recommended for aluminum channel and cable tray rungs. Change suffix to SS6(C).
AC100-3/8EGC	3/8	
AC100-1/2EGC	1/2	
AC100-5/8	5/8	
AC100-3/4	3/4	

Nut is square over 1/2 in. size.

Cat. No.	Size	
UC100-1/4	1/4	Not available in stainless steel.
UC100-3/8	3/8	
UC100-1/2	1/2	

Hex. Head Cap Screw

Cat. No.	Size	
E142-1/4x100EG	1/4 x 1	Standard finish: Electrogalvanized Available in stainless steel. Change suffix to SS6(C).
E142-1/4x150EG	1/4 x 1-1/2	
E142-3/8x100EG	3/8 x 1	
E142-3/8x150EG	3/8 x 1-1/2	
E142-1/2x100EG	1/2 x 1	
E142-1/2x150EG	1/2 x 1-1/2	



Fittings

Superstrut® Fittings and Brackets

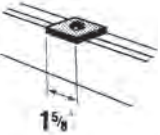
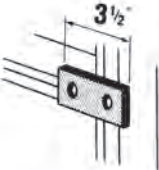
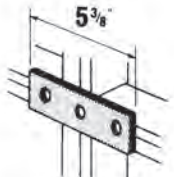
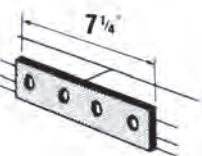
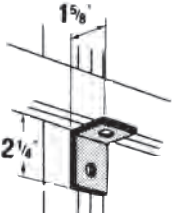
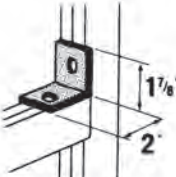
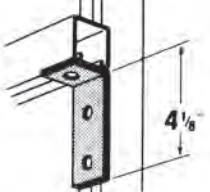
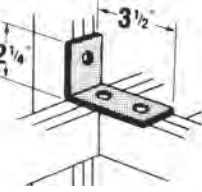
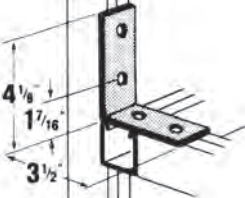
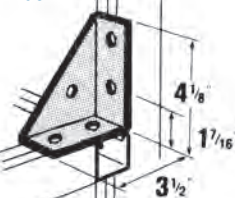
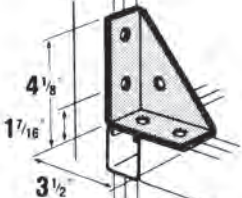
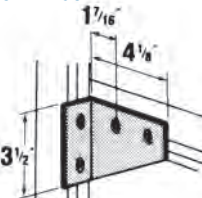
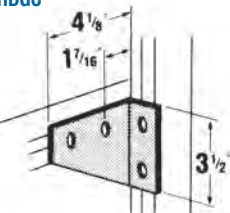
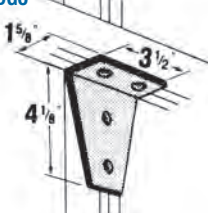
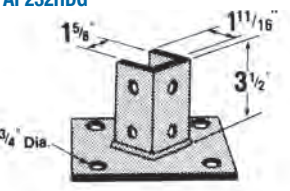
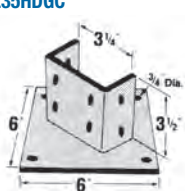
<p>AB241HDGC</p>  <table border="1" data-bbox="326 569 532 726"> <thead> <tr> <th>Cat. No.</th> <th>Hole Size</th> </tr> </thead> <tbody> <tr> <td>AB241-1/4HDGC</td> <td>1/4</td> </tr> <tr> <td>AB241-3/8HDGC</td> <td>3/8</td> </tr> <tr> <td>AB241-1/2HDGC</td> <td>1/2</td> </tr> <tr> <td>AB241-3/4HDGC</td> <td>3/4</td> </tr> </tbody> </table>	Cat. No.	Hole Size	AB241-1/4HDGC	1/4	AB241-3/8HDGC	3/8	AB241-1/2HDGC	1/2	AB241-3/4HDGC	3/4	<p>AB206HDGC</p> 	<p>AB207HDGC</p> 	<p>X207HDGC</p> 
Cat. No.	Hole Size												
AB241-1/4HDGC	1/4												
AB241-3/8HDGC	3/8												
AB241-1/2HDGC	1/2												
AB241-3/4HDGC	3/4												
<p>AB201HDGC</p> 	<p>AB202HDGC</p> 	<p>AB203HDGC</p> 	<p>AB204HDGC</p> 										
<p>AB205HDGC</p> 	<p>AB213HDGC</p> 	<p>AB214HDGC</p> 	<p>AB254-LHDGC</p> 										
<p>AB254-RHDGC</p> 	<p>X289HDGC</p> 	<p>AP232HDG</p> 	<p>AP235HDGC</p> 										

S249HDG



S256HDGC

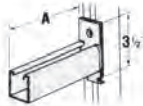

S251HDGC



Cat. No.	A	B	Design Load (lb.)
S249-8HDG	8-1/2	8	1500
S249-14HDG	14-1/2	9	1500
S249-20HDG	20-1/2	9	1500
S249-26HDG	26-1/2	11-1/2	1500
S249-32HDG	32-1/2	11-1/2	1500
S249-38HDG	38-1/2	11-1/2	1500

Cat. No.	A	Design Load (lb.)
S256-8HDG	8-1/2	1000
S256-14HDG	14-1/2	500
S256-20HDG	20-1/2	300
S256-26HDG	26-1/2	250

When installed in inverted position reduce load rating 40%. Strut section made from half slot channel.

Cat. No.	A	Design Load (lb.)
S251-14HDGC	14-1/2	1650
S251-20HDGC	20-1/2	1050
S251-26HDGC	26-1/2	800
S251-32HDGC	32-1/2	650
S251-38HDGC	38-1/2	500

Std Dimensions: Hole spacing 13/16 in. from end
Hole spacing 1-7/8 in. centers
Hole size 9/16 in. dia.
Fitting width 1-5/8 in.

Hot-dipped galvanized HDG(C) or stainless steel SS6(C) fittings are recommended to assemble aluminum channel. Also available in Electrogalvanized (EG) and Gold galvanized dichromate (no suffix).

Quick Clamp II (TBQC)



True one-piece construction — arrives ready to install.

NO breaking apart — half the installation time of break apart clamps.

Integral bolt and captive nut — no separate pieces to lose.

One size fits EMT and rigid conduit — takes the guesswork out of clamp selection. Pipe size and catalogue number stamped right on clamp.

Attaches a complete range of EMT and rigid conduit (1/2 in. to 4 in.) — to strut channels.

Multi-driver combo bolt head — accepts a wrench, most screwdrivers or 1/2 in. nut driver.

Field-adjustable angle ($\pm 4^\circ$) — easy installation even when strut is not square.

Embossed J-hooks increase loading capabilities.

T&B flex window provides wrapping action around pipes.

Easy reconfiguration without complete disassembly — easily accessible angled bolt allows for field adjustments and closer conduit spacing.

Electrogalvanized finish — additional corrosion resistance.

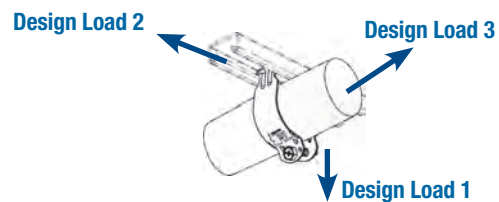
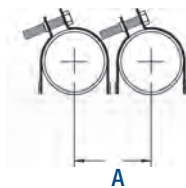

Ordering Information

Cat. No.	EMT Dimension A in. (mm)	Rigid Conduit Dimension A in. (mm)
TBQC050	1-5/16 (33.5)	1-1/4 (31.5)
TBQC075	1-3/4 (44.5)	1-11/16 (43)
TBQC100	1-13/16 (46)	1-3/4 (44.5)
TBQC125	2-1/8 (54)	2 (51)
TBQC150	2-3/8 (60.5)	2-3/16 (55.5)
TBQC200	2-5/8 (66.5)	2-1/2 (63.5)
TBQC250	3-1/16 (78)	3-1/16 (78)
TBQC300	3-11/16 (93.5)	3-11/16 (93.5)
TBQC350	4-3/16 (106.5)	4-3/16 (106.5)
TBQC400	4-11/16 (119)	4-11/16 (119)

Loading Data

Cat. No.	Design Load 1 Static Load Limit lb. (kg)	Design Load 2 lb. (kg)	Design Load 3 lb. (kg)
TBQC050	200 (90)	50 (23)	50 (23)
TBQC075	200 (90)	50 (23)	50 (23)
TBQC100	200 (90)	50 (23)	50 (23)
TBQC125	200 (90)	50 (23)	50 (23)
TBQC150	200 (90)	50 (23)	50 (23)
TBQC200	200 (90)	50 (23)	50 (23)
TBQC250	350 (158)	50 (23)	50 (23)
TBQC300	350 (158)	50 (23)	50 (23)
TBQC350	350 (158)	50 (23)	50 (23)
TBQC400	350 (158)	50 (23)	50 (23)

Design load 1 has a safety factor of 4. Design loads 2 and 3 have a safety factor of 1.

Cobra® Cable and Pipe Clamp (CPC)

Clear markings on each clamp — identify the catalogue number, min./max. outer cable diameters, EMT/Rigid trade sizes, CSA and UL stamps.

One size clamp works on **equal trade sizes for both EMT and rigid conduit.**

Works with **all depths of strut - 13/16 in. to 3-1/4 in.**

Two hooks on the same side — make the clamp easy to install and keep conduits and cable square with strut.

Rugged stirrup and wide saddle design — holds securely with no damage to conduit or cable.

Suggested design load is 200 lb. (1/2 in. to 2 in.); 350 lb. (2-1/2 in. to 4 in.). Safety factor 4:1 (safety factor = ratio of ultimate load to the design load).

Heavy-duty 5/16 in. hex bolt — with multi-driver head (Robertson square, Phillips cross-recess and slot) provides full range of installation options. Virtually any tool will work!

Bright zinc finish clamps are electrogalvanized after fabrication for additional durability.

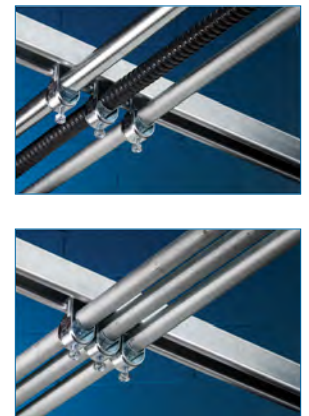
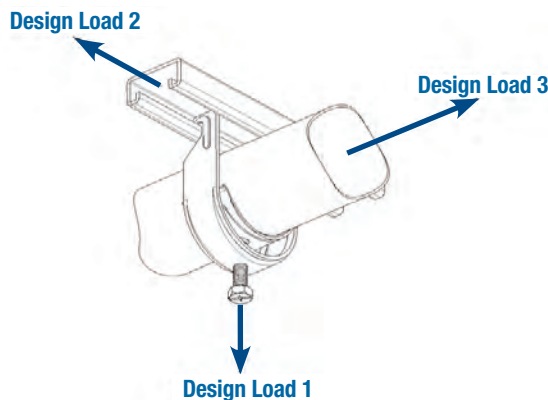

Cat. No.	Aluminum Cat. No.	Stainless steel 316L Cat. No.	EMT Trade Size in. (mm)	Rigid Cond. Trade Size in. (mm)	Cable O.D. Range (in.)	Static Load Limit (lb.) Safety Factor = 4	Qty. per Box	Wt./C lb.	Torque Value (ft.-lb.)
CPC025	CPC025AL	CPC025SS6	1/4 (6.4)	1/4 (6.4)	0.312 - 0.600	200	100	8	35
CPC050	CPC050AL	CPC050SS6	1/2 (12.7)	1/2 (12.7)	0.500 - 0.890	200	100	10	
CPC075	CPC075AL	CPC075SS6	3/4 (19.1)	3/4 (19.1)	0.860 - 1.110	200	100	12	
CPC100	CPC100AL	CPC100SS6	1 (25.4)	1 (25.4)	1.100 - 1.400	200	100	14	
CPC125	CPC125AL	CPC125SS6	1-1/4 (31.8)	1-1/4 (31.8)	1.400 - 1.725	200	50	16	
CPC150	CPC150AL	CPC150SS6	1-1/2 (38.1)	1-1/2 (38.1)	1.690 - 1.980	200	50	18	
CPC200	CPC200AL	CPC200SS6	2 (50.8)	2 (50.8)	1.980 - 2.576	200	50	24	
CPC250	CPC250AL	CPC250SS6	2-1/2 (63.5)	2-1/2 (63.5)	2.576 - 3.060	350	25	36	
CPC300	CPC300AL	CPC300SS6	3 (76.2)	3 (76.2)	3.060 - 3.626	350	25	42	
CPC350	CPC350AL	CPC350SS6	3-1/2 (88.9)	3-1/2 (88.9)	3.626 - 4.126	350	25	46	
CPC400	CPC400AL	CPC400SS6	4 (101.6)	4 (101.6)	4.126 - 4.626	350	25	50	

Design Load 1 Static Load Limit lb. (kg)	Design Load 2 lb. (kg)	Design Load 3 lb. (kg)
200 (91)	50 (23)	50 (23)
200 (91)		
200 (91)		
200 (91)		
200 (91)		
200 (91)		
200 (91)		
350 (159)		
350 (159)		
350 (159)		
350 (159)		
350 (159)		
350 (159)		
350 (159)		
350 (159)		

Standard material is commercial-grade, bright electrogalvanized steel. Stainless steel 316L is also available; add the suffix "SS6" to catalogue no. (i.e.: CPC050SS6).
Stainless steel bolt head is hexagonal and slotted only.

Loc-King Cobra™ Cable and Pipe Clamp (LKPC)



Superior design load capabilities for industrial applications:

350 lb. for 1/2 in. to 2 in. trade sizes; 450 lb. for 2-1/2 in. to 4 in. trade sizes.

- Durable one-piece, heavy-duty steel construction – designed specifically for use in industrial applications.
- Embosses on shoulder and hooks increase loading capability and durability, preventing deformation of clamps.
- Rugged stirrup provides increased strength for heavier loads, minimizing deflection.
- Wider saddle design with anti-rotation tabs distributes load evenly over a larger surface area, preventing jacket damage.
- Increased corrosion protection - GoldGalv® (yellow zinc dichromate) finish stands up to harsh industrial applications. Compared to conventional electrogalvanization.
- Parallel hook design keeps conduit and cable square with strut.
- Heavy-duty 5/16 in. hex bolt.
- One size clamp works on equal trade sizes for both EMT and rigid conduit, simplifying clamp specification.

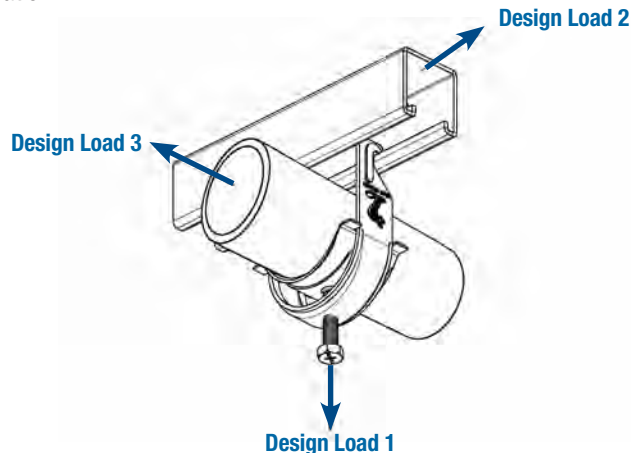

Cat. No.	EMT Trade Size in. (mm)	Rigid Cond. Trade Size in. (mm)	Cable O.D. Range (in.)	Static Load Limit (lb.) Safety Factor = 4	Qty. per Box	Wt./C lb.	Torque Value (ft.-lb.)
LKPC050	1/2 (12.7)	1/2 (12.7)	0.650 - 0.890	100	15	10	35
LKPC075	3/4 (19.1)	3/4 (19.1)	0.860 - 1.110	100	16	12	
LKPC100	1 (25.4)	1 (25.4)	1.100 - 1.400	50	19	14	
LKPC125	1-1/4 (31.8)	1-1/4 (31.8)	1.400 - 1.725	50	23	16	
LKPC150	1-1/2 (38.1)	1-1/2 (38.1)	1.690 - 1.980	50	27	18	
LKPC200	2 (50.8)	2 (50.8)	1.980 - 2.576	50	38	24	
LKPC250	2-1/2 (63.5)	2-1/2 (63.5)	2.576 - 3.060	25	44	36	
LKPC300	3 (76.2)	3 (76.2)	3.060 - 3.626	25	53	42	
LKPC350	3-1/2 (88.9)	3-1/2 (88.9)	3.626 - 4.126	25	58	46	
LKPC400	4 (101.6)	4 (101.6)	4.126 - 4.626	25	66	50	

Design Load 1 Static Load Limit lb. (kg)	Design Load 2 lb. (kg)	Design Load 3 lb. (kg)
350 (159)	50 (23)	50 (23)
350 (159)		
350 (159)		
350 (159)		
350 (159)		
350 (159)		
350 (159)		
450 (204)		
450 (204)		
450 (204)		



Beam Clamps and Hanger Rods

U562HDG

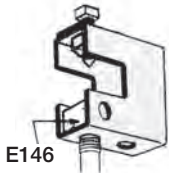

Rod Size	Design Load Load/lb.
1/2	800

E146 Square nut order separately. 1/2 in. set screw included.

For 20° swivel application use ES145-1/2 nut.

UM562HDGC

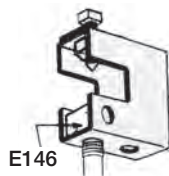

Rod Size	Design Load Load/lb.
1/2	1200

E146 Square nut order separately. 1/2 in. set screw included.

For 20° swivel application use ES145-1/2 nut.

US562HDGC

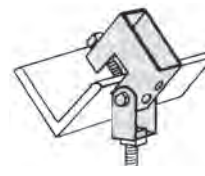

Rod Size	Design Load Load/lb.
1/2	800

1/2 in. set screw included.

U568

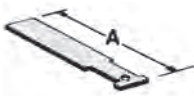

Cat. No.	Beam Flange Width	A
U568-3EG	6	9
U568-4EG	9	12
U568-5EG	12	15

16 ga. material.

U514HDGC

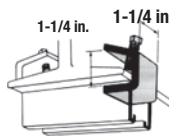

3/8 in. x 1-1/2 in. set screw included.

Design load 750 lb./per pair.

U515HDGC

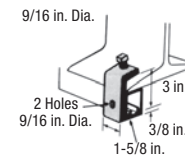

For all A series channel. 1/2 in. x 1-1/2 in. set screw included. Design load 800 lb.

ES145

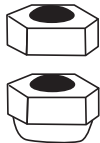

Cat. No.	Size
ES145-3/8EG	3/8
ES145-1/2EG	1/2

E146



Cat. No.	Size
E146-1/4EG	1/4
E146-5/16EG	5/16
E146-3/8EG	3/8
E146-1/2EG	1/2
E146-5/8EG	5/8

H104



Cat. No.	Size	Threads per inch	Design Load lb.
National Coarse Thread			
H104-1/4x10EGC	1/4	20	150
H104-3/8x10EGC	3/8	16	610
H104-1/2x10EGC	1/2	13	1130
H104-5/8x10EGC	5/8	11	1810
H104-3/4x10EGC	3/4	10	2710
H104-7/8x10EGC	7/8	9	3770

Also available in stainless steel (304 and 316) in length of 6 ft. Standard length 10 ft.

H119

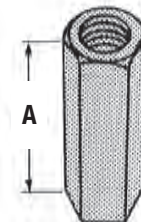

Rod Size	A
1/4	7/8
5/16	7/8
3/8	1-1/8
1/2	1-1/4
5/8	2-1/8
3/4	2-1/4
7/8	2-1/2
1	2-1/4

Order by product number, rod size, and finish. Example: H119-1/2EGC.

Design Applications / Mechanical Support

Example: 7

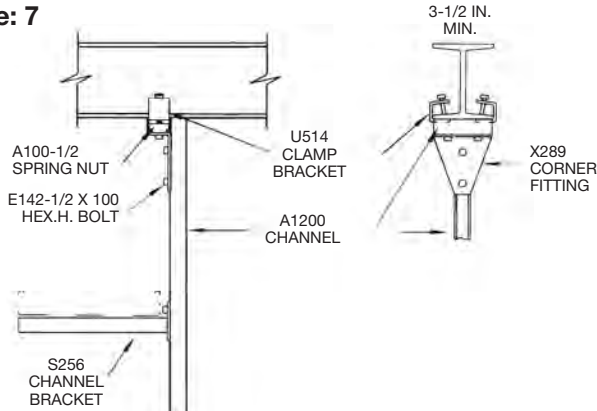

* NOTE: BRACE SHOULD BE USED FOR LENGTHS GREATER THEN 30 IN.

Single-sided bracket application

Example: 8

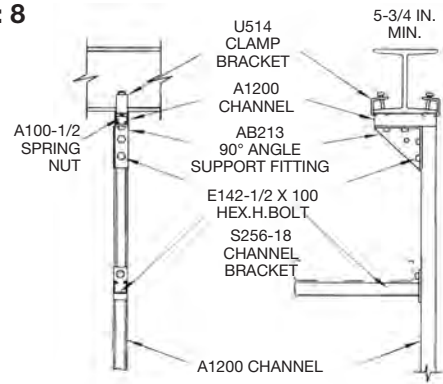

Single-sided bracket application

Example: 9

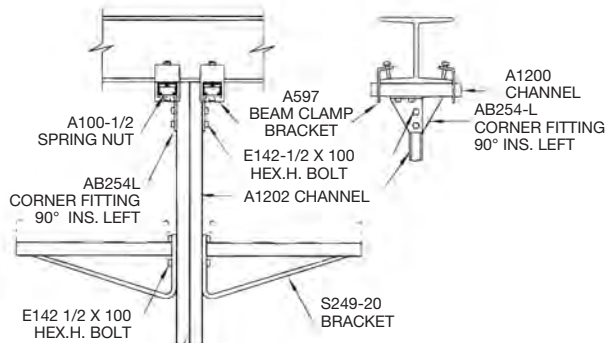

Two-sided heavy-duty application

Example: 10

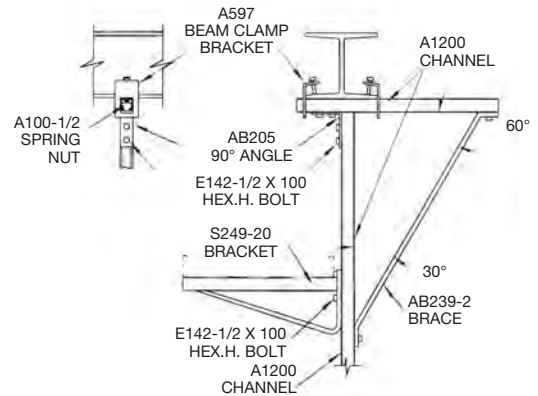

Heavy-duty bracket application

Example: 11

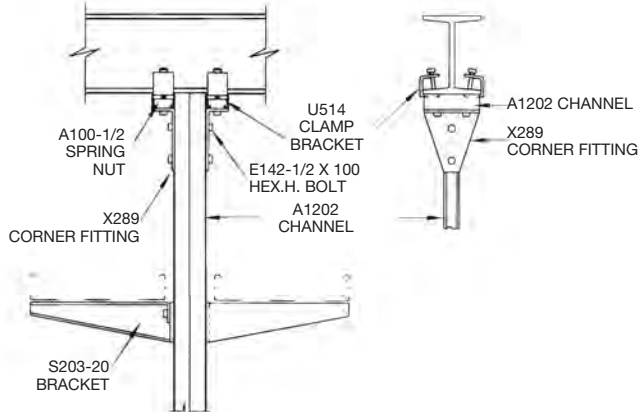

Brackets parallel to beam

Example: 12

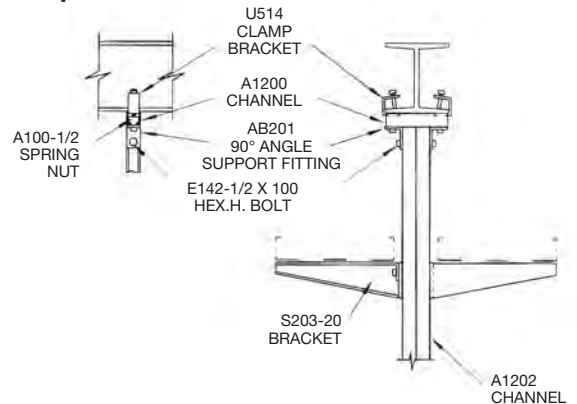

Brackets perpendicular to beam