



INTRODUCING THE  
NEW **MINI INVERTERS**  
BY LUMACELL®



**RELIABILITY THROUGH TECHNOLOGY**

# MAXIMIZE EFFICIENCY AND RELIABILITY WITH MINI INVERTER EMERGENCY POWER



As LED technology increases the efficacy of emergency lighting systems and decreases energy requirements, one Mini Inverter can supply power to an entire floor or large area when main power fails. A Mini Inverter-powered emergency lighting system requires fewer units and consumes less energy, making it an ideal choice for dependable, economical emergency power.

In commercial and harsh industrial environments, Lumacell® is known for durable, dependable specification-grade emergency lighting and exit signs. Lumacell® manufacturing and production operations in Canada ensure optimal lead time, service, and quality built in at every step.

## Discover the Advantages of Mini Inverters

One Mini Inverter can power multiple remote fixtures. The Lumacell® Mini Inverter provides 300W to 1440W of emergency power to exit signs and emergency lighting equipment for 30 minutes. One Mini Inverter fits in a small space and provides power to many remote fixtures, offering system flexibility. Additional Mini Inverters can be added exactly where needed to streamline the emergency lighting system. In large buildings, instead of requiring one large central emergency power system, Mini Inverters can be installed on each floor, optimizing space.

Existing fixtures can function as emergency lighting with a Mini Inverter. As an alternative to separate emergency lighting fixtures, normally-on light fixtures can be connected to the Mini Inverter so they will function in an emergency. For specifiers who wish to preserve a design aesthetic in high-visibility areas, this option is extremely valuable.

LED fixtures and most light sources run at 100% power in an emergency. With less than 1 second of transfer when power fails, the Mini Inverter provides 100% power/lumen output, making it ideal for LED fixtures. The Mini Inverter allows fixtures to be on, off, switched or dimmed (TRIAC dimming), and can be used with most light sources except HID.

## In an emergency, rest assured that the Mini Inverter is ready to power the emergency lighting system.

For additional reliability, the Nexus® monitoring and network management system can be connected to the Mini Inverter. Nexus® provides real-time assurance that the entire emergency lighting and exit sign system is ready for maximum safety and security.

Designed and manufactured for North American safety standards. Each Mini Inverter is cUL Listed and meets CSA141-15, and must pass strict in-house quality testing for North American standards. Lumacell® Mini Inverters use a long-life, maintenance-free, lead acid battery for reliability. Fully-featured self-diagnostics test all connected loads and batteries to ensure that when the main power fails, the emergency lighting system will be on.

Nexus® real-time monitoring system compatibility provides increased system reliability. The Mini Inverter is compatible with the Nexus® real-time monitoring and network management system, allowing inverter-powered exit signs and emergency lighting (including LED fixtures) to be managed using wireless communication and building automation. Diagnostics, monthly and annual functional tests required by building codes, maintenance logs, and compliance reports can all be run with the Nexus® system. Nexus® monitors total load on the mini-inverter from a central control unit. For locations interested in LEED certification and sustainability, the Nexus® system can contribute to achieving those objectives.

# RELIABILITY THROUGH TECHNOLOGY



# CHOOSING THE RIGHT BACKUP POWER SYSTEM

Back-up power can be provided in many ways. However, even though certain methods are suitable for critical applications, they may not be suitable for Emergency Lighting. This is because an Emergency Lighting system has unique load characteristics. Since Emergency Lighting is a critical life safety installation, it must be designed with its specific load characteristics in mind. Mini Inverter systems are specifically designed to provide emergency power for Emergency Lighting systems in a power failure.

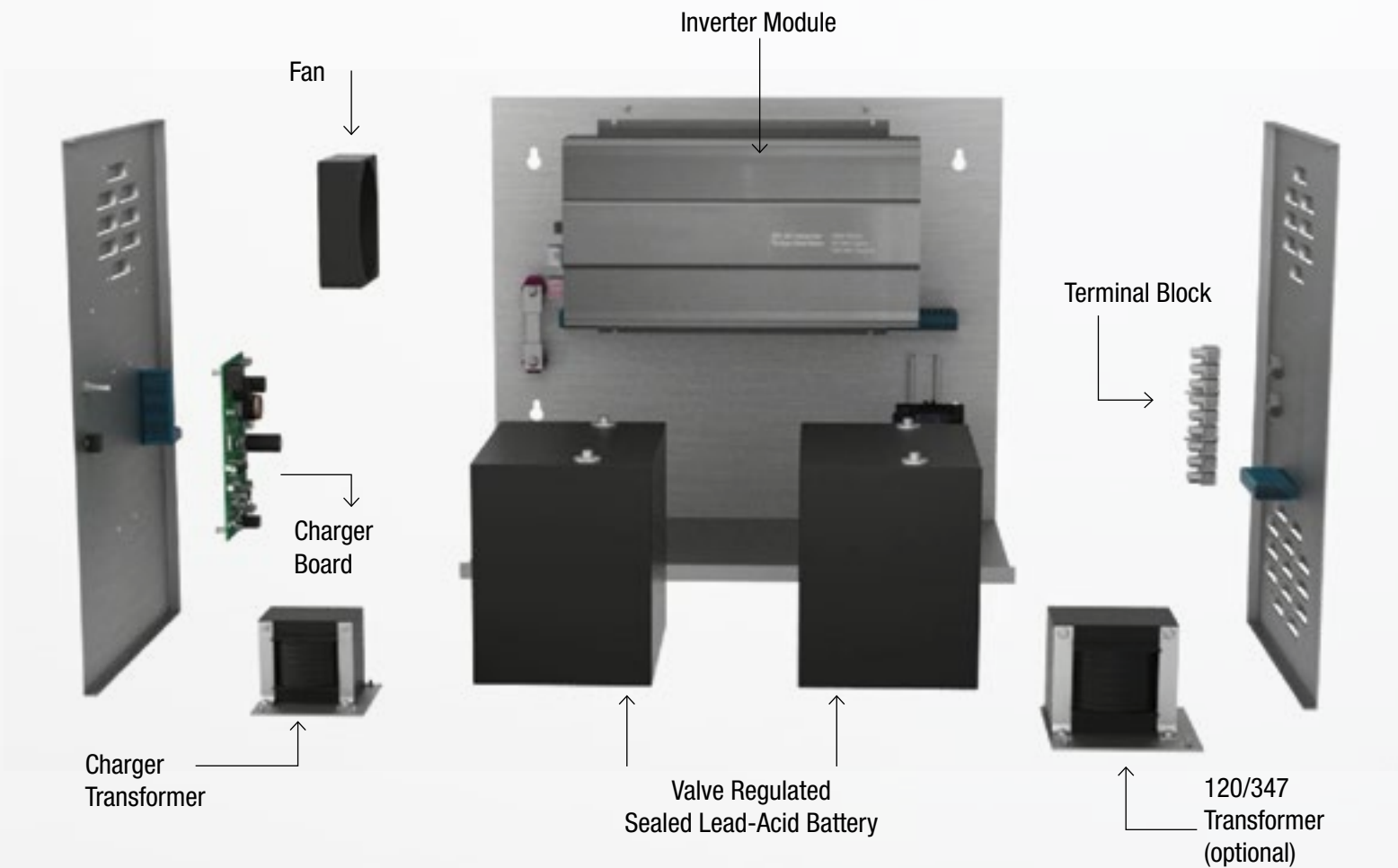



# MINI INVERTER FEATURES & BENEFITS



## FEATURES

### Self-Diagnostics/Self-Testing

The diagnostic/charger is a fully self-contained, fully automatic microcontroller-based system. Any fault condition causes a status LED indicator to blink, identifying the nature of the fault. Every 30 days, the sequence generator will generate a command to energize the transfer relay for a variable test period based on code requirements (1 minute each month, 10 minutes after 6 months, and 30 minutes after 12 months).

### System Design

Inverter and charger modules utilize highly reliable solid state electronics. The modules feature input and output protection, and they measure and limit their own current.

### Capacity

Capacity is available starting at 300W up to 1440W in 120V and 347V (347V not available in 300W)

### True Sine Waveform

Using a solid-state, pulse width modulation (PWM) inverter, Mini Inverter systems produce pure sinusoidal output waveform with less than 5% Total Harmonic Distortion (THD) for linear loads.

### Nexus Monitoring System

The Mini Inverter is compatible with Nexus®, a real-time monitoring system that manages the status of the total load on the mini-inverter from a central control unit. Nexus® runs diagnostics, performs required monthly and annual functional tests as per Building Codes, generates maintenance logs and runs compliance reports.

## BENEFITS

### Code Compliance

Reduces testing/service time for a minimal maintenance cost, while ensuring that local safety codes are met, and provides system reliability in a power failure condition.

### High Performance

The Mini Inverter is a rugged, easy-to-maintain system with exceptional performance for emergency lighting use. It offers overload performance without the need to over-specify the rating.

### Versatile Applications

Mini Inverter systems can be used in almost every type of building, and are ideal for architecturally sensitive applications or when maintenance costs and testing of individual unit equipment becomes significant. The smaller unit size of the Mini Inverter allows more flexibility and minimizes testing. It can be installed at a distance, offering the opportunity to hide the unit from view and maintain the architectural design by powering normally-on luminaires.

### Maximum Light Output

The Mini Inverter will deliver 100% power / lumen output of the fixture up to the specified run time. It is compatible with all fluorescent ballast, LED drivers or incandescent light sources.

### Reliability Through Technology

Nexus® allows for maintenance time and cost savings, and ensures that the emergency lighting fixtures will perform when needed. Nexus® can contribute to LEED certification and support sustainability objectives.



# Mini Inverter Series

Interruptible Unit Equipment

Type: \_\_\_\_\_  
 Project/Location: \_\_\_\_\_  
 Contractor: \_\_\_\_\_  
 Prepared By: \_\_\_\_\_  
 Date: \_\_\_\_\_  
 Model No.: \_\_\_\_\_

The **Mini-Inverter** is a cUL Listed stand-alone pure sine wave output inverter designed to provide power to designated emergency lighting fixtures. In a power loss situation, it will supply power from the onboard battery supply.

The **Mini-Inverter** works in conjunction with incandescent, LED, and fluorescent fixture types and will automatically run switched, normally-on, or normally-off designated emergency fixtures.

The **Mini-Inverter** is ideal for applications requiring an emergency source for lighting arrangements that utilize multiple lamp and fixture types and is available in surface mount and comes with a one year warranty and nine-year pro-rata battery warranty

## FEATURES

- Lamps operated: Incandescent LED, fluorescent lamps and ballast combinations, including TRIAC dimmable ballasts
- Components: High-efficiency pure sine wave inverter
- Temperature-compensated charger 12V oversized Valve Regulated Lead Acid (VRLA) battery
- Construction: 18-gauge steel for 300W & 600W/ 14-gauge steel for 1000W & 1440W
- Emergency lighting supplied from one convenient, reliable source
- Input/Output voltage 120/120V 60Hz or 347/347V 60 Hz
- Replaceable output fuse protection
- Valve Regulated Lead Acid (VRLA) battery provides long-life and is maintenance free
- Line voltage allows for remote mounting of emergency fixtures at distances up to 1000 feet
- Low Battery Voltage Disconnect
- Unit comes standard with electronic lockout and brownout circuits
- Meets or exceeds all National Electrical Code and Life Safety Code Emergency Lighting Requirements.
- Cabinet in factory white powder-coat paint finish
- **May accept load to it's full capacity when load feature power factor of 0.9 or more face**
- Non audible auto-test is standard.
- Nexus® system interface available
- Standard lighting control override for 0-10V dimming systems
- Meets or exceeds the requirements of CSA 141-15

## TYPICAL SPECIFICATIONS

Emergency lighting shall be provided by inverter unit equipment designed to operate designated incandescent, fluorescent and LED fixtures on emergency power at their full nominal lumen rating during the full 30 minute emergency discharge cycle. System output will be rated at \_\_\_\_\_ watts for 30 minutes and provide fused output connections to the load. The system's voltage rating shall be \_\_\_\_\_ VAC input/output nominal. The inverter unit shall allow for fused connected emergency fixture(s) to be normally on, normally off, switched or dimmed without affecting lamp operation during a power failure.

Upon utility power loss, the inverter unit shall deliver 100% of its rated output to the emergency fixtures regardless of the local switch or dimmer (TRIAC) position, and will provide power to emergency fixtures at distances of up to 1000 feet. The housing shall be manufactured using 18-gauge steel for 300W & 600W/ 14-gauge steel for 1000W & 1440W with a white baked-on powder coat paint finish.

The unit's electronics shall include a self-contained inverter section with a fully automatic, thermal-compensating variable-rate battery charger, AC lockout feature, low battery voltage disconnect, overload, short circuit and brownout protection as standard. The unit shall utilize a sealed lead acid battery with a 10-year design life. The inverter system shall be cUL Listed and labeled. The unit shall be covered under a 1-year warranty on the electronics and battery and a 9-year pro-rata warranty on the battery. It shall meet or exceed the requirements of CSA 141-15.

## SPECIFICATIONS

<b>TRANSFER TIME:</b> less than 1 second
<b>VOLTAGE REGULATION ON EMERGENCY:</b> +/- 3%
<b>FREQUENCY REGULATION ON EMERGENCY:</b> 60 Hz +/- 1%
<b>LOAD POWER FACTOR RANGE:</b> 0.9 leading to 0.9 lagging
<b>OPERATING TEMPERATURE:</b> 20° TO 30°C (68° TO 86°F)

## WARRANTY

All Lumacell® inverter products receive 100% quality inspection before shipment to insure proper and satisfactory operation. When operated under normal conditions, Lumacell® inverter products will provide years of dependable service. This unit is backed by a complete 1-year warranty against defects in material or workmanship, and a 9-year prorata battery warranty.

The inverter unit shall be Lumacell® model: \_\_\_\_\_.



## ELECTRICAL CHARACTERISTICS & DIMENSIONS

POWER RATING	MAX INPUT RATING		SINE WAVE	INSTALLATION	CABINET DIMENSIONS			NO. OF BATTERY	WEIGHT		WEIGHT W/O BATTERY	
	120VAC	347VAC			W"	H"	D"		120V	347V	120V	347V
300W	3.10	n/a	Pure	Wall	27"	12.25"	7.25"	1	55 lbs	n/a	30 lbs	n/a
600W	3.00	2.30	Pure	Wall	24"	20.25"	10.5"	2	105 lbs	117 lbs	55 lbs	67 lbs
1000W	11.60	3.60	Pure	Wall	24"	20.25"	14.5"	2	150 lbs	169 lbs	70 lbs	89 lbs
1440W	15.00	5.00	Pure	Wall	24"	20.25"	14.5"	2	190 lbs	214 lbs	75 lbs	99 lbs

Type: \_\_\_\_\_  
 Project/Location: \_\_\_\_\_  
 Contractor: \_\_\_\_\_  
 Prepared By: \_\_\_\_\_  
 Date: \_\_\_\_\_  
 Model No.: \_\_\_\_\_



# Mini Inverter Series

Interruptible Unit Equipment



## WIRING DIAGRAM

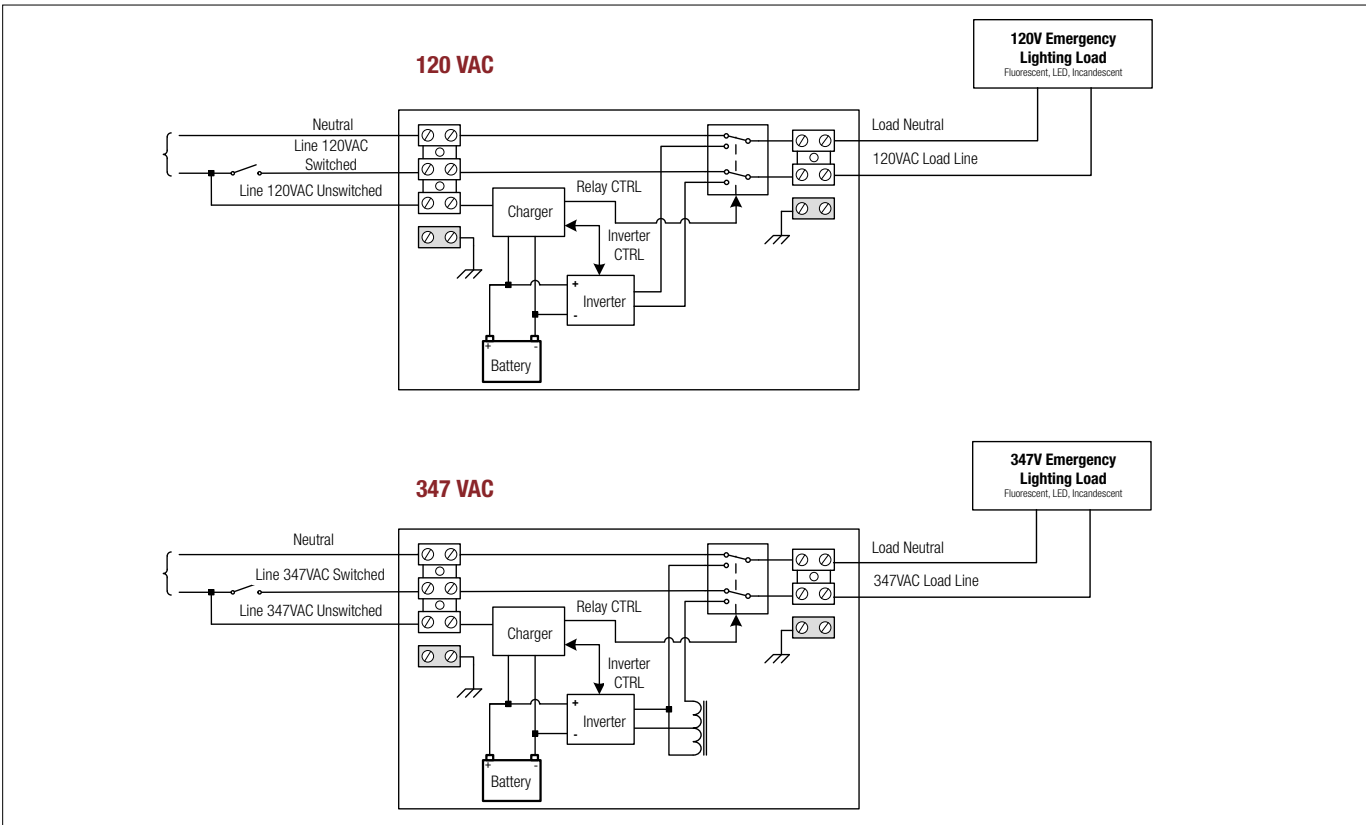

## POWER CONSUMPTION AND UNIT RATING

MODEL NUMBER	AC SPECS	EMERGENCY POWER AVAILABLE FOR LOAD				
		30MIN	1H00	1H30	2H00	4H00
LMI-300	120Vac 3.10 / Amps	300W	175W	125W	100W	50W
LMI-600	120 / 347Vac 6.00 / 2.30 Amps 11.60 / 3.60 Amps 15.00 / 5.00 Amps	600W	350W	250W	200W	100W
LMI-1000		1000W	585W	415W	330W	165W
LMI-1440		1440W	842W	600W	480W	240W

## ORDERING INFORMATION

SERIES	CAPACITY	VOLTAGES IN/OUT	DIAGNOSTIC FEATURES	OPTIONS
LMI= Series	-300= 300W -600= 600W -1000= 1000W -1440= 1440W	-1= 120/120VAC, 60 Hz -3= 347/347VAC, 60 Hz*	Blank= Auto-Diagnostics, non-audible* -AT= Auto-Diagnostics, audible* -NAT= No Diagnostics -NEX= Nexus® wired system interface** -NEXRF= Nexus® wireless system interface**	-LC= Line cord (120V only) -SAC= Service alarm contact -TL= Cord and twist lock plug (120V only) -T3= Time delay (15 minutes)
		* Available only with 600W, 1000W & 1440W	* Minimum load required: 10% of unit capacity ** Please consult your sales representative	

EXAMPLE: LMI-1440-1



[www.lumacell.com](http://www.lumacell.com)

All information and specifications contained in this flyer are subject to change due to engineer design, errors and omissions. Illustrations and diagrams within this flyer may vary from actual products.

© 2016. Thomas & Betts Limited. All rights reserved. Printed in Canada 10/15/3250.  
Order no. LU-MINIINVERTER-EN.