

B

Color-Keyed® - Compression connector systems



—

B

Color-Keyed - Compression connector systems

Table of contents

Section B

Overview	B4
Compression connectors for copper conductors	B12
H-tap connectors	B62
Wire joints for copper conductor	B66
Cast copper bus taps for copper conductor	B67
Motor pigtail connectors	B68
KUBE™ flag and tee connectors	B72
Connectors for aluminum/ copper code conductors	B74
Transformer lug kits	B81
Pin connectors	B82
H-tap insulating covers	B83
Parallel splices	B85
Heavy-duty battery/ connectors and tools	B86
Accessories and miscellaneous hardware	B94

Overview

The Color-Keyed method is better

The Color-Keyed method of installing compression connectors on power cables is designed to provide a high degree of reliability in electrical wiring.

This method allows electrical workers to make installations with little effort and at a considerable savings in time. The benefit, of course, is a high-quality connection at a low installed cost.

Blackburn connectors featuring the Color-Keyed system are banded by colored stripes or engraving to indicate location of die on connector for compression. ABB uses full-width and half-width dies dependent on connector size and tool used.

Half-width dies are marked with the letter “H” after the die code number. Refer to the instruction sheet supplied with the connectors for information regarding strip length, die selection and number of compressions required.

—
Just four easy steps to a perfect connection!



01

—
01 Strip the insulation
—
02 Stripping types and conductor connections

Step 1

Carefully strip the insulation on de-energized wires to avoid nicking or cutting conductors (wire brush if required).

Stripping types:

- **A** – Strand cut
- **B** – Nicked strands
- **C** – Good strip

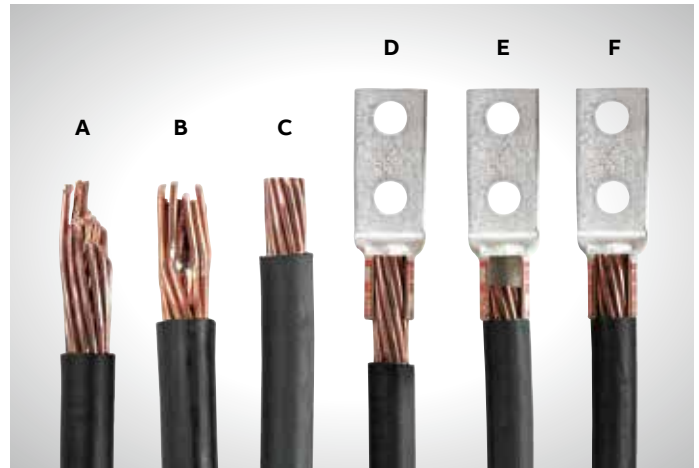

02

Strip the insulation to the proper length so that conductors can be fully inserted into the connector barrel.

Conductor connections:

- **D** – Strip length too long
- **E** – Strip length too short
- **F** – Strip length just right



03

- * Aluminum lugs with a "9" indicate 90 °C rating
- 03 Select the connector for the cable size
- 04 Connector types and markings

Step 2

Determine the proper Color-Keyed connector for the cable size being used. Connectors are marked to show cable size and material:

- **G** – Cable size
- **H** – Copper (die located BETWEEN bands)
- **I** – Aluminum (die located ON bands)

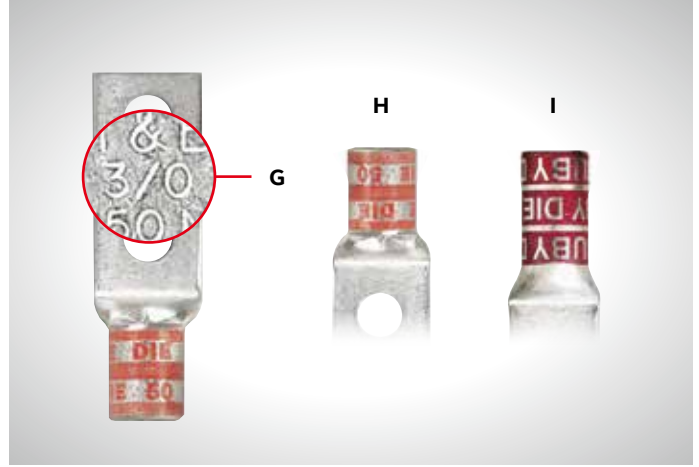

04

Connector types:

- Connectors marked with just cable size or CU should be used on copper conductors only
- Connectors marked "AL9" with the cable size should be used on aluminum conductors only
- Connectors marked "AL9CU" with the cable size may be used on aluminum or copper conductors



05

- 05 Select the installing die
- 06 Color-Keyed bands and die location for compression

Step 3

Select the proper installing die and appropriate tool. Blackburn connectors featuring the Color-Keyed system have colored bands or colored dots that correspond to color markings on the dies.

Connectors and dies also have a die code number marked or stamped on them. Dies have a code number engraved in the crimp surface.

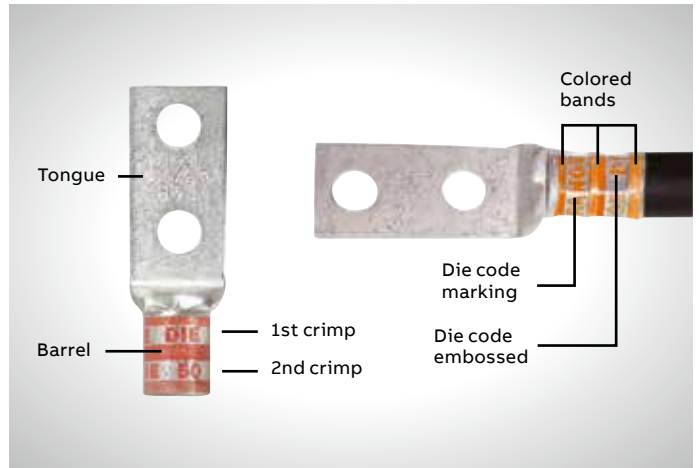

06

Step 4

Locate tool with correct die in proper position on connector and activate tool. When making multiple crimps, make the first crimp nearest the tongue and work towards the barrel end.

When properly crimped, the die code number will be embossed on the connector for easy inspection to determine if correct die and connector combination were used.

Overview

Precision dies for homogenous mass

The Color-Keyed method utilizing compression tools with matching dies forms the connector and conductor into a solid, homogenous mass to provide an optimum electrical bond between connector and conductor.

—
01 Locate tool with correct die in proper position on connector and activate tool.

—
02 Before compression, a typical cross section of cable and connector consists of about 75% metal and 25% air.

—
03 After air compression by the Color-Keyed method, the cross section looks like this, nearly 100% metal with virtually no air spaces.

Color-Keyed method dies are designed to produce a circumferential, hex- or diamond-shaped compression rather than a simple indent. Precision dies are an integral part of the ABB method.

The precision hardened steel dies exert tremendous, controlled pressure on the connector and conductor. The dies compress the connector around the cable, converting the round strands to hexagonal or diamond shapes and forming the strands and connector into a solid mass. Each die is designed so that all conductors receive the same amount of compression force.

The circumferential compression creates a large area of high-pressure contact between cable and connector which, in turn, assures high conductivity, low resistance, and high pullout values which exceed UL requirements. These features result in a permanent, low installed cost connection. You can install it, and forget it.

The Color-Keyed system tells you where to place the installing die

Blackburn connectors featuring the Color-Keyed system not only identify the correct installing die to be used for positive compressions, but also indicate the proper placement of the die on the connector. This is done by the bands of color on the connector which match the color on the dies. Compression is made between or on these color bands. The color name is also spelled on the connector as an added means of identification.

Color-Keyed dies offer inspection capability

Dies that are used in Color-Keyed hand and hydraulic tools contain the “die code” numbers which are engraved on the compression surface of the die. Under compression, this number becomes embossed on the completed connection for inspection purposes. The inspector compares the die code number embossed on the connector with the die table to ensure that the proper connector was compressed with the correct die for that particular size conductor.



—
02

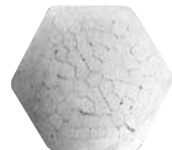

—
03



Battpac® LT Pump
350 kcmil AL. The battery-powered hydraulic pump, rated for 10,000 psi. Portable power for all Color-Keyed hydraulic heads, using just one Ni-MH 24V rechargeable battery.



TBM62PCR-LI
Designed for one-handed control ram advancement and retraction. Capacity up to Cu #8-600 kcmil Al #8-400 kcmil.



TBM6S Hand-operated crimping tool features Shure-Stake mechanism to ensure a completed crimp. For connectors up to 500 kcmil Cu, 350 kcmil Al.



Quality tooling with the Shure-Stake® mechanism

Color-Keyed manual tools with the exclusive Shure-Stake mechanism take the guesswork out of making compression connections. The Shure-Stake mechanism provides a full cycle compression stroke every time. Once the stroke has started, the tool will not release the connector until the proper amount of force has been applied. This is your assurance of a fully compressed connection. ABB compression tools develop uniform, controlled pressure to each connector within their size range. Color-Keyed offers electric and battery-powered hydraulic pumps with a Shure-Stake feature that guarantees a full cycle compression.

Color-Keyed method components meet industry standards

Depending on the application, all Color-Keyed copper connectors meet UL Std. 486A for code stranded and 24 gauge flex, CSA Std. C22.2, No. 65 600 V requirements for power and UL Std. 467, CSA Std. 22.2 No. 0.4 requirements for direct buried grounding.

Color-Keyed method connectors are available in a range of sizes and styles to accommodate #8 AWG through 1000 kcmil and larger copper or 2000 kcmil and larger aluminum cable. They may be compressed

on cable with either manual or hydraulic tools. They are offered with standard length or long barrels,

with one bolt or two bolt holes, or in two-way styles, for splicing applications. Two-way connectors are compact, providing high pullout values with low resistance.

Blackburn two-hole lugs featuring the Color-Keyed system are ideal for bus bar applications that require two bolts to prevent lug rotation. The Color-Keyed method is the most efficient, highest quality connection that has been engineered and delivers the best electrical performance and highest reliability.

Color-Keyed compression connectors eliminate risk of problems relating to loose connections when installed properly.

High-grade materials incorporated in Color-Keyed method

Low installed cost connections of superior quality can be achieved only through the use of high-grade components. That is an important part of the ABB method – quality products you can depend on.

Copper Blackburn connectors featuring the Color-Keyed system are made of high-conductivity wrought copper, and are electro tin plated to prevent corrosion and to improve conductivity. Color-Keyed Blackburn connectors featuring the Color-Keyed system offer the thickest tin plating in the industry. Other copper connectors for heavy-duty use and grid grounding applications are made of high-conductivity cast copper, bright finished.

High-conductivity cast aluminum connectors are available for heavy-duty application.

Overview

Special lugs – Angled, shaped and trimmed

ABB can solve your difficult wire bending and terminating problems in confined power distribution panels, switchgear and motor control enclosures.



— 01 Special lugs – Angled, shaped and trimmed

— 02 Examples of customized connectors for copper cables

We have the design and production capability to deliver exactly the type lug you need, shaped the way you need:

- Straight, 15°, 30°, 45°, 60° and 90° angle
- Stacking or non-stacking
- Narrow tongue or standard
- Tin, silver, lead, nickel

ABB offers an extensive line of copper Blackburn lugs featuring the Color-Keyed system for #8 AWG through 1000 kcmil flex and code cables. The lug tongues are modified in several different configurations to meet your exact needs: 45° and 90° bend angles, narrow tongues to fit into circuit breakers, offset tongues to stack two cables and special stud hole drilling.

These special configurations let you:

- 1) Run cable directly to the bus bar with no bending.
- 2) Terminate into very narrow spaces.
- 3) Utilize minimal bus bar space.

Customized connectors for copper cables

- Standard and special tongue angles, stacking and nonstacking, bolt holes sizes and centers, protective platings.
- Specially modified one- and two-hole copper compression lugs, series 54100, 54200, 54850BE and 54930BE for flex and code copper stranded cables. Material: high conductivity wrought copper.
- Minimum order quantity: Standard package quantity by cable size. Consult factory for price and delivery. All customized lugs are made to order. A.R.O. Non-cancelable.

— 01



— 02



Overview

Order form

Order form (For 54100, 54200, 54800 and 54900 series copper lugs only):

Catalogue number: **Quantity:**

Notes:

Notes:
 1) Lack of any of the extra features on the "MADE-UP" catalogue number means that the standard cat. no. features are prevalent.
 2) If either bolt hole size or distance between bolt holes needs to be changed from standard cat. no., both code numbers will appear on the "MADE-UP" cat. no. (See example below)

Code table

Tongue shape		Bolt holes		Bolt hole centers		Stacking		Finish (plating)		Inspection hole (long barrel)		Inspection hole (short barrel)	
Type	Code	Size	Code	Distance	Code	Type	Code	Type 1	Code	I.D.	Code	I.D.	Code
15°	UI	#8 0.173	02	½	08	Top	T**	Silver plate	SP	Peep hole	PH	Blind end	BE
30°	UT	#10 0.204	03	⅝	10	Bottom	B	Lead plate	LP			Bell ended	BS
45°	UF	¼ 0.281	04	¾	12			Nickel plate	NP	150°			
60°	US	⅝ 0.344	05	⅞	14			Plain finish	PF				
90°	UB	⅜ 0.406	06	1	16			No marking	NM				
Blank	BT	½ 0.531	08	1⅝	18								
(No bolt hole)		⅝ 0.656	10	1¾	20								
		¾ 0.812	12	1⅞	22								
		⅞ 0.937	14	1½	24								
		1 1.062	16	1⅝	26								
				1¾	28								
				1⅞*	30								
				2*	32								

Cable:

Code: **Weld:**

#8 #6 #4 #2 #1 1/0 2/0 3/0 4/0

250 kcmil and up (code only)

All "made-up" catalogue numbers start with a standard or basic catalogue number and are followed by the customer-required extra features: tongue shape, bolt hole size, distance between bolt holes, stacking, plating and inspection hole (peep hole). A code letter or a number has been assigned to each extra feature. See code table.

Diagrams

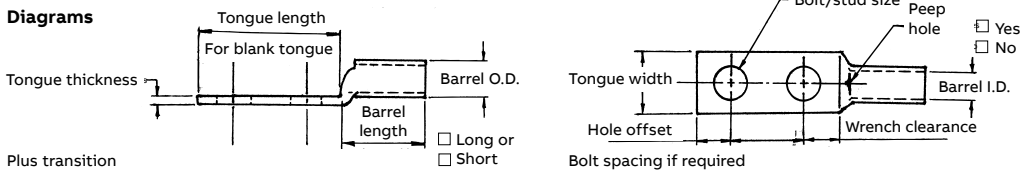

* These bolt centers not available for bolt holes larger than 1⅞".
 ** Not required for 45° and 90° top stacking.

Catalogue number selection

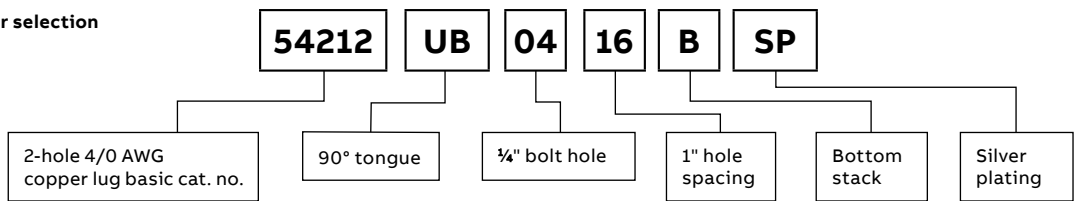

Overview

Tongue specifications (see chart “A” for dimensions)

Chart A

Stud sizes:

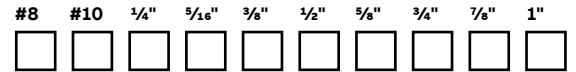

Nominal bolt hole size 0.015	Hole offset 0.030 (in.)	Wrench clearance min. (in.)	Tongue width cable size (in.)										
			#8 Code #8 Weld	#6 Code #6 Weld	#4 Code #4 Weld	#2 Code #4 Weld	#1 Code #2 Weld	1/0 Code #1 Weld	2/0 Code 1/0 Weld	3/0 Code 2/0 Weld	4/0 Code 3/0 Weld	250 Code	
#8	0.173	0.200	0.240	0.406	0.437	0.562	0.593	0.672	0.750	0.825	0.937	1.030	1.125
#10	0.204	0.218	0.250	0.406	0.437	0.562	0.593	0.672	0.750	0.825	0.937	1.030	1.125
1/4	0.281	0.250	0.312	0.469	0.500	0.562	0.593	0.672	0.750	0.825	0.937	1.030	1.125
5/16	0.344	0.375	0.406	0.562	0.562	0.562	0.675	0.672	0.750	0.825	0.937	1.030	1.125
3/8	0.406	0.375	0.440	0.578	0.578	0.594	0.675	0.672	0.750	0.825	0.937	1.030	1.125
1/2	0.531	0.500	0.562	-	-	-	0.750	0.750	0.750	0.825	0.937	1.030	1.125
5/8	0.656	0.625	0.875	-	-	-	-	-	-	-	0.937	1.030	1.125
3/4	0.812	0.750	0.770	-	-	-	-	-	-	-	-	-	-
7/8*	0.937	0.875	0.890	-	-	-	-	-	-	-	-	-	-
1*	1.062	0.937	1.000	-	-	-	-	-	-	-	-	-	-

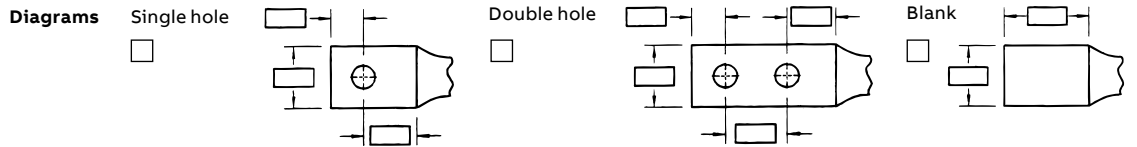

* These bolt holes available in one-hole lug only.

Chart B

Cable size (AWG or kcmil)	Tongue thickness (in.)	Straight lug barrel length plus transition (in.)		Barrel (in.)		Dim "X" Stacked lugs (in.)			Dim "Y" (in.)		Dim "H" (in.)	
		Short	Long	O.D.	I.D.	Straight	45°	90°	Short	Long	Short	Long
#8	0.080	0.635	0.935	0.260	0.180	0.158	0.478	0.394	0.595	0.808	0.779	1.079
#6	0.081	0.675	0.975	0.296	0.215	0.134	0.544	0.432	0.587	0.799	0.767	1.067
#4	0.099	0.685	0.985	0.365	0.266	0.175	0.622	0.502	0.637	0.849	0.838	1.138
#2	0.108	0.815	1.115	0.410	0.302	0.216	0.649	0.535	0.711	0.923	0.958	1.258
#1	0.106	0.825	1.275	0.467	0.361	0.212	0.731	0.592	0.710	1.028	0.956	1.406
1/0	0.125	0.975	1.325	0.520	0.396	0.250	0.789	0.646	0.794	1.042	1.075	1.425
2/0	0.125	0.965	1.315	0.571	0.446	0.250	0.859	0.696	0.829	1.077	1.125	1.475
3/0	0.125	1.085	1.435	0.632	0.507	0.250	0.946	0.757	0.900	1.148	1.225	1.575
4/0	0.137	1.255	1.705	0.701	0.564	0.274	1.031	0.826	1.015	1.333	1.387	1.837
250	0.137	1.375	1.925	0.766	0.629	0.274	1.123	0.891	1.085	1.474	1.487	2.037
300	0.153	1.900	2.675	0.850	0.660	0.459	1.226	0.975	1.180	1.726	1.924	2.679
350	0.177	2.090	2.896	0.926	0.720	0.531	1.333	1.103	1.267	1.830	2.096	2.896
400	0.173	2.460	2.980	0.960	0.757	0.519	1.370	1.085	1.551	1.913	2.484	2.984
500	0.218	2.670	3.610	1.100	0.852	0.654	1.514	1.225	1.629	2.266	2.669	3.619
600	0.244	2.900	3.490	1.200	0.926	0.732	1.630	1.325	1.762	2.147	2.897	3.497
700	0.228	2.784	-	1.255	0.997	0.684	1.662	1.375	1.780	-	3.011	-
750	0.270	3.050	3.925	1.330	1.030	0.810	1.745	1.455	1.827	2.434	3.050	3.925
800	0.266	3.213	-	1.375	1.079	0.800	1.728	1.625	1.952	2.787	3.213	4.554
900	0.313	3.450	4.550	1.500	1.145	0.940	1.900	1.650	2.065	-	1.387	-
1,000	0.297	3.356	4.500	1.550	1.203	0.890	2.070	1.675	2.031	2.787	1.487	4.506

Note: Stacking lugs are available for one bolt only. Consult factory: straight: 700 kcmil & up – 45°: 400 kcmil & up, 90°: 500 kcmil & up.

Chart C

Bolt hole size	Tongue width 0.030 code cable size (in.)										
	300 kcmil 4/0 Weld	350 kcmil	400 kcmil	500 kcmil 400 Weld	600 kcmil 500 Weld	1325/24	700 kcmil	750 kcmil	800 kcmil	900 kcmil	1,000 kcmil
#8	-	-	-	-	-	-	-	-	-	-	-
#10	-	-	-	-	-	-	-	-	-	-	-
¼	1.250	1.355	1.410	1.605	1.745	1.805	1.840	1.935	2.010	2.180	2.265
⅝	1.250	1.355	1.410	1.605	1.745	1.805	1.840	1.935	2.010	2.180	2.265
¾	1.250	1.355	1.410	1.605	1.745	1.805	1.840	1.935	2.010	2.180	2.265
½	1.250	1.355	1.410	1.605	1.745	1.805	1.840	1.935	2.010	2.180	2.265
⅝	1.250	1.355	1.410	1.605	1.745	1.805	1.840	1.935	2.010	2.180	2.265
¾	1.250	1.355	1.410	1.605	1.745	1.805	1.840	1.935	2.010	2.180	2.265
7/8*	-	-	-	1.605	1.745	1.805	1.840	1.935	2.010	2.180	2.265
1*	-	-	-	-	1.745	1.805	1.840	1.935	2.010	2.180	2.265

Diagrams

Formula 1 = (0.125 + 2 (O.D.) + 0.037 – Tongue thickness)

Straight stack

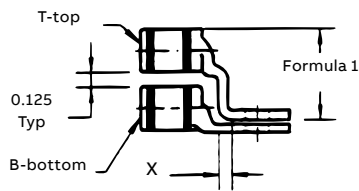

45° stack

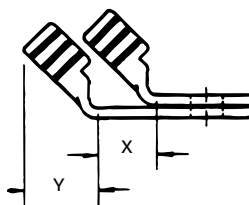

90° stack

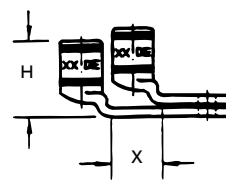

45°



90°

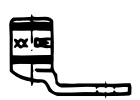

* These bolt holes available in one-hole lug only.

Compression connectors for copper conductors



Material – High-conductivity wrought copper

Finish – Electro tin plated



One-hole lugs – Standard barrel certified to 600 V and recommended up to 35 kV*

Cat no.	Code cable	Wire size			Dimensions in. (mm)						Die code	Colour code
		Flex cable classes G, H, I, K, M	Bolt size		A	B	C	D	E	F		
54101	#14–10 AWG		–	¼	1.23 (31.2)	0.56 (14.2)	0.50 (12.7)	0.05 (1.3)	0.20 (5.1)	0.25 (6.4)	ERG2002	Yellow
256-30695-1351	#14–10 AWG		#8	¼	1.36 (34.5)	0.68 (17.3)	0.36 (9.1)	0.05 (1.3)	0.20 (5.1)	0.25 (6.4)	ERG2002	
256-30695-1352	#14–10 AWG			¼	1.36 (34.5)	0.68 (17.3)	0.41 (10.4)	0.05 (1.3)	0.20 (5.1)	0.25 (6.4)	ERG2002	
256-30695-263	#14–10 AWG			¼	1.69 (43.0)	0.81 (20.6)	0.50 (12.7)	0.07 (1.8)	0.20 (5.1)	0.25 (6.4)	ERG2002	
54104	#8 AWG	#8 Str.,	#10	¼	1.16 (29.5)	0.50 (12.7)	0.39 (9.9)	0.08 (2.0)	0.25 (6.4)	0.22 (5.6)	21	Red
54130	#8 AWG	23 Navy	¼	1.20 (30.5)	0.61 (15.5)	0.45 (11.4)	0.07 (1.8)	0.25 (6.4)	0.25 (6.4)	21		
54131	#8 AWG	#8 Weld	5/16	1.33 (33.8)	0.64 (16.3)	0.56 (14.2)	0.05 (1.3)	0.25 (6.4)	0.28 (7.1)	21		
54132	#8 AWG	37/24	3/8	1.33 (33.8)	0.64 (16.3)	0.56 (14.2)	0.05 (1.3)	0.25 (6.4)	0.28 (7.1)	21		
256-30695-424	#8 AWG	0.180	½	1.75 (44.5)	1.31 (33.3)	1.00 (25.4)	0.13 (3.3)	0.25 (6.4)	0.50 (12.7)	21		
256-30695-1361	#6 AWG	#6 Str.,	#12	¼	1.23 (31.2)	0.53 (13.5)	0.44 (11.2)	0.07 (1.8)	0.31 (7.8)	0.22 (5.6)	24	Blue
54134	#6 AWG	#30 Navy	#10	¼	1.23 (31.2)	0.53 (13.5)	0.44 (11.2)	0.07 (1.8)	0.31 (7.8)	0.22 (5.6)	24	
54105	#6 AWG	#6 Weld	¼	1.23 (31.2)	0.53 (13.5)	0.44 (11.2)	0.07 (1.8)	0.31 (7.8)	0.22 (5.6)	24		
54135	#6 AWG	61/24	5/16	1.41 (35.8)	0.67 (17.0)	0.60 (15.2)	0.07 (1.8)	0.31 (7.8)	0.31 (7.9)	24		
54136	#6 AWG	133/0.014,	3/8	1.41 (35.8)	0.67 (17.0)	0.60 (15.2)	0.07 (1.8)	0.31 (7.8)	0.31 (7.9)	24		
256-30695-282	#6 AWG	0.227	3/8	1.41 (35.8)	0.75 (19.1)	0.56 (14.2)	0.06 (1.5)	0.31 (7.8)	0.31 (7.9)	24		
256-30695-422	#6 AWG		½	1.75 (44.5)	1.31 (33.3)	1.00 (25.4)	0.13 (3.3)	0.31 (7.8)	0.50 (12.7)	24		
256-30695-1362	#4 AWG	#5 Str., 40-50	#12	¼	1.38 (35.1)	0.60 (15.2)	0.55 (14.0)	0.09 (2.3)	0.37 (9.4)	0.25 (6.4)	29	Grey
54138	#4 AWG	Navy	#10	¼	1.38 (35.1)	0.60 (15.2)	0.55 (14.0)	0.09 (2.3)	0.37 (9.4)	0.25 (6.4)	29	
54106	#4 AWG	91/24	¼	1.38 (35.1)	0.60 (15.2)	0.55 (14.0)	0.09 (2.3)	0.37 (9.4)	0.25 (6.4)	29		
54139	#4 AWG	133/0.0177,	5/16	1.42 (36.1)	0.66 (16.8)	0.61 (15.5)	0.07 (1.8)	0.37 (9.4)	0.31 (7.9)	29		
54140	#4 AWG	49/0.029	3/8	1.42 (36.1)	0.66 (16.8)	0.61 (15.5)	0.07 (1.8)	0.37 (9.4)	0.31 (7.9)	29		
256-30695-233	#4 AWG	0.265	3/8	1.56 (37.0)	0.75 (19.1)	0.59 (15.0)	0.06 (1.5)	0.37 (9.4)	0.31 (7.9)	29		
256-30695-264	#4 AWG		½	2.20 (56.0)	1.40 (35.6)	1.00 (25.4)	0.06 (1.5)	0.37 (9.4)	0.50 (12.7)	29		
54107	#2 AWG	#3 Str.,	¼	1.50 (38.1)	0.65 (16.5)	0.59 (15.0)	0.11 (2.8)	0.41 (10.4)	0.25 (6.4)	33	Brown	
54142-TB	#2 AWG	#60 Navy	5/16	1.73 (43.9)	0.88 (22.4)	0.59 (15.0)	0.11 (2.8)	0.41 (10.4)	0.38 (9.7)	33		
54143-TB	#2 AWG	125/24	3/8	1.65 (41.9)	0.80 (20.3)	0.59 (15.0)	0.11 (2.8)	0.41 (10.4)	0.38 (9.7)	33		
54145-TB	#2 AWG	#4 Weld	½	1.92 (48.8)	1.08 (27.4)	0.75 (19.1)	0.08 (2.0)	0.41 (10.4)	0.50 (12.7)	33		
54108	#1 AWG	#2 Str., 75 Navy,	¼	1.50 (38.1)	0.65 (16.5)	0.68 (17.3)	0.11 (2.8)	0.47 (11.9)	0.25 (6.4)	37	Green	
54147	#1 AWG	#2 Weld	5/16	1.73 (43.9)	0.93 (23.6)	0.68 (17.3)	0.11 (2.8)	0.47 (11.9)	0.38 (9.7)	37		
54148	#1 AWG	150/24, 175/24	3/8	1.78 (45.2)	0.98 (24.9)	0.68 (17.3)	0.11 (2.8)	0.47 (11.9)	0.38 (9.7)	37		
54150	#1 AWG	133/0.0223,	½	2.10 (53.3)	1.25 (31.8)	0.76 (19.3)	0.11 (2.8)	0.47 (11.9)	0.50 (12.7)	37		

Diagrams

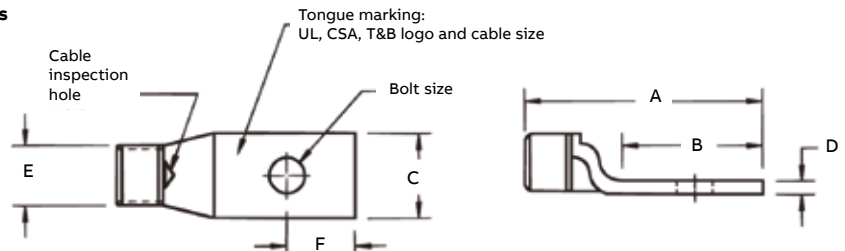

* For installations from 16 kV up to 35 kV, consult shielded cable manufacturers for stress relief and insulation requirements. Call your regional sales office for sizes not listed. For tool and die selection charts, see the section E31-E48 of the Tools, Dies and Kits catalogue.

Compression connectors for copper conductors



Material – High-conductivity wrought copper
Finish – Electro tin plated



One-hole lugs – Standard barrel certified to 600 V and recommended up to 35 kV* (continued)

Cat no.	Code cable	Wire size		Dimensions in. (mm)							Die code	Colour code
		Flex cable classes G, H, I, K, M	Bolt size	A	B	C	D	E	F			
54152-TB	1/0 AWG	1 AWG, #100 Navy #1 Weld 225/24 133/0.0254, 0.389 min.	¼	1.60 (40.6)	0.65 (16.5)	0.75 (19.1)	0.13 (3.3)	0.52 (13.2)	0.25 (6.4)	42	Pink	
54153-TB	1/0 AWG		5/16	1.83 (46.5)	0.88 (22.4)	0.75 (19.1)	0.13 (3.3)	0.52 (13.2)	0.38 (9.7)	42		
54109	1/0 AWG		¾	1.88 (47.8)	0.93 (23.6)	0.75 (19.1)	0.13 (3.3)	0.52 (13.2)	0.38 (9.7)	42		
54155-TB	1/0 AWG		½	2.20 (55.9)	1.25 (31.8)	0.75 (19.1)	0.13 (3.3)	0.52 (13.2)	0.50 (12.7)	42		
256-30695-1383	1/0 AWG		5/8	2.54 (64.5)	1.50 (38.1)	0.88 (22.4)	0.13 (3.3)	0.52 (13.2)	0.63 (16.0)	42		
54157	2/0 AWG	1/0 AWG, 125 Navy 1/0 Weld 275/24 427/0.0155, 438 min. 133/0.0282	¼	1.65 (41.9)	0.65 (16.5)	0.83 (21.1)	0.13 (3.3)	0.57 (14.5)	0.25 (6.4)	45	Black	
54158	2/0 AWG		5/16	1.88 (47.8)	0.88 (22.4)	0.83 (21.1)	0.13 (3.3)	0.57 (14.5)	0.38 (9.7)	45		
54110	2/0 AWG		¾	1.93 (49.0)	0.93 (23.6)	0.83 (21.1)	0.13 (3.3)	0.57 (14.5)	0.38 (9.7)	45		
54160	2/0 AWG		½	2.25 (57.2)	1.25 (31.6)	0.83 (21.1)	0.13 (3.3)	0.57 (14.5)	0.50 (12.7)	45		
256-30695-131	2/0 AWG		5/8	2.56 (65.0)	1.50 (38.1)	0.83 (21.1)	0.13 (3.3)	0.57 (14.5)	0.63 (16.0)	45		
54162-TB	3/0 AWG	2/0 AWG, 150 Navy 2/0 Weld, 325/24 133/0.0316, 259/0.0227 427/0.0177, 0.500	¼	1.75 (44.5)	0.65 (16.5)	0.92 (23.4)	0.13 (3.3)	0.63 (16.0)	0.25 (6.4)	50	Orange	
54163-TB	3/0 AWG		5/16	1.98 (50.3)	0.88 (22.4)	0.92 (23.4)	0.13 (3.3)	0.63 (16.0)	0.38 (9.7)	50		
54111	3/0 AWG		¾	2.03 (51.6)	0.93 (23.6)	0.92 (23.4)	0.13 (3.3)	0.63 (16.0)	0.38 (9.7)	50		
54165-TB	3/0 AWG		½	2.35 (59.7)	1.25 (31.8)	0.92 (23.4)	0.13 (3.3)	0.63 (16.0)	0.50 (12.7)	50		
54167	4/0 AWG		3/4	2.86 (72.6)	1.56 (39.6)	1.03 (26.2)	0.14 (3.6)	0.70 (17.8)	0.75 (19.1)	54		
54168	4/0 AWG	3/0 AWG, 200 Navy 3/0 Weld 450/24 703/0.0154, 0.560	¼	1.90 (48.3)	0.65 (16.5)	1.03 (26.2)	0.14 (3.6)	0.70 (17.8)	0.25 (6.4)	54	Purple	
54112	4/0 AWG		5/16	2.13 (54.1)	0.87 (22.1)	1.03 (26.2)	0.14 (3.6)	0.70 (17.8)	0.38 (9.7)	54		
54170	4/0 AWG		¾	2.18 (55.4)	0.93 (23.6)	1.03 (26.2)	0.14 (3.6)	0.70 (17.8)	0.38 (9.7)	54		
54170	4/0 AWG		½	2.50 (63.5)	1.25 (31.8)	1.03 (26.2)	0.14 (3.6)	0.70 (17.8)	0.50 (12.7)	54		
256-30695-1174	4/0 AWG		3/4	2.86 (72.6)	1.56 (39.6)	1.03 (26.2)	0.14 (3.6)	0.70 (17.8)	0.75 (19.1)	54		
58161	-	4/0 Weld 550/24 130/0.0399 259/0.0286 66	¼	2.23 (56.6)	0.78 (19.8)	1.25 (31.8)	0.15 (3.8)	0.79 (20.1)	0.38 (9.7)	62	Yellow	
58162	-		5/16	2.33 (59.2)	0.88 (22.4)	1.25 (31.8)	0.15 (3.8)	0.79 (20.1)	0.38 (9.7)	62		
58163	-		¾	2.38 (60.5)	0.93 (23.6)	1.25 (31.8)	0.15 (3.8)	0.79 (20.1)	0.38 (9.7)	62		
58165	-		½	2.76 (70.1)	1.25 (31.8)	1.25 (31.8)	0.15 (3.8)	0.79 (20.1)	0.50 (12.7)	62		
58166	-		5/8	3.03 (77.0)	1.58 (40.1)	1.25 (31.8)	0.15 (3.8)	0.79 (20.1)	0.83 (21.1)	62		
54172-TB	250 kcmil		4/0	¼	2.00 (50.8)	0.65 (16.5)	1.13 (28.7)	0.14 (3.6)	0.77 (19.6)	0.50 (12.7)		62
54173	250 kcmil	250 Navy 0.629	5/16	2.23 (56.6)	0.88 (22.4)	1.13 (28.7)	0.14 (3.6)	0.77 (19.6)	0.38 (9.7)	62		
54174	250 kcmil		¾	2.28 (57.9)	0.93 (23.6)	1.13 (28.7)	0.14 (3.6)	0.77 (19.6)	0.38 (9.7)	62		
54113	250 kcmil		½	2.60 (66.0)	1.25 (31.8)	1.13 (28.7)	0.14 (3.6)	0.77 (19.6)	0.50 (12.7)	62		

Diagrams

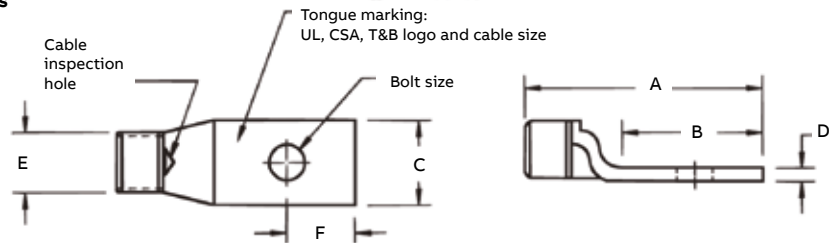

* For installations from 16 kV up to 35 kV, consult shielded cable manufacturers for stress relief and insulation requirements. Call your regional sales office for sizes not listed. For tool and die selection charts, see the section E31-E48 of the Tools, Dies and Kits catalogue.

Compression connectors for copper conductors



Material – High-conductivity wrought copper
Finish – Electro tin plated



One-hole lugs – Standard barrel certified to 600 V and recommended up to 35 kV* (continued)

Cat no.	Code cable	Wire size		Dimensions in. (mm)							Die code	Colour code
		Flex cable classes G, H, I, K, M	Bolt size	A	B	C	D	E	F			
58168	-	250 Weld 650/24 = 262 kcmil 259/0.0311, 703/0.0189	1/2	2.70 (68.6)	1.25 (31.8)	1.25 (31.8)	0.15 (3.8)	0.85 (21.6)	0.50 (12.7)	66	White	
54178	300 kcmil	250 kcmil	3/16	2.33 (59.2)	0.88 (22.4)	1.25 (31.8)	0.15 (3.8)	0.85 (21.6)	0.38 (9.7)	66		
54179		300 Navy 0.660	3/8	2.43 (61.7)	0.93 (23.6)	1.25 (31.8)	0.15 (3.8)	0.85 (21.6)	0.38 (9.7)	66		
54114			1/2	2.70 (68.6)	1.25 (31.8)	1.25 (31.8)	0.15 (3.8)	0.85 (21.6)	0.50 (12.7)	66		
54181			5/8	3.03 (77.0)	1.58 (40.1)	1.25 (31.8)	0.15 (3.8)	0.85 (21.6)	0.75 (19.1)	66		
58171	-	300 Weld, 259/0.034 427/0.0265, 889/0.0183 775/24 = 313 kcmil, 0.719	1/2	2.85 (72.4)	1.25 (31.8)	1.36 (34.5)	0.18 (4.6)	0.93 (23.6)	0.50 (12.7)	71	Red	
256-30695-112	350 kcmil	350 Navy 0.719	3/8	2.90 (73.7)	1.25 (31.8)	1.36 (34.5)	0.18 (4.6)	0.93 (23.6)	0.50 (12.7)	71		
54115	350 kcmil		1/2	2.85 (72.4)	1.25 (31.8)	1.36 (34.5)	0.18 (4.6)	0.93 (23.6)	0.50 (12.7)	71		
54183	350 kcmil		5/8	3.21 (81.5)	1.28 (32.5)	1.36 (34.5)	0.18 (4.6)	0.93 (23.6)	0.75 (19.1)	71		
58174	-	350 Weld, 259/0.0368 427/0.0285 889/0.0201	1/2	3.35 (85.1)	1.25 (31.8)	1.61 (40.9)	0.22 (5.6)	1.09 (27.7)	0.50 (12.7)	76	Blue	
54116	400 kcmil	300 kcmil, 400 Navy, 0.757	1/2	3.20 (81.3)	1.25 (31.8)	1.41 (35.8)	0.17 (4.3)	0.96 (24.4)	0.50 (12.7)	76		
54185	400 kcmil		5/8	3.53 (89.7)	1.58 (40.1)	1.41 (35.8)	0.17 (4.3)	0.96 (24.4)	0.75 (19.1)	76		
58177	-	400 Weld 925/24 = 373 kcmil	1/2	3.31 (84.1)	1.25 (31.8)	1.61 (40.9)	0.22 (5.6)	1.04 (26.4)	0.50 (12.7)	80	-	
256-30695-1403	-	259/0.0393 or 427/0.0306, 0.799	3/8	3.31 (84.1)	1.31 (33.3)	1.61 (40.9)	0.22 (5.6)	1.04 (26.4)	0.63 (16.0)	80		
256-30695-339	500 kcmil	925/24	3/8	3.10 (78.7)	1.00 (25.4)	1.61 (40.9)	0.22 (5.6)	1.10 (28.0)	0.38 (9.7)	87	Brown	
54118	500 kcmil	500 Navy 0.850	1/2	3.30 (83.8)	1.25 (31.8)	1.61 (40.9)	0.22 (5.6)	1.10 (27.9)	0.50 (12.7)	87		
54187	500 kcmil		5/8	3.63 (92.2)	1.58 (40.1)	1.61 (40.9)	0.22 (5.6)	1.10 (27.9)	0.63 (16.0)	87		
58180	-	1100/24 = 444 kcmil 500 Weld, 259/0.0417 427/0.0325, 703/0.0253	5/8	3.79 (96.3)	1.58 (40.1)	1.75 (44.5)	0.24 (6.1)	1.20 (30.5)	0.63 (16.0)	94	Green	
256-30695-1370	600 kcmil	0.956	1/2	3.65 (92.7)	1.44 (36.6)	1.75 (44.5)	0.24 (6.1)	1.20 (30.5)	0.48 (12.2)	94		
54120	600 kcmil		5/8	3.79 (96.3)	1.58 (40.1)	1.75 (44.5)	0.24 (6.1)	1.20 (30.5)	0.63 (16.0)	94		

Diagram

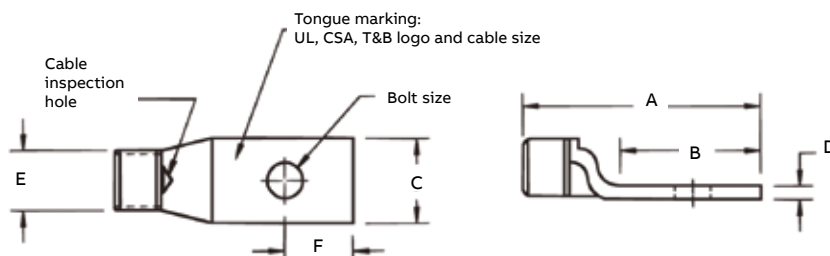

* For installations from 16 kV up to 35 kV, consult shielded cable manufacturers for stress relief and insulation requirements. Call your regional sales office for sizes not listed. For tool and die selection charts, see the section E31-E48 of the Tools, Dies and Kits catalogue.

Compression connectors for copper conductors



Material – High-conductivity wrought copper
Finish – Electro tin plated



One-hole lugs – Standard barrel certified to 600 V and recommended up to 35 kV* (continued)

Cat no.	Code cable	Wire size		Dimensions in. (mm)							Die code	Colour code
		Flex cable classes G, H, I, K, M	Bolt size	A	B	C	D	E	F			
54122-TB	700 kcmil	–	5/8	3.68 (93.5)	1.58 (40.1)	1.84 (46.7)	0.23 (5.8)	1.26 (32.0)	0.63 (16.0)	99	Pink	
256-30695-1404	–	1325/24 =	5/8	3.29 (83.6)	1.29 (32.8)	1.81 (46.0)	0.28 (7.1)	1.25 (31.8)	0.66 (16.8)	99		
256-30695-1405	–	500/535 kcmil	1/2	3.29 (83.6)	1.29 (32.8)	1.81 (46.0)	0.28 (7.1)	1.25 (31.8)	0.66 (16.8)	99		
256-30695-840	–	427/0.0342, 0.968	1/2	4.00 (101.6)	1.69 (42.9)	1.81 (46.0)	0.28 (7.1)	1.25 (31.8)	0.48 (12.2)	99		
58182	–	–	5/8	3.83 (97.3)	1.58 (40.1)	1.81 (46.0)	0.28 (7.1)	1.25 (31.8)	0.63 (16.0)	99		
256-30695-193	–	1.060	1/2	4.00 (101.6)	1.69 (42.9)	1.94 (49.3)	0.27 (6.9)	1.33 (33.8)	0.48 (12.2)	106	Black	
54123-TB	750 kcmil	1.060	5/8	3.87 (98.3)	1.58 (40.1)	1.94 (49.3)	0.27 (6.9)	1.33 (33.8)	0.63 (16.0)	106		
58184	–	1600/24 = 646 kcmil	5/8	3.80 (96.5)	1.58 (40.1)	1.94 (49.3)	0.27 (6.9)	1.33 (33.8)	0.63 (16.0)	106		
54124-TB	800 kcmil	800 Navy, 1.109	5/8	4.04 (102.6)	1.58 (40.1)	2.01 (51.1)	0.27 (6.9)	1.38 (35.1)	0.63 (16.0)	107	Orange	
256-30695-843	900 kcmil	1925/24 =	1/2	4.31 (109.5)	1.81 (46.0)	2.17 (55.1)	0.31 (7.9)	1.50 (38.1)	0.88 (22.4)	115	Yellow	
54126	900 kcmil	750/777 kcmil, 1.187	5/8	4.15 (105.4)	1.58 (40.1)	2.17 (55.1)	0.31 (7.9)	1.50 (38.1)	0.63 (16.0)	115		
54128	1,000 kcmil	1,000 Navy, 1.253	5/8	4.09 (103.9)	1.58 (40.1)	2.27 (57.7)	0.30 (7.6)	1.55 (39.4)	0.63 (16.0)	125	–	

Diagram

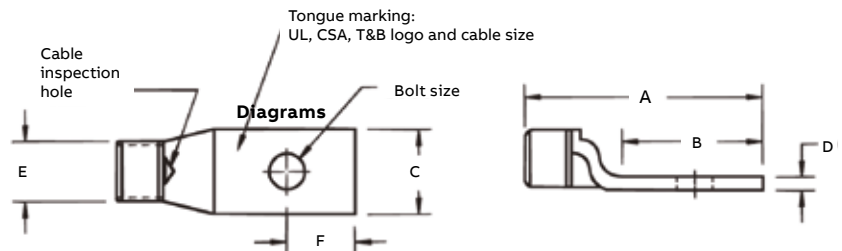

* For installations from 16 kV up to 35 kV, consult shielded cable manufacturers for stress relief and insulation requirements. Call your regional sales office for sizes not listed. For tool and die selection charts, see the section E31-E48 of the Tools, Dies and Kits catalogue.

Compression connectors for copper conductors



Material – High-conductivity wrought copper

Finish – Electro tin plated



One-hole lugs – 45° Standard barrel certified to 600 V and recommended up to 35 kV*

Cat no.	Code cable	Wire size		Dimensions in. (mm)					Die code	Colour code
		Flex cable classes G, H, I, K, M	Bolt size	B	C	D	E	F		
54104UF	#8 AWG	#8 Str., 23 Navy	#10	0.50 (12.7)	0.39 (9.9)	0.08 (2.0)	0.25 (6.4)	0.22 (5.6)	21	Red
54130UF	#8 AWG	#8 weld 37/24	¼	0.61 (15.5)	0.45 (11.4)	0.07 (1.8)	0.25 (6.4)	0.25 (6.4)	21	
54131UF	#8 AWG	0.180	⅝	0.64 (16.3)	0.56 (14.2)	0.05 (1.3)	0.25 (6.4)	0.28 (7.1)	21	
54132UF	#8 AWG		⅜	0.64 (16.3)	0.56 (14.2)	0.05 (1.3)	0.25 (6.4)	0.28 (7.1)	21	
54134UF	#6 AWG	#6 Str., 30 Navy	#10	0.53 (13.5)	0.44 (11.2)	0.07 (1.8)	0.31 (7.9)	0.22 (5.6)	24	Blue
54105UF	#6 AWG	#6 Weld 61/24	¼	0.53 (13.5)	0.44 (11.2)	0.07 (1.8)	0.31 (7.9)	0.22 (5.6)	24	
54135UF	#6 AWG	133/0.014	⅝	0.67 (17.0)	0.60 (15.2)	0.07 (1.8)	0.31 (7.9)	0.31 (7.8)	24	
54136UF	#6 AWG	0.227	⅜	0.67 (17.0)	0.60 (15.2)	0.07 (1.8)	0.31 (7.9)	0.31 (7.8)	24	
54138UF	#4 AWG	#5 Str., 40-50 Navy	#10	0.60 (15.2)	0.55 (14.0)	0.09 (2.3)	0.37 (9.4)	0.25 (6.4)	29	Grey
54106UF	#4 AWG	91/24	¼	0.60 (15.2)	0.55 (14.0)	0.09 (2.3)	0.37 (9.4)	0.25 (6.4)	29	
54139UF	#4 AWG	133/0.0177	⅝	0.66 (16.8)	0.61 (15.5)	0.07 (1.8)	0.37 (9.4)	0.31 (7.8)	29	
54140UF	#4 AWG	49/0.029	⅝	0.66 (16.8)	0.61 (15.5)	0.07 (1.8)	0.37 (9.4)	0.31 (7.8)	29	
256-30695-264UF	#4 AWG	0.265	⅜	0.66 (16.8)	0.61 (15.5)	0.07 (1.8)	0.37 (9.4)	0.31 (7.8)	29	
54107UF	#2 AWG	#3 Str.	¼	0.65 (16.5)	0.59 (15.0)	0.11 (2.8)	0.41 (10.4)	0.25 (6.4)	33	Brown
54142UF	#2 AWG	60 Navy 125/24	⅝	0.88 (22.4)	0.59 (15.0)	0.11 (2.8)	0.41 (10.4)	0.38 (9.7)	33	
54143UF	#2 AWG	#4 Weld	⅜	0.80 (20.3)	0.59 (15.0)	0.11 (2.8)	0.41 (10.4)	0.38 (9.7)	33	
54145UF	#2 AWG	0.300	½	1.08 (27.4)	0.75 (19.1)	0.08 (2.0)	0.41 (10.4)	0.50 (12.7)	33	
54108UF	#1 AWG	#2 AWG, 75 Navy, #2 Weld	¼	0.65 (16.5)	0.68 (17.3)	0.11 (2.8)	0.47 (11.9)	0.25 (6.4)	37	Green
54147UF	#1 AWG	150/24	⅝	0.93 (23.6)	0.68 (17.3)	0.11 (2.8)	0.47 (11.9)	0.38 (9.7)	37	
54148UF	#1 AWG	175/24	⅜	0.98 (24.9)	0.68 (17.3)	0.11 (2.8)	0.47 (11.9)	0.38 (9.7)	37	
54150UF	#1 AWG	133/0.0223	½	1.25 (31.8)	0.76 (19.3)	0.11 (2.8)	0.47 (11.9)	0.50 (12.7)	37	
54152UF	1/0 AWG	#1 AWG	¼	0.65 (16.5)	0.75 (19.1)	0.13 (3.3)	0.52 (13.2)	0.25 (6.4)	42	Pink
54153UF	1/0 AWG	100 Navy, #1 Weld	⅝	0.88 (22.4)	0.75 (19.1)	0.13 (3.3)	0.52 (13.2)	0.38 (9.7)	42	
54109UF	1/0 AWG	225/24	⅜	0.93 (23.6)	0.75 (19.1)	0.13 (3.3)	0.52 (13.2)	0.38 (9.7)	42	
54155UF	1/0 AWG	133/0.0254	½	1.25 (31.8)	0.75 (19.1)	0.13 (3.3)	0.52 (13.2)	0.50 (12.7)	42	
54157UF	2/0 AWG	1/0 AWG, 125 Navy	¼	0.65 (16.5)	0.83 (21.1)	0.13 (3.3)	0.57 (14.5)	0.25 (6.4)	45	Black
54158UF	2/0 AWG	1/0 Weld	⅝	0.88 (22.4)	0.83 (21.1)	0.13 (3.3)	0.57 (14.5)	0.38 (9.7)	45	
54110UF	2/0 AWG	275/24	⅜	0.93 (23.6)	0.83 (21.1)	0.13 (3.3)	0.57 (14.5)	0.38 (9.7)	45	
54160UF	2/0 AWG	427/0.0155, 133/0.0282	½	1.25 (31.8)	0.83 (21.1)	0.13 (3.3)	0.57 (14.5)	0.50 (12.7)	45	

Diagrams

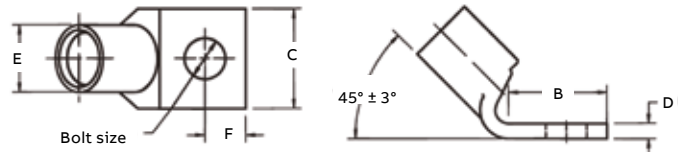

* For installations from 16 kV up to 35 kV, consult shielded cable manufacturers for stress relief and insulation requirements. Call your regional sales office for sizes not listed. For tool and die selection charts, see the section E31-E48 of the Tools, Dies and Kits catalogue.

Compression connectors for copper conductors



Material – High-conductivity wrought copper
Finish – Electro tin plated



One-hole lugs – 45° Standard barrel certified to 600 V and recommended up to 35 kV* (continued)

Cat no.	Code cable	Wire size		Dimensions in. (mm)					Die code	Colour code
		Flex cable classes G, H, I, K, M	Bolt size	B	C	D	E	F		
54162UF	3/0 AWG	2/0 AWG, 150 Navy	¼	0.65 (16.5)	0.92 (23.4)	0.13 (3.3)	0.63 (16.0)	0.25 (6.4)	50	Orange
54163UF	3/0 AWG	2/0 Weld, 325/24	⅝ ₁₆	0.88 (22.4)	0.92 (23.4)	0.13 (3.3)	0.63 (16.0)	0.38 (9.7)	50	
54111UF	3/0 AWG	133/0.0316, 259/0.0227	⅜	0.93 (23.6)	0.92 (23.4)	0.13 (3.3)	0.63 (16.0)	0.38 (9.7)	50	
54165UF	3/0 AWG	427/0.0177	½	1.25 (31.8)	0.92 (23.4)	0.13 (3.3)	0.63 (16.0)	0.50 (12.7)	50	
58147UF*	–	375/24	¼	0.78 (19.8)	1.03 (26.2)	0.16 (4.1)	0.70 (17.8)	0.34 (8.6)	50	
58148UF*	–		⅝ ₁₆	0.78 (19.8)	1.03 (26.2)	0.16 (4.1)	0.70 (17.8)	0.34 (8.6)	50	
58149UF*	–		⅜	0.81 (20.6)	1.03 (26.2)	0.16 (4.1)	0.70 (17.8)	0.38 (9.7)	50	
58151UF*	–		½	1.06 (26.9)	1.03 (26.2)	0.16 (4.1)	0.70 (17.8)	0.50 (12.7)	50	
54167UF	4/0 AWG	3/0 AWG	¼	0.65 (16.5)	1.03 (26.2)	0.14 (3.6)	0.70 (17.8)	0.25 (6.4)	54	Purple
54168UF	4/0 AWG	200 Navy, 3/0 Weld	⅝ ₁₆	0.87 (22.1)	1.03 (26.2)	0.14 (3.6)	0.70 (17.8)	0.38 (9.7)	54	
54112UF	4/0 AWG	450/24	⅜	0.93 (23.6)	1.03 (26.2)	0.14 (3.6)	0.70 (17.8)	0.38 (9.7)	54	
54170UF	4/0 AWG	703/0.0154	½	1.25 (31.8)	1.03 (26.2)	0.14 (3.6)	0.70 (17.8)	0.50 (12.7)	54	
58161UF	–	4/0 AWG, 4/0 Weld	¼	0.78 (19.8)	1.25 (31.8)	0.15 (3.8)	0.79 (20.1)	0.38 (9.7)	62	Yellow
58162UF	–	550/24	⅝ ₁₆	0.88 (22.4)	1.25 (31.8)	0.15 (3.8)	0.79 (20.1)	0.38 (9.7)	62	
58163UF	–	133/0.0399	⅜	0.93 (23.6)	1.25 (31.8)	0.15 (3.8)	0.79 (20.1)	0.38 (9.7)	62	
58165UF	–	259/0.0286	½	1.25 (31.8)	1.25 (31.8)	0.15 (3.8)	0.79 (20.1)	0.50 (12.7)	62	
58166UF	–	637/0.0183	⅝ ₁₆	1.58 (40.1)	1.25 (31.8)	0.15 (3.8)	0.79 (20.1)	0.63 (16.0)	62	
54172UF	250 kcmil	4/0 AWG	¼	0.65 (16.5)	1.13 (28.7)	0.14 (3.6)	0.77 (19.6)	0.25 (6.4)	62	
54173UF	250 kcmil	250 Navy	⅝ ₁₆	0.88 (22.4)	1.13 (28.7)	0.14 (3.6)	0.77 (19.6)	0.38 (9.7)	62	
54174UF	250 kcmil	550/24	⅜	0.93 (23.6)	1.13 (28.7)	0.14 (3.6)	0.77 (19.6)	0.38 (9.7)	62	
54113UF	250 kcmil		½	1.25 (31.8)	1.13 (28.7)	0.14 (3.6)	0.77 (19.6)	0.50 (12.7)	62	
58168UF	–	250 Weld, 650/24	½	1.25 (31.8)	1.25 (31.8)	0.15 (3.8)	0.85 (21.6)	0.50 (12.7)	66	White
		259/0.0311, 703/0.0189								
54178UF	300 kcmil	250 kcmil	⅝ ₁₆	0.88 (22.4)	1.25 (31.8)	0.15 (3.8)	0.85 (21.6)	0.38 (9.7)	66	
54179UF	300 kcmil	300 Navy	⅜	0.93 (23.6)	1.25 (31.8)	0.15 (3.8)	0.85 (21.6)	0.38 (9.7)	66	
54114UF	300 kcmil	650/24	½	1.25 (31.8)	1.25 (31.8)	0.15 (3.8)	0.85 (21.6)	0.50 (12.7)	66	
54181UF	300 kcmil		⅝ ₁₆	1.58 (40.1)	1.25 (31.8)	0.15 (3.8)	0.85 (21.6)	0.63 (16.0)	66	

Diagrams

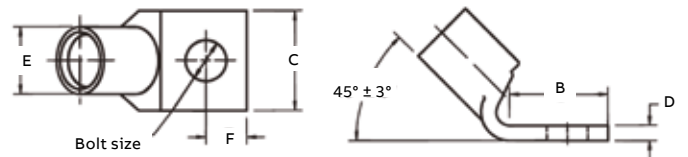

* Not CSA approved.

* For installations from 16 kV up to 35 kV, consult shielded cable manufacturers for stress relief and insulation requirements. Call your regional sales office for sizes not listed. For tool and die selection charts, see the section E31-E48 of the Tools, Dies and Kits catalogue.

Compression connectors for copper conductors



Material – High-conductivity wrought copper

Finish – Electro tin plated



One-hole lugs – 45° Standard barrel certified to 600 V and recommended up to 35 kV[†] (continued)

Cat no.	Code cable	Wire size		Dimensions in. (mm)						Die code	Colour code
		Flex cable classes G, H, I, K, M	Bolt size	B	C	D	E	F			
58171UF	–	300 kcmil, 300 Weld 259/0.034, 427/0.0265 889/0.0183 775/24 = 313 kcmil	½	1.25 (31.8)	1.36 (34.5)	0.18 (4.6)	0.93 (23.6)	0.50 (12.7)	71	Red	
256-30695-112UF	350 kcmil	650/24	¾	1.25 (31.8)	1.36 (34.5)	0.18 (4.6)	0.93 (23.6)	0.50 (12.7)	71	Red	
54115UF	350 kcmil	350 Navy 262 kcmil	½	1.25 (31.8)	1.36 (34.5)	0.18 (4.6)	0.93 (23.6)	0.50 (12.7)	71		
54183UF	350 kcmil		¾	1.58 (40.1)	1.36 (34.5)	0.18 (4.6)	0.93 (23.6)	0.63 (16.0)	71		
58174UF	–	350 Weld 259/0.0368, 427/0.0285 703/0.0224, 889/0.0201	½	1.25 (31.8)	1.61 (40.9)	0.22 (5.6)	1.09 (27.7)	0.50 (12.7)	76	Blue	
54116UF	400 kcmil	300 kcmil, 400 Navy 775/24, 313 kcmil	½	1.25 (31.8)	1.41 (35.8)	0.17 (4.3)	0.96 (24.4)	0.50 (12.7)	76	Blue	
54185UF	400 kcmil		¾	1.58 (40.1)	1.41 (35.8)	0.17 (4.3)	0.96 (24.4)	0.63 (16.0)	76		
256-30695-1403UF	–	350 kcmil, 400 Weld 925/24 = 373 kcmil	¾	1.31 (28.7)	1.61 (40.9)	0.22 (5.6)	1.04 (26.4)	0.63 (16.0)	80	–	
58177UF	–		½	1.25 (31.8)	1.61 (40.9)	0.22 (5.6)	1.04 (26.4)	0.50 (12.7)	80		
54118UF	500 kcmil	925/24	½	1.25 (31.8)	1.61 (40.9)	0.22 (5.6)	1.10 (27.9)	0.50 (12.7)	87	Brown	
58187UF	500 kcmil	500 Navy 400 kcmil	¾	1.58 (40.1)	1.61 (40.9)	0.22 (5.6)	1.10 (27.9)	0.63 (16.0)	87		
58180UF	–	1,100/24 = 444 kcmil 500 Weld, 259/0.0417 427/0.0325, 703/0.0253	¾	1.58 (40.1)	1.75 (44.5)	0.24 (6.1)	1.20 (30.5)	0.50 (12.7)	94	Green	
58120UF	600 kcmil	1,110/24 = 444 kcmil	¾	1.58 (40.1)	1.75 (44.5)	0.24 (6.1)	1.20 (30.5)	0.50 (12.7)	94		
54122UF	700 kcmil	1,325/24 = 500 kcmil	¾	1.58 (40.1)	1.84 (46.7)	0.23 (5.8)	1.26 (32.0)	0.50 (12.7)	99	Pink	
256-30695-840UF	–	1,325/24 = 535 kcmil 427/0.0342	½	1.69 (42.9)	1.81 (46.0)	0.28 (7.1)	1.25 (31.8)	0.81 (20.6)	99	Pink	
58182UF	–		¾	1.58 (40.1)	1.81 (46.0)	0.28 (7.1)	1.25 (31.8)	0.63 (16.0)	99		
54123UF	750 kcmil	1,325/24 = 535 kcmil	¾	1.58 (40.1)	1.94 (49.3)	0.27 (6.9)	1.33 (33.8)	0.63 (16.0)	106	Black	
58184UF	–	1,600/24 = 646 kcmil	¾	1.58 (40.1)	1.94 (49.3)	0.27 (6.9)	1.33 (33.8)	0.63 (16.0)	106		
54124UF	800 kcmil	800 Navy	¾	1.58 (40.1)	2.01 (51.1)	0.27 (6.9)	1.38 (35.1)	0.63 (16.0)	107	Orange	
54126UF	900 kcmil	1,925/24 = 777 kcmil	¾	1.58 (40.1)	2.17 (55.1)	0.31 (7.9)	1.50 (38.1)	0.63 (16.0)	115	Yellow	
54128UF	1,000 kcmil	1,000 Navy	¾	1.58 (40.1)	2.27 (57.7)	0.30 (7.6)	1.55 (39.4)	0.63 (16.0)	125	–	

Diagrams

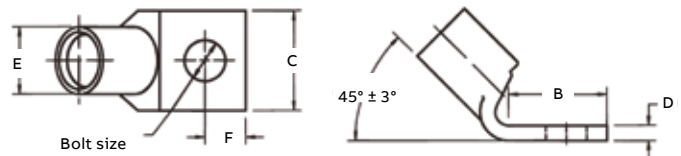

[†] For installations from 16 kV up to 35 kV, consult shielded cable manufacturers for stress relief and insulation requirements. Call your regional sales office for sizes not listed. For tool and die selection charts, see the section E31-E48 of the Tools, Dies and Kits catalogue.

Compression connectors for copper conductors



Material – High-conductivity wrought copper
Finish – Electro tin plated



One-hole lugs – 90° Standard barrel certified to 600 V and recommended up to 35 kV*

Cat no.	Code cable	Wire size		Dimensions in. (mm)						Die code	Colour code
		Flex cable classes G, H, I, K, M	Bolt size	B	C	D	E	F			
54104UB	#8 AWG	#8 Str.	#10	0.50 (12.7)	0.39 (9.9)	0.08 (2.0)	0.25 (6.4)	0.22 (5.6)	21	Red	
54130UB	#8 AWG	23 Navy	¼	0.61 (15.5)	0.45 (11.4)	0.07 (1.8)	0.25 (6.4)	0.25 (6.4)	21		
54131UB	#8 AWG	#8 Weld	⅝	0.64 (16.3)	0.56 (14.2)	0.05 (1.3)	0.25 (6.4)	0.28 (7.1)	21		
54132UB	#8 AWG	37/24	⅝	0.64 (16.3)	0.56 (14.2)	0.05 (1.3)	0.25 (6.4)	0.28 (7.1)	21		
54134UB	#6 AWG	0.180	⅜	0.64 (16.3)	0.56 (14.2)	0.05 (1.3)	0.25 (6.4)	0.28 (7.1)	21	Blue	
54105UB	#6 AWG	#6 AWG, 30 Navy	#10	0.53 (13.5)	0.44 (11.2)	0.07 (1.8)	0.31 (7.9)	0.22 (5.6)	24		
54105UB	#6 AWG	#6 Weld	¼	0.53 (13.5)	0.44 (11.2)	0.07 (1.8)	0.31 (7.9)	0.22 (5.6)	24		
54135UB	#6 AWG	61/24	⅝	0.67 (17.0)	0.60 (15.2)	0.07 (1.8)	0.31 (7.9)	0.31 (7.8)	24		
54136UB	#6 AWG	133/0.014	⅝	0.67 (17.0)	0.60 (15.2)	0.07 (1.8)	0.31 (7.9)	0.31 (7.8)	24	Grey	
54138UB	#4 AWG	0.227	⅜	0.67 (17.0)	0.60 (15.2)	0.07 (1.8)	0.31 (7.9)	0.31 (7.8)	24		
54138UB	#4 AWG	#5 AWG,	#10	0.60 (15.2)	0.55 (14.0)	0.09 (2.3)	0.37 (9.4)	0.25 (6.4)	29		
54106UB	#4 AWG	40/50 Navy	¼	0.60 (15.2)	0.55 (14.0)	0.09 (2.3)	0.37 (9.4)	0.25 (6.4)	29		
54139UB	#4 AWG	91/24	⅝	0.66 (16.8)	0.61 (15.5)	0.07 (1.8)	0.37 (9.4)	0.31 (7.8)	29	Brown	
54140UB	#4 AWG	133/0.0177	⅝	0.66 (16.8)	0.61 (15.5)	0.07 (1.8)	0.37 (9.4)	0.31 (7.8)	29		
54140UB	#4 AWG	49/0.029	⅝	0.66 (16.8)	0.61 (15.5)	0.07 (1.8)	0.37 (9.4)	0.31 (7.8)	29		
256-30695-264UB	#4 AWG	0.265	½	1.40 (35.6)	1.00 (25.4)	0.06 (1.5)	0.37 (9.4)	0.50 (12.7)	29		
54107UB	#2 AWG	#3 AWG	¼	0.65 (16.5)	0.59 (15.0)	0.11 (2.8)	0.41 (10.4)	0.25 (6.4)	33	Green	
54142UB	#2 AWG	60 Navy	⅝	0.88 (22.4)	0.59 (15.0)	0.11 (2.8)	0.41 (10.4)	0.38 (9.7)	33		
54143UB	#2 AWG	125/24	⅝	0.80 (20.3)	0.59 (15.0)	0.11 (2.8)	0.41 (10.4)	0.38 (9.7)	33		
54145UB	#2 AWG	#4 Weld	½	1.08 (27.4)	0.75 (19.1)	0.08 (2.0)	0.41 (10.4)	0.50 (12.7)	33		
54108UB	#1 AWG	0.300	½	1.08 (27.4)	0.75 (19.1)	0.08 (2.0)	0.41 (10.4)	0.50 (12.7)	33	Pink	
54108UB	#1 AWG	#2 AWG, 75 Navy, #2	¼	0.65 (16.5)	0.68 (17.3)	0.11 (2.8)	0.47 (11.9)	0.25 (6.4)	37		
54147UB	#1 AWG	Weld	⅝	0.93 (23.6)	0.68 (17.3)	0.11 (2.8)	0.47 (11.9)	0.38 (9.7)	37		
54148UB	#1 AWG	150/24	⅝	0.98 (24.9)	0.68 (17.3)	0.11 (2.8)	0.47 (11.9)	0.38 (9.7)	37		
54150UB	#1 AWG	175/24	⅝	0.98 (24.9)	0.68 (17.3)	0.11 (2.8)	0.47 (11.9)	0.38 (9.7)	37	Black	
54152UB	1/0 AWG	133/0.0223	½	1.25 (31.8)	0.76 (19.3)	0.11 (2.8)	0.47 (11.9)	0.50 (12.7)	37		
54152UB	1/0 AWG	0.360	½	1.25 (31.8)	0.76 (19.3)	0.11 (2.8)	0.47 (11.9)	0.50 (12.7)	37		
54152UB	1/0 AWG	#1 AWG	¼	0.65 (16.5)	0.75 (19.1)	0.13 (3.3)	0.52 (13.2)	0.25 (6.4)	42		
54153UB	1/0 AWG	100 Navy, #1 Weld	⅝	0.88 (22.4)	0.75 (19.1)	0.13 (3.3)	0.52 (13.2)	0.38 (9.7)	42	Orange	
54109UB	1/0 AWG	225/24	⅝	0.93 (23.6)	0.75 (19.1)	0.13 (3.3)	0.52 (13.2)	0.38 (9.7)	42		
54155UB	1/0 AWG	133/0.0254	⅝	0.93 (23.6)	0.75 (19.1)	0.13 (3.3)	0.52 (13.2)	0.38 (9.7)	42		
54155UB	1/0 AWG	0.389	½	1.25 (31.8)	0.75 (19.1)	0.13 (3.3)	0.52 (13.2)	0.50 (12.7)	42		
54157UB	2/0 AWG	1/0 AWG, 125 Navy	¼	0.65 (16.5)	0.83 (21.1)	0.13 (3.3)	0.57 (14.5)	0.25 (6.4)	45	Black	
54158UB	2/0 AWG	1/0 Weld	⅝	0.88 (22.4)	0.83 (21.1)	0.13 (3.3)	0.57 (14.5)	0.38 (9.7)	45		
54110UB	2/0 AWG	275/24	⅝	0.93 (23.6)	0.83 (21.1)	0.13 (3.3)	0.57 (14.5)	0.38 (9.7)	45		
54160UB	2/0 AWG	427/0.0155,	½	1.25 (31.8)	0.83 (21.1)	0.13 (3.3)	0.57 (14.5)	0.50 (12.7)	45		
54162UB	3/0 AWG	133/0.0282	½	1.25 (31.8)	0.83 (21.1)	0.13 (3.3)	0.57 (14.5)	0.50 (12.7)	45	Orange	
54162UB	3/0 AWG	2/0 AWG, 150 Navy,	¼	0.65 (16.5)	0.92 (23.4)	0.13 (3.3)	0.63 (16.0)	0.25 (6.4)	50		
54163UB	3/0 AWG	2/0 Weld	⅝	0.88 (22.4)	0.92 (23.4)	0.13 (3.3)	0.63 (16.0)	0.38 (9.7)	50		
54163UB	3/0 AWG	325/24	⅝	0.88 (22.4)	0.92 (23.4)	0.13 (3.3)	0.63 (16.0)	0.38 (9.7)	50		
54111UB	3/0 AWG	133/0.0316,	⅝	0.93 (23.6)	0.92 (23.4)	0.13 (3.3)	0.63 (16.0)	0.38 (9.7)	50	Orange	
54165UB	3/0 AWG	259/0.0227	⅝	0.93 (23.6)	0.92 (23.4)	0.13 (3.3)	0.63 (16.0)	0.38 (9.7)	50		
54165UB	3/0 AWG	427/0.0177	½	1.25 (31.8)	0.92 (23.4)	0.13 (3.3)	0.63 (16.0)	0.50 (12.7)	50		

Diagrams

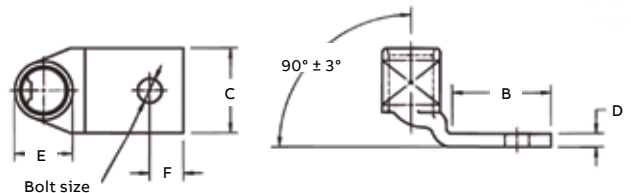

* For installations from 16 kV up to 35 kV, consult shielded cable manufacturers for stress relief and insulation requirements. Call your regional sales office for sizes not listed. For tool and die selection charts, see the section E31-E48 of the Tools, Dies and Kits catalogue.

Compression connectors for copper conductors



Material – High-conductivity wrought copper
Finish – Electro tin plated



One-hole lugs – 90° Standard barrel certified to 600 V and recommended up to 35 kV* (continued)

Cat no.	Code cable	Wire size			Dimensions in. (mm)					Die code	Colour code
		Flex cable classes G, H, I, K, M	Bolt size		B	C	D	E	F		
54167UB	–	3/0 AWG, 200 Navy,	¼		0.65 (16.5)	1.03 (26.2)	0.14 (3.6)	0.70 (17.8)	0.34 (8.6)	54	Purple
54168UB	–	3/0 Weld	5/16		0.87 (22.1)	1.03 (26.2)	0.14 (3.6)	0.70 (17.8)	0.34 (8.6)	54	
54112UB	–	450/24	¾		0.93 (23.6)	1.03 (26.2)	0.14 (3.6)	0.70 (17.8)	0.38 (9.7)	54	
54170UB	–	703/0.0154	½		1.25 (31.8)	1.03 (26.2)	0.14 (3.6)	0.70 (17.8)	0.50 (12.7)	54	
58161UB	4/0 AWG	3/0 AWG, 4/0 Weld	¼		0.78 (19.8)	1.25 (31.8)	0.15 (3.8)	0.79 (20.1)	0.38 (9.7)	62	Yellow
58162UB	4/0 AWG	550/24	5/16		0.88 (22.4)	1.25 (31.8)	0.15 (3.8)	0.79 (20.1)	0.38 (9.7)	62	
58163UB	4/0 AWG	133/0.0399	¾		0.93 (23.6)	1.25 (31.8)	0.15 (3.8)	0.79 (20.1)	0.38 (9.7)	62	
58165UB	4/0 AWG	259/0.0286	½		1.25 (31.8)	1.25 (31.8)	0.15 (3.8)	0.79 (20.1)	0.50 (12.7)	62	
58166UB	4/0 AWG	637/0.0183	5/8		1.58 (40.1)	1.25 (31.8)	0.15 (3.8)	0.79 (20.1)	0.63 (16.0)	62	
54172UB	250 kcmil	4/0 AWG	¼		0.65 (16.5)	1.13 (28.7)	0.14 (3.6)	0.77 (19.6)	0.25 (6.4)	62	
54173UB	250 kcmil	250 Navy	5/16		0.88 (22.4)	1.13 (28.7)	0.14 (3.6)	0.77 (19.6)	0.38 (9.7)	62	
54174UB	250 kcmil	550/24	¾		0.93 (23.6)	1.13 (28.7)	0.14 (3.6)	0.77 (19.6)	0.38 (9.7)	62	
54113UB	250 kcmil		½		1.25 (31.8)	1.13 (28.7)	0.14 (3.6)	0.77 (19.6)	0.50 (12.7)	62	
58168UB	–	250 Weld	½		1.25 (31.8)	1.25 (31.8)	0.15 (3.8)	0.85 (21.6)	0.50 (12.7)	66	White
		650/24 = 262 kcmil									
		259/0.0311, 703/0.0189									
54178UB	300 kcmil	250 kcmil	5/16		0.88 (22.4)	1.25 (31.8)	0.15 (3.8)	0.85 (21.6)	0.38 (9.7)	66	
54179UB	300 kcmil	300 Navy	¾		0.93 (23.6)	1.25 (31.8)	0.15 (3.8)	0.85 (21.6)	0.38 (9.7)	66	
54114UB	300 kcmil	650/24	½		1.25 (31.8)	1.25 (31.8)	0.15 (3.8)	0.85 (21.6)	0.50 (12.7)	66	
54181UB	300 kcmil		5/8		1.58 (40.1)	1.25 (31.8)	0.15 (3.8)	0.85 (21.6)	0.63 (16.0)	66	
58171UB	–	300 Weld, 259/0.034	½		1.25 (31.8)	1.36 (34.5)	0.18 (4.6)	0.93 (23.6)	0.50 (12.7)	71	
		427/0.0265, 889/0.0183									
		775/24 = 313 kcmil									
256-30695-112UB	350 kcmil	650/24, 350 Navy	¾		1.25 (31.8)	1.36 (34.5)	0.18 (4.6)	0.93 (23.6)	0.50 (12.7)	71	Red
54115UB	350 kcmil	262 kcmil	½		1.25 (31.8)	1.36 (34.5)	0.18 (4.6)	0.93 (23.6)	0.50 (12.7)	71	
54183UB	350 kcmil		5/8		1.58 (40.1)	1.36 (34.5)	0.18 (4.6)	0.93 (23.6)	0.63 (16.0)	71	
58174UB	–	350 Weld	½		1.25 (31.8)	1.61 (40.9)	0.22 (5.6)	1.09 (27.7)	0.50 (12.7)	76	Blue
		259/0.0368, 427/0.0285									
		703/0.0224, 889/0.0201									
54116UB	400 kcmil	300 kcmil, 400 Navy	½		1.25 (31.8)	1.41 (35.8)	0.17 (4.3)	0.96 (24.4)	0.50 (12.7)	76	
54185UB	400 kcmil	775/24, 313 kcmil	5/8		1.58 (40.1)	1.41 (35.8)	0.17 (4.3)	0.96 (24.4)	0.63 (16.0)	76	

Diagrams

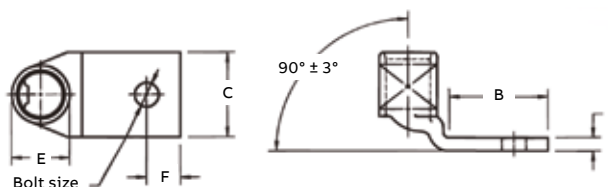

* For installations from 16 kV up to 35 kV, consult shielded cable manufacturers for stress relief and insulation requirements. Call your regional sales office for sizes not listed. For tool and die selection charts, see the section E31-E48 of the Tools, Dies and Kits catalogue.

Compression connectors for copper conductors



Material – High-conductivity wrought copper
Finish – Electro tin plated



One-hole lugs – 90° Standard barrel certified to 600 V and recommended up to 35 kV[†] (continued)

Cat no.	Code cable	Wire size			Dimensions in. (mm)					Die code	Colour code
		Flex cable classes G, H, I, K, M	Bolt size		B	C	D	E	F		
256-30695-1403UB	–	400 Weld 925/24 = 373 kcmil	5/8		1.31 (33.3)	1.61 (40.9)	0.22 (5.6)	1.04 (26.4)	0.63 (16.0)	80	–
58177UB	–	259/0.0393, 427/0.0306	1/2		1.25 (31.8)	1.61 (40.9)	0.22 (5.6)	1.04 (26.4)	0.50 (12.7)	80	
54118UB	500 kcmil	400 kcmil, 500 Navy 925/24	1/2		1.25 (31.8)	1.61 (40.9)	0.22 (5.6)	1.10 (27.9)	0.50 (12.7)	87	Brown
54187UB	500 kcmil		5/8		1.58 (40.1)	1.61 (40.9)	0.22 (5.6)	1.10 (27.9)	0.63 (16.0)	87	
58180UB	–	1,100/24 = 444 kcmil 500 Weld, 259/0.0417 427/0.0325, 703/0.0253	5/8		1.58 (40.1)	1.75 (44.5)	0.24 (6.1)	1.20 (30.5)	0.50 (12.7)	94	Green
54120UB	600 kcmil	1100/24 = 444 kcmil	5/8		1.58 (40.1)	1.75 (44.5)	0.24 (6.1)	1.20 (30.5)	0.50 (12.7)	94	
54122UB	700 kcmil	1,325/24, 535 kcmil 500 AWG, 550/535	5/8		1.58 (40.1)	1.84 (46.7)	0.23 (5.8)	1.26 (32.0)	0.50 (12.7)	99	Pink
256-30695-840UB	–	1,325/24 = 535 kcmil 427/0.0342	1/2		1.69 (42.9)	1.81 (46.0)	0.28 (7.1)	1.25 (31.8)	0.63 (16.0)	99	
58182UB	–		5/8		1.58 (40.1)	1.81 (46.0)	0.28 (7.1)	1.25 (31.8)	0.63 (16.0)	99	
54123UB	750 kcmil	–	5/8		1.58 (40.1)	1.94 (49.3)	0.27 (6.9)	1.33 (33.8)	0.63 (16.0)	106	Black
58184UB	–	1,600/24 = 646 kcmil	5/8		1.58 (40.1)	1.94 (49.3)	0.27 (6.9)	1.33 (33.8)	0.63 (16.0)	106	
54124UB	800 kcmil	800 Navy	5/8		1.58 (40.1)	2.01 (51.1)	0.27 (6.9)	1.38 (35.1)	0.63 (16.0)	107	Orange
54126UB	900 kcmil	1,925/24 = 777 kcmil	5/8		1.58 (40.1)	2.17 (55.1)	0.31 (7.9)	1.50 (38.1)	0.63 (16.0)	115	Yellow
54128UB	1,000 kcmil	1,000 Navy	5/8		1.58 (40.1)	2.27 (57.7)	0.30 (7.6)	1.55 (39.4)	0.63 (16.0)	125	–

Diagrams

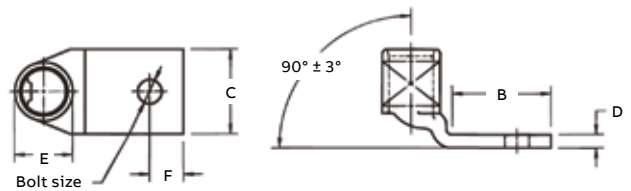

[†] For installations from 16 kV up to 35 kV, consult shielded cable manufacturers for stress relief and insulation requirements. Call your regional sales office for sizes not listed. For tool and die selection charts, see the section E31-E48 of the Tools, Dies and Kits catalogue.

Compression connectors for copper conductors



Material – High-conductivity wrought copper

Finish – Electro tin plated



Two-hole lugs – Standard barrel certified to 600 V and recommended up to 35 kV*

Cat no.	Code cable	Wire size		Dimensions in. (mm)							Die code	Colour code
		Flex cable classes G, H, I, K, M	Bolt size	A	B	C	D	E	F	G		
54201	#14–10 AWG		– ¼	1.86 (47.2)	1.19 (30.2)	0.50 (12.7)	0.05 (1.3)	0.20 (5.1)	0.25 (6.4)	0.63 (16.0)	ERG2002	Yellow
256-30695-1302	#14–10 AWG		¾	2.48 (63.0)	1.81 (46.0)	0.56 (14.2)	0.04 (1.0)	0.22 (5.6)	0.38 (9.7)	1.00 (25.4)	ERG2002	Yellow
54204	#8 AWG	#8 AWG,	#10	1.88 (47.8)	1.18 (30.0)	0.42 (10.7)	0.08 (2.0)	0.26 (6.6)	0.25 (6.4)	0.63 (16.0)	21	Red
256-31426-33*	#8 AWG	23 Navy	#10	1.88 (47.8)	1.18 (30.0)	0.41 (10.4)	0.06 (1.5)	0.26 (6.6)	0.23 (5.8)	0.75 (19.0)	21	
256-31426-33PH	#8 AWG	#8 Weld	#10	1.88 (47.8)	1.18 (30.0)	0.41 (10.4)	0.06 (1.5)	0.26 (6.6)	0.23 (5.8)	0.75 (19.0)	21	
542040410	#8 AWG	37/24	¼	2.01 (51.1)	1.31 (33.3)	0.42 (10.7)	0.08 (2.0)	0.26 (6.6)	0.25 (6.4)	0.63 (16.0)	21	
542040416	#8 AWG		¼	2.38 (60.5)	1.68 (42.7)	0.42 (10.7)	0.08 (2.0)	0.26 (6.6)	0.25 (6.4)	1.00 (25.4)	21	
256-30695-1094	#8 AWG		¼	2.50 (63.5)	1.81 (46.0)	0.56 (14.22)	0.05 (1.3)	0.26 (6.6)	0.25 (6.4)	0.75 (19.0)	21	
256-30695-251	#8 AWG		¾	2.50 (63.5)	1.81 (46.0)	0.56 (14.22)	0.05 (1.3)	0.26 (6.6)	0.38 (9.7)	1.00 (25.4)	21	
256-30695-1070	#6 AWG	#6 AWG,	#12	1.81 (46.0)	1.19 (30.2)	0.44 (11.2)	0.11 (2.8)	0.30 (7.6)	0.25 (6.4)	0.50 – 0.63 (12.7 – 16.0)	24	Blue
		30 Navy										
256-30695-1153	#6 AWG	#6 Weld	#10	1.98 (50.3)	1.28 (32.5)	0.44 (11.2)	0.08 (2.0)	0.30 (7.6)	0.25 (6.4)	0.50 (12.7)	24	
256-30695-1183	#6 AWG	61/24	#10	1.98 (50.3)	1.19 (30.2)	0.44 (11.2)	0.08 (2.0)	0.30 (7.6)	0.22 (5.6)	0.63 – 0.75 (16.0 – 19.0)	24	
		133/0.014										
54205	#6 AWG		¼	1.98 (50.3)	1.28 (32.5)	0.44 (11.2)	0.08 (2.0)	0.30 (7.6)	0.25 (6.4)	0.63 (16.0)	24	
256-30695-1095	#6 AWG		¼	2.13 (54.1)	1.31 (33.3)	0.43 (10.9)	0.08 (2.0)	0.30 (7.6)	0.25 (6.4)	0.75 (19.0)	24	
256-30695-252	#6 AWG		¼	2.38 (60.5)	1.63 (41.4)	0.43 (10.9)	0.08 (2.0)	0.30 (7.6)	0.25 (6.4)	1.00 (25.4)	24	
256-30695-372	#6 AWG		¼	2.13 (54.1)	1.43 (36.3)	0.43 (10.9)	0.08 (2.0)	0.30 (7.6)	0.25 (6.4)	0.75 (19.0)	24	
256-30695-913	#6 AWG		¼	2.38 (60.5)	1.75 (44.5)	0.43 (10.9)	0.08 (2.0)	0.30 (7.6)	0.25 (6.4)	1.00 (25.4)	24	
256-30695-253	#6 AWG		¾	2.58 (65.3)	1.81 (45.9)	0.55 (14.0)	0.08 (2.0)	0.30 (7.6)	0.38 (9.7)	1.00 (25.4)	24	
54206	#4 AWG	#5 AWG	¼	2.03 (51.6)	1.28 (32.5)	0.52 (13.2)	0.10 (2.5)	0.37 (9.4)	0.25 (6.4)	0.63 (16.0)	29	Grey
		40-50 Navy										
256-30695-1184	#4 AWG	91/24	5/16	2.31 (58.7)	1.63 (41.4)	0.52 (13.2)	0.10 (2.5)	0.37 (9.4)	0.31 (7.9)	1.00 (25.4)	29	
256-30695-255	#4 AWG	133/0.0177	¾	2.56 (65.0)	1.81 (45.9)	0.59 (15.0)	0.09 (2.3)	0.37 (9.4)	0.38 (9.7)	1.00 (25.4)	29	
		49/0.029										
54207	#2 AWG	#3 AWG	¼	2.13 (54.1)	1.28 (32.5)	0.59 (15.0)	0.11 (2.8)	0.41 (10.4)	0.25 (6.4)	0.63 (16.0)	33	Brown
		60 Navy										
256-30695-1355	#2 AWG	125/24,	¼	2.15 (54.6)	1.31 (33.3)	0.59 (15.0)	0.13 (3.3)	0.41 (10.4)	0.25 (6.4)	0.75 (19.0)	33	
256-30695-1185	#2 AWG	#4 Weld	¼	2.38 (60.5)	1.53 (38.9)	0.59 (15.0)	0.11 (2.8)	0.41 (10.4)	0.25 (6.4)	1.00 (25.4)	33	
256-30695-257	#2 AWG		¾	2.67 (67.8)	1.81 (45.9)	0.60 (15.2)	0.10 (2.5)	0.41 (10.4)	0.38 (9.7)	1.00 (25.4)	33	
256-30695-1049	#2 AWG		½	3.75 (95.3)	2.88 (73.2)	0.75 (19.1)	0.09 (2.3)	0.41 (10.4)	0.31 (7.9)	1.75 (44.5)	33	
54208	#1 AWG	#2 AWG,	¼	2.13 (54.1)	1.28 (32.5)	0.68 (17.3)	0.11 (2.8)	0.47 (11.9)	0.25 (6.4)	0.63 (16.0)	37	Green
		75 Navy										
256-30695-1233	#1 AWG	150/24	5/16	2.69 (68.3)	1.62 (41.2)	0.69 (17.5)	0.13 (3.3)	0.47 (11.9)	0.34 (8.6)	1.00 (25.4)	37	
256-30695-1236	#1 AWG	175/24	¾	2.75 (69.9)	1.81 (45.9)	0.68 (17.3)	0.11 (2.8)	0.47 (11.9)	0.38 (9.7)	1.00 (25.4)	37	
		133/0.0223										

Diagrams

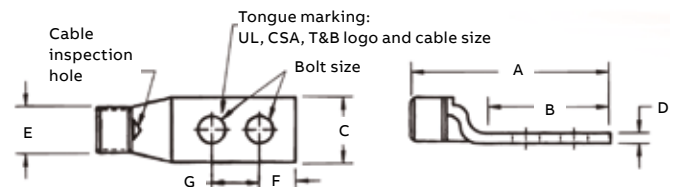

* Blind end

* For installations from 16 kV up to 35 kV, consult shielded cable manufacturers for stress relief and insulation requirements. Call your regional sales office for sizes not listed. For tool and die selection charts, see the section E31-E48 of the Tools, Dies and Kits catalogue.

Compression connectors for copper conductors



Material – High-conductivity wrought copper
Finish – Electro tin plated



Two-hole lugs – Standard barrel certified to 600 V and recommended up to 35 kV* (continued)

Cat no.	Code cable	Wire size		Dimensions in. (mm)								Die code	Colour code
		Flex cable classes G, H, I, K, M	Bolt size	A	B	C	D	E	F	G			
256-30695-329	1/0 AWG	#1 AWG	¼	2.75 (69.9)	1.81 (45.9)	0.75 (19.1)	0.14 (3.6)	0.52 (13.2)	0.38 (9.7)	0.75 (19.4)	42	Pink	
54255	1/0 AWG	100 Navy, #1 Weld	⅜	2.56 (65.0)	1.56 (39.6)	0.75 (19.1)	0.14 (3.6)	0.52 (13.2)	0.38 (9.7)	0.88 (22.4)	42		
256-30695-1234	1/0 AWG	225/24	⅜	2.75 (69.9)	1.78 (45.2)	0.75 (19.1)	0.14 (3.6)	0.52 (13.2)	0.33 (8.4)	1.00 (25.4)	42		
54209	1/0 AWG	133/0.0254	⅜	2.88 (73.2)	1.93 (49.0)	0.75 (19.1)	0.13 (3.3)	0.52 (13.2)	0.38 (9.7)	1.00 (25.4)	42		
256-30695-1265	1/0 AWG		⅜	3.50 (89.0)	2.57 (65.3)	0.75 (19.1)	0.14 (3.6)	0.52 (13.2)	0.38 (9.7)	1.75 (44.5)	42		
256-30695-886	1/0 AWG		½	3.78 (96.0)	2.83 (71.2)	0.75 (19.1)	0.13 (3.3)	0.52 (13.2)	0.5 (12.7)	1.75 (44.5)	42		
256-30695-1175	2/0 AWG	1/0 AWG,	¼	2.45 (6.2)	1.44 (36.6)	0.83 (21.1)	0.14 (3.6)	0.57 (14.5)	0.25 (6.4)	0.75 (19.0)	45	Black	
54261	2/0 AWG	125 Navy	⅜	2.70 (68.6)	1.63 (41.4)	0.83 (21.1)	0.14 (3.6)	0.57 (14.5)	0.33 (8.4)	0.88 (22.4)	45		
256-30695-832	2/0 AWG	1/0 Weld	⅜	2.88 (73.2)	1.81 (45.9)	0.81 (20.6)	0.14 (3.6)	0.57 (14.5)	0.38 (9.7)	1.00 (25.4)	45		
54210	2/0 AWG	275/24	⅜	2.93 (74.4)	1.93 (49.0)	0.83 (21.1)	0.13 (3.3)	0.57 (14.5)	0.38 (9.7)	1.00 (25.4)	45		
54260	2/0 AWG	133/0.0282	⅜	2.93 (74.4)	1.93 (49.0)	0.83 (21.1)	0.13 (3.3)	0.57 (14.5)	0.38 (9.7)	1.00 (25.4)	45		
54260	2/0 AWG		½	3.83 (97.3)	2.81 (71.4)	0.83 (21.1)	0.14 (3.6)	0.57 (14.5)	0.38 (9.7)	1.75 (44.5)	45		
54266	3/0 AWG	150 Navy, 2/0 Weld	⅜	2.88 (73.2)	1.75 (44.5)	0.94 (23.9)	0.14 (3.6)	0.63 (16.0)	0.33 (8.4)	1.00 (25.4)	50	Orange	
54211	3/0 AWG	2/0 AWG, 325/24	⅜	2.94 (74.7)	1.81 (46.0)	0.94 (23.9)	0.14 (3.6)	0.63 (16.0)	0.38 (9.7)	1.00 (25.4)	50		
54265	3/0 AWG	133/0.0316	½	3.94 (100.1)	2.81 (71.4)	0.94 (23.9)	0.14 (3.6)	0.63 (16.0)	0.50 (12.7)	1.75 (44.5)	50		
54265	3/0 AWG	259/0.0227	½	3.94 (100.1)	2.81 (71.4)	0.94 (23.9)	0.14 (3.6)	0.63 (16.0)	0.50 (12.7)	1.75 (44.5)	50		
54265	3/0 AWG	427/0.0177	½	3.94 (100.1)	2.81 (71.4)	0.94 (23.9)	0.14 (3.6)	0.63 (16.0)	0.50 (12.7)	1.75 (44.5)	50		
54212	4/0 AWG	3/0 AWG, 200 Navy	⅜	3.18 (80.8)	1.93 (49.0)	1.03 (26.2)	0.14 (3.6)	0.70 (17.8)	0.38 (9.7)	1.00 (25.4)	54	Purple	
54270	4/0 AWG	3/0 Weld	½	4.25 (108.0)	3.00 (76.2)	1.03 (26.2)	0.14 (3.6)	0.70 (17.8)	0.50 (12.7)	1.75 (44.5)	54		
256-30695-1247	4/0 AWG	450/24 = 182 kcmil	¼	3.06 (77.7)	1.44 (36.6)	1.03 (26.2)	0.16 (4.1)	0.70 (17.8)	0.38 (9.7)	0.63 (16.0)	54		
256-30695-331	4/0 AWG	703/0.0154	¼	3.06 (77.7)	1.81 (46.0)	1.03 (26.2)	0.14 (3.6)	0.70 (17.8)	0.38 (9.7)	0.75 (19.1)	54		
256-30695-1261	4/0 AWG		⅜	3.18 (80.8)	1.93 (49.0)	1.03 (26.2)	0.14 (3.6)	0.70 (17.8)	0.38 (9.7)	1.00 (25.4)	54		
54213	250 kcmil	4/0 AWG	⅜	3.28 (83.3)	1.93 (49.0)	1.13 (28.7)	0.14 (3.6)	0.77 (19.6)	0.38 (9.7)	1.00 (25.4)	62		
54275	250 kcmil	250 Navy	½	4.19 (106.4)	2.81 (71.4)	1.13 (28.7)	0.18 (4.6)	0.77 (19.6)	0.50 (12.7)	1.75 (44.5)	62	Yellow	
256-30695-345	-	4/0 AWG, 4/0 Weld	⅜	3.25 (82.6)	1.69 (42.9)	1.25 (31.8)	0.15 (3.8)	0.79 (20.1)	0.38 (9.7)	0.88 (22.4)	62		
256-30695-835	-	550/24 = 222 kcmil	⅜	4.25 (108.0)	2.80 (71.1)	1.25 (31.8)	0.15 (3.8)	0.79 (20.1)	0.38 (9.7)	1.00 (25.4)	62		
256-30695-452	-	133/0.0399	⅜	3.13 (79.5)	1.88 (47.8)	1.25 (31.8)	0.16 (4.1)	0.79 (20.1)	0.38 (9.7)	0.88 (22.4)	62		
58265	-	259/0.0286	⅜	3.13 (79.5)	1.88 (47.8)	1.25 (31.8)	0.16 (4.1)	0.79 (20.1)	0.38 (9.7)	0.88 (22.4)	62		
58265	-	637/0.018	½	3.94 (100.1)	2.81 (71.4)	0.94 (23.9)	0.14 (3.6)	0.79 (20.1)	0.50 (12.7)	1.75 (44.5)	62		
54214	300 kcmil	250 AWG, 300 Navy	⅜	3.45 (87.6)	1.93 (49.0)	1.25 (31.8)	0.15 (3.8)	0.85 (21.6)	0.38 (9.7)	1.00 (25.4)	66	White	
54280	300 kcmil	650/24 = 262 kcmil	½	4.45 (113.0)	3.00 (76.2)	1.25 (31.8)	0.15 (3.8)	0.85 (21.6)	0.50 (12.7)	1.75 (44.5)	66		
256-30695-332	350 kcmil	350 Navy	¼	3.40 (86.4)	1.81 (46.0)	1.36 (34.5)	0.18 (4.6)	0.93 (23.6)	0.38 (9.7)	0.75 (19.1)	71	Red	
256-30695-1240	350 kcmil		⅜	4.18 (106.2)	2.63 (66.8)	1.36 (34.5)	0.18 (4.6)	0.93 (23.6)	0.38 (9.7)	1.75 (44.5)	71		
54215	350 kcmil		⅜	3.51 (89.2)	1.93 (49.0)	1.36 (34.5)	0.18 (4.6)	0.93 (23.6)	0.38 (9.7)	1.00 (25.4)	71		
54282	350 kcmil		½	4.60 (116.8)	3.00 (76.2)	1.36 (34.5)	0.18 (4.6)	0.93 (23.6)	0.50 (12.7)	1.75 (44.5)	71		

Diagrams

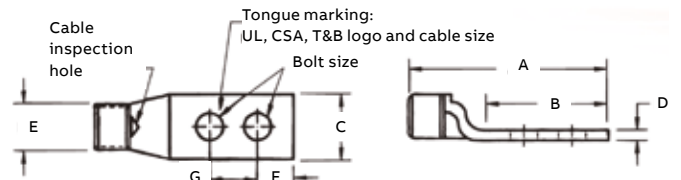

* For installations from 16 kV up to 35 kV, consult shielded cable manufacturers for stress relief and insulation requirements. Call your regional sales office for sizes not listed. For tool and die selection charts, see the section E31-E48 of the Tools, Dies and Kits catalogue.

Compression connectors for copper conductors



Material – High-conductivity wrought copper

Finish – Electro tin plated



Two-hole lugs – Standard barrel certified to 600 V and recommended up to 35 kV* (continued)

Cat no.	Code cable	Wire size		Bolt size	Dimensions in. (mm)							Die G code	Colour code
		Flex cable classes G, H, I, K, M			A	B	C	D	E	F			
54216	400 kcmil	300 kcmil, 313 kcmil	775/24	3/8	3.93 (99.8)	1.93 (49.0)	1.41 (35.8)	0.17 (4.3)	0.96 (24.4)	0.38 (9.7)	1.00 (25.4)	76	Blue
54283	400 kcmil			3/8	3.88 (98.6)	1.93 (49.0)	1.41 (35.8)	0.17 (4.3)	0.96 (24.4)	0.38 (9.7)	1.06 (26.9)	76	Blue
256-30695-439	–	400 Weld		3/8	4.35 (110.5)	2.25 (57.2)	1.61 (40.9)	0.22 (5.6)	1.04 (26.4)	0.50 (12.7)	1.00 (25.4)	80	–
58277	–	925/24 = 373 kcmil		1/2	5.06 (128.5)	3.00 (76.2)	1.61 (40.9)	0.22 (5.6)	1.04 (26.4)	0.50 (12.7)	1.75 (44.5)	80	–
256-30695-839	–	259/0.0393		3/8	4.09 (103.9)	2.06 (52.3)	1.61 (40.9)	0.22 (5.6)	1.04 (26.4)	0.50 (12.7)	1.00 (25.4)	80	–
256-30695-839	–	427/0.0306		3/8	4.09 (103.9)	2.06 (52.3)	1.61 (40.9)	0.22 (5.6)	1.04 (26.4)	0.50 (12.7)	1.00 (25.4)	80	–
54218	500 kcmil	400 kcmil		3/8	3.96 (100.6)	1.93 (49.0)	1.61 (40.9)	0.22 (5.6)	1.10 (27.9)	0.38 (9.7)	1.00 (25.4)	87	Brown
54286	500 kcmil	500 Navy		1/2	5.07 (128.8)	3.00 (76.2)	1.61 (40.9)	0.22 (5.6)	1.10 (27.9)	0.50 (12.7)	1.75 (44.5)	87	Brown
256-30695-188	500 kcmil			1/2	4.06 (103.1)	2.31 (58.7)	1.63 (41.4)	0.22 (5.6)	1.10 (27.9)	0.50 (12.7)	1.25 (31.8)	87	Brown
54220	600 kcmil	–		3/8	4.13 (104.9)	1.93 (49.0)	1.75 (44.5)	0.24 (6.1)	1.20 (30.5)	0.38 (9.7)	1.00 (25.4)	94	Green
54289	600 kcmil	–		1/2	5.23 (132.8)	3.00 (76.2)	1.75 (44.5)	0.24 (6.1)	1.20 (30.5)	0.50 (12.7)	1.75 (44.5)	94	Green
256-30695-1406	700 kcmil	550/535		3/8	4.05 (102.9)	2.11 (53.6)	1.78 (45.2)	0.24 (6.1)	1.25 (31.8)	0.50 (12.7)	1.00 (25.4)	99	Pink
256-30695-842	700 kcmil	1,325/24		3/8	4.30 (109.2)	2.06 (52.3)	1.80 (45.7)	0.28 (7.1)	1.25 (31.8)	0.50 (12.7)	1.00 (25.4)	99	Pink
256-30695-898	700 kcmil	500 AWG		3/8	4.30 (109.2)	2.06 (52.3)	1.80 (45.7)	0.28 (7.1)	1.25 (31.8)	0.50 (12.7)	1.00 (25.4)	99	Pink
54291	700 kcmil	–		1/2	5.18 (131.6)	3.00 (76.2)	1.84 (46.7)	0.23 (5.8)	1.25 (31.8)	0.50 (12.7)	1.75 (44.5)	99	Pink
58281	700 kcmil	1,325/24 = 535 kcmil		1/2	5.23 (132.8)	3.00 (76.2)	1.80 (45.7)	0.28 (7.1)	1.25 (31.8)	0.50 (12.7)	1.75 (44.5)	99	Pink
256-30695-237	750 kcmil	–		3/8	5.10 (129.5)	2.80 (71.1)	1.94 (49.3)	0.27 (6.9)	1.33 (33.8)	0.38 (9.7)	1.00 (25.4)	106	Black
54223	750 kcmil	–		1/2	5.32 (135.1)	3.00 (76.2)	1.94 (49.3)	0.27 (6.9)	1.33 (33.8)	0.50 (12.7)	1.75 (44.5)	106	Black
256-30695-1376	800 kcmil	–		3/8	4.78 (121.4)	2.28 (57.9)	2.01 (51.1)	0.27 (6.9)	1.38 (35.1)	0.44 (11.2)	1.13 (28.7)	107	Orange
54224	800 kcmil	–		1/2	5.50 (139.7)	3.00 (76.2)	2.01 (51.1)	0.27 (6.9)	1.38 (35.1)	0.50 (12.7)	1.75 (44.5)	107	Orange
256-30695-694	900 kcmil	1,925/24 =		3/8	4.65 (118.1)	2.06 (52.3)	2.18 (55.4)	0.31 (7.9)	1.50 (38.1)	0.50 (12.7)	1.00 (25.4)	115	Yellow
54226	900 kcmil	777 kcmil		1/2	5.59 (142.0)	3.00 (76.2)	2.18 (55.4)	0.31 (7.9)	1.50 (38.1)	0.50 (12.7)	1.75 (44.5)	115	Yellow
256-30695-846	900 kcmil	–		3/8	4.60 (116.8)	2.06 (52.3)	2.12 (53.9)	0.31 (7.9)	1.50 (38.1)	0.50 (12.7)	1.00 (25.4)	115	Yellow
256-30695-844	900 kcmil	–		3/8	5.00 (127.0)	2.63 (66.8)	2.18 (55.4)	0.31 (7.9)	1.50 (38.1)	0.56 (14.2)	1.50 (38.1)	115	Yellow
54228	1,000 kcmil	1,000 Navy		1/2	5.45 (138.4)	3.00 (76.2)	2.27 (57.7)	0.30 (7.6)	1.55 (39.4)	0.50 (12.7)	1.75 (44.5)	125	–

Diagrams

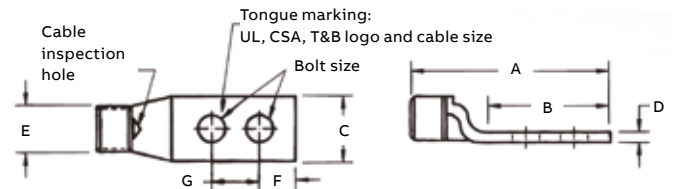

* For installations from 16 kV up to 35 kV, consult shielded cable manufacturers for stress relief and insulation requirements. Call your regional sales office for sizes not listed. For tool and die selection charts, see the section E31-E48 of the Tools, Dies and Kits catalogue.

Compression connectors for copper conductors



Material – High-conductivity wrought copper
Finish – Electro tin plated



Two-hole lugs – 45° Standard barrel certified to 600 V and recommended up to 35 kV*

Cat no.	Code cable	Wire size		Dimensions in. (mm)							Die code	Colour code
		Flex cable classes G, H, I, K, M	Bolt size	B	C	D	E	F	G			
256-31426-9	#14–10 AWG	–	#10	1.22 (31.0)	0.37 (9.4)	0.05 (1.3)	0.20 (5.1)	0.25 (6.4)	0.63 (16.0)	–	–	
54204UF	#8 AWG	#8 AWG, 23 Navy #8 Weld, 37/24	#10	1.18 (30.0)	0.42 (10.7)	0.08 (2.0)	0.26 (6.6)	0.25 (6.4)	0.63 (16.0)	21	Red	
256-30695-1183UF	#6 AWG	#6 AWG, 30 Navy #6 Weld	#10	1.19 (30.2)	0.44 (11.2)	0.08 (2.0)	0.30 (7.6)	0.22 (5.6)	0.63 – 0.75 (16.0) – (19.1)	24	Blue	
54205UF	#6 AWG	61/24 133/0.014	¼	1.28 (32.5)	0.44 (11.2)	0.08 (2.0)	0.30 (7.6)	0.25 (6.4)	0.63 (16.0)	24	Blue	
54205UF0416	#6 AWG		¼	1.56 (39.6)	0.43 (10.9)	0.08 (2.0)	0.30 (7.6)	0.25 (6.4)	1.00 (25.4)	24	Blue	
54206UF	#4 AWG	#5 AWG 40-50 Navy, 91/24 133/0.0177 49/0.029	¼	1.28 (32.5)	0.52 (13.2)	0.10 (2.5)	0.37 (9.4)	0.25 (6.4)	0.63 (16.0)	29	Grey	
54207UF	#2 AWG	#3 AWG 60 Navy, #4 Weld 125/24	¼	1.28 (32.5)	0.59 (15.0)	0.11 (2.8)	0.41 (10.4)	0.25 (6.4)	0.63 (16.0)	33	Brown	
256-30695-257UF	#2 AWG		¾	1.81 (46.0)	0.60 (15.2)	0.11 (2.8)	0.41 (10.4)	0.38 (9.7)	1.00 (25.4)	33	Brown	
54208UF	#1 AWG	#2 AWG, 75 Navy 150/24, 175/24 133/0.0223	¼	1.28 (32.5)	0.68 (17.3)	0.11 (2.8)	0.47 (11.9)	0.25 (6.4)	0.63 (16.0)	37	Green	
54209UF	1/0 AWG	#1 AWG 100 Navy, #1 Weld	¾	1.93 (49.0)	0.75 (19.1)	0.13 (3.3)	0.52 (13.2)	0.38 (9.7)	1.00 (25.4)	42	Pink	
54209UF0412	1/0 AWG	225/24 133/0.0254	¼	1.55 (39.4)	0.75 (19.1)	0.13 (3.3)	0.52 (13.2)	0.25 (6.4)	0.75 (19.1)	42	Pink	
54261UF	2/0 AWG	1/0 AWG, 125 Navy 1/0 Weld 275/24	⅝	1.63 (41.4)	0.83 (21.1)	0.14 (3.6)	0.57 (14.5)	0.33 (8.4)	0.88 (22.4)	45	Black	
54210UF	2/0 AWG		¾	1.93 (49.0)	0.83 (21.1)	0.13 (3.3)	0.57 (14.5)	0.38 (9.7)	1.00 (25.4)	45	Black	
54260UF	2/0 AWG	133/0.0282	½	2.81 (71.4)	0.83 (21.1)	0.14 (3.6)	0.57 (14.5)	0.38 (9.7)	1.75 (44.5)	45	Black	
54266UF	3/0 AWG	2/0 AWG, 150 Navy 2/0 Weld, 325/24	⅝	1.75 (44.5)	0.94 (23.9)	0.14 (3.6)	0.63 (16.0)	0.33 (8.4)	1.00 (25.4)	50	Orange	
54211UF	3/0 AWG	133/0.0316	¾	1.81 (46.0)	0.94 (23.9)	0.14 (3.6)	0.63 (16.0)	0.38 (9.7)	1.00 (25.4)	50	Orange	
54265UF	3/0 AWG	259/0.0227 427/0.0177	½	2.81 (71.4)	0.94 (23.9)	0.14 (3.6)	0.63 (16.0)	0.25 (6.4)	1.75 (44.5)	50	Orange	
54212UF	4/0 AWG	200 Navy, 3/0 AWG 3/0 Weld	¾	1.93 (49.0)	1.03 (26.2)	0.14 (3.6)	0.70 (17.8)	0.38 (9.7)	1.00 (25.4)	54	Purple	
54270UF	4/0 AWG	450/24, 703/0.0154	½	3.00 (76.2)	1.03 (26.2)	0.14 (3.6)	0.70 (17.8)	0.25 (6.4)	1.75 (44.5)	54	Purple	

Diagrams

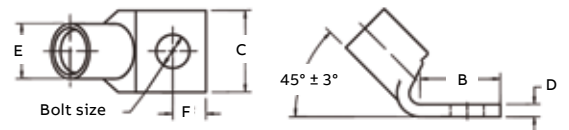

* For installations from 16 kV up to 35 kV, consult shielded cable manufacturers for stress relief and insulation requirements. Call your regional sales office for sizes not listed. For tool and die selection charts, see the section E31-E48 of the Tools, Dies and Kits catalogue.

Compression connectors for copper conductors



Material – High-conductivity wrought copper

Finish – Electro tin plated



Two-hole lugs – 45° Standard barrel certified to 600 V and recommended up to 35 kV* (continued)

Cat no.	Code cable	Wire size			Dimensions in. (mm)						Die code	Colour code
		Flex cable classes G, H, I, K, M	Bolt size		B	C	D	E	F	G		
54213UF	250 kcmil	4/0 AWG, 250 Navy	3/8	1.93 (49.0)	1.13 (28.7)	0.14 (3.6)	0.77 (19.6)	0.38 (9.7)	1.00 (25.4)	62	Yellow	
54275UF	250 kcmil	550/24	1/2	2.81 (71.4)	1.13 (28.7)	0.18 (4.6)	0.77 (19.6)	0.25 (6.4)	1.75 (44.5)	62		
256-30695-399UF	–	4/0 Weld, 550/24	3/8	2.80 (71.1)	1.25 (31.2)	0.15 (3.8)	0.79 (20.1)	0.38 (9.7)	1.00 (25.4)	62		
58265UF	–	133/0.0399 259/0.0286 637/0.018	1/2	2.81 (71.4)	0.94 (23.9)	0.14 (3.6)	0.79 (20.1)	0.25 (6.4)	1.75 (44.5)	62		
54214UF	300 kcmil	250 AWG, 300 Navy	3/8	1.93 (49.0)	1.25 (31.8)	0.15 (3.8)	0.85 (21.6)	0.38 (9.7)	1.00 (25.4)	66	White	
54280UF	300 kcmil	650/24 = 262 kcmil	1/2	3.00 (76.2)	1.25 (31.8)	0.15 (3.8)	0.85 (21.6)	0.50 (12.7)	1.75 (44.5)	66		
54215UF	350 kcmil	350 Navy	3/8	1.93 (49.0)	1.36 (34.5)	0.18 (4.6)	0.93 (23.6)	0.38 (9.7)	1.00 (25.4)	71	Red	
54282UF	350 kcmil	650/24 = 262 kcmil	1/2	3.00 (76.2)	1.36 (34.5)	0.18 (4.6)	0.93 (23.6)	0.50 (12.7)	1.75 (44.5)	71		
54216UF	400 kcmil	300 kcmil, 713 kcmil	3/8	1.93 (49.0)	1.41 (35.8)	0.17 (4.3)	0.96 (24.4)	0.38 (9.7)	1.06 (26.9)	76	Blue	
54283UF	400 kcmil	775/24	3/8	1.93 (49.0)	1.41 (35.8)	0.17 (4.3)	0.96 (24.4)	0.38 (9.7)	1.75 (44.5)	76		
54277UF	–	400 Weld	1/2	3.00 (76.2)	1.61 (40.9)	0.22 (5.6)	1.04 (26.4)	0.50 (12.7)	1.00 (25.4)	80	–	
		925/24 = 373 kcmil 259/0.0393 427/0.0306										
54218UF	500 kcmil	400 kcmil, 500 Navy	3/8	1.93 (49.0)	1.61 (40.9)	0.22 (5.6)	1.10 (27.9)	0.38 (9.7)	1.75 (44.5)	87	Brown	
54286UF	500 kcmil	925/24 = 373 kcmil	1/2	3.00 (76.2)	1.61 (40.9)	0.22 (5.6)	1.10 (27.9)	0.50 (12.7)	1.00 (25.4)	87		
54220UF	600 kcmil	1,100/24 = 444 kcmil	3/8	1.93 (49.0)	1.75 (44.5)	0.24 (6.1)	1.20 (30.5)	0.38 (9.7)	1.75 (44.5)	94	Green	
54289UF	600 kcmil		1/2	3.00 (76.2)	1.75 (44.5)	0.24 (6.1)	1.20 (30.5)	0.50 (12.7)	1.75 (44.5)	94		
54291UF	700 kcmil	500 AWG	1/2	3.00 (76.2)	1.84 (46.7)	0.23 (5.8)	1.25 (31.8)	0.50 (12.7)	1.75 (44.5)	99	Pink	
54281UF	700 kcmil	1,325/24 = 535 kcmil	1/2	3.00 (76.2)	1.84 (46.7)	0.28 (7.1)	1.25 (31.8)	0.50 (12.7)	1.75 (44.5)	99		
256-30695-237UF	750 kcmil	–	3/8	2.80 (71.1)	1.94 (49.3)	0.27 (6.9)	1.33 (33.8)	0.38 (9.7)	1.00 (25.4)	106	Black	
54223UF	750 kcmil		1/2	3.00 (76.2)	1.94 (49.3)	0.27 (6.9)	1.33 (33.8)	0.50 (12.7)	1.75 (44.5)	106		
54224UF	800 kcmil	–	1/2	3.00 (76.2)	2.01 (51.1)	0.27 (6.9)	1.38 (35.1)	0.50 (12.7)	1.75 (44.5)	106		
54226UF	900 kcmil	1,925/24 = 777 kcmil	1/2	3.00 (76.2)	2.18 (55.4)	0.31 (7.9)	1.50 (38.1)	0.50 (12.7)	1.75 (44.5)	115	Yellow	
54228UF	1,000 kcmil	1,000 Navy	1/2	3.00 (76.2)	2.27 (57.7)	0.30 (7.6)	1.55 (39.4)	0.50 (12.7)	1.75 (44.5)	125	–	

Diagrams

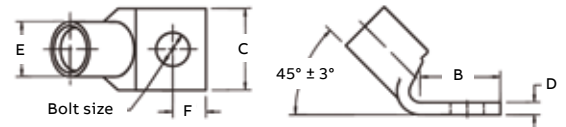

* For installations from 16 kV up to 35 kV, consult shielded cable manufacturers for stress relief and insulation requirements. Call your regional sales office for sizes not listed. For tool and die selection charts, see the section E31-E48 of the Tools, Dies and Kits catalogue.

Compression connectors for copper conductors



Material – High-conductivity wrought copper
Finish – Electro tin plated



Two-hole lugs – 90° Standard barrel certified to 600 V and recommended up to 35 kV*

Cat no.	Code cable	Wire size		Dimensions in. (mm)						Die code	Colour code
		Flex cable classes G, H, I, K, M	Bolt size	B	C	D	E	F	G		
256-31426-141	#14-10 AWG	-	#10	1.25 (31.2)	0.37 (9.4)	0.07 (1.8)	0.20 (5.1)	0.22 (5.6)	0.63 (16.0)	ERG2002	Yellow
256-31426-6SPH	#14-10 AWG		#10	1.30 (33.0)	0.37 (9.4)	0.07 (1.8)	0.20 (5.1)	0.22 (5.6)	0.63 – 0.75 (16.0) – (19.1)	ERG2002	
256-31426-6	#14-10 AWG		#10	1.30 (33.0)	0.37 (9.4)	0.07 (1.8)	0.20 (5.1)	0.22 (5.6)	0.63 (16.0)	ERG2002	
256-31426-6S	#14-10 AWG		#10	1.30 (33.0)	0.37 (9.4)	0.07 (1.8)	0.20 (5.1)	0.22 (5.6)	0.63 – 0.75 (16.0) – (19.1)	ERG2002	
256-30695-1409	#8 AWG	#8 AWG 23 Navy	#10	1.19 (30.2)	0.41 (10.4)	0.06 (1.5)	0.26 (6.6)	0.23 (5.8)	0.63 – 0.75 (16.0) – (19.1)	21	Red
54204UB	#8 AWG	#8 Weld 37/24	#10	1.25 (31.8)	0.42 (10.7)	0.08 (2.0)	0.26 (6.6)	0.25 (6.4)	0.63 (16.0)	21	
256-31426-33UB*	#8 AWG		#10	1.19 (30.2)	0.41 (10.4)	0.06 (1.5)	0.26 (6.6)	0.23 (5.8)	0.63 (16.0)	21	
256-31426-33UBPH	#8 AWG		#10	1.19 (30.2)	0.41 (10.4)	0.06 (1.5)	0.26 (6.6)	0.23 (5.8)	0.63 – 0.75 (16.0) – (19.1)	21	
256-30695-1411	#6 AWG	#6 AWG 30 Navy	#10	1.19 (30.2)	0.44 (11.2)	0.08 (2.0)	0.30 (7.6)	0.23 (5.8)	0.63 – 0.75 (16.0) – (19.1)	24	Blue
256-30695-1183B	#6 AWG	#6 Weld 133/0.014 61/24	#10	1.19 (30.2)	0.44 (11.2)	0.08 (2.0)	0.30 (7.6)	0.23 (5.8)	0.63 – 0.75 (16.0) – (19.1)	24	
256-30695-1356	#6 AWG		#10	1.19 (30.2)	0.43 (10.1)	0.08 (2.0)	0.30 (7.6)	0.23 (5.8)	0.63 (16.0)	24	
54205UB	#6 AWG		¼	1.28 (32.5)	0.44 (11.2)	0.08 (2.0)	0.30 (7.6)	0.25 (6.4)	0.63 (16.0)	24	
256-30695-252UB	#6 AWG		¼	1.56 (39.6)	0.43 (10.1)	0.08 (2.0)	0.30 (7.6)	0.25 (6.4)	1.00 (25.4)	24	Grey
54206UB	#4 AWG	#5 AWG 40-50 Navy, 91/24 133/0.0177 49/0.029	¼	1.28 (32.5)	0.52 (13.2)	0.10 (2.5)	0.37 (9.4)	0.25 (6.4)	0.63 (16.0)	29	
54207UB	#2 AWG	#3 AWG, 60 Navy Weld, 125/24	¼	1.28 (32.5)	0.59 (15.0)	0.11 (2.8)	0.41 (10.4)	0.25 (6.4)	0.63 (16.0)	33	
54208UB	#1 AWG	#2 AWG, 75 Navy 150/24, 133/0.0223	¼	1.28 (32.5)	0.68 (17.3)	0.11 (2.8)	0.47 (11.9)	0.25 (6.4)	0.63 (16.0)	37	
54209UB	1/0 AWG	1 AWG, 100 Navy, #1 Weld, 225/24	¾	1.93 (49.0)	0.75 (19.1)	0.13 (3.3)	0.52 (13.2)	0.38 (9.7)	1.00 (25.4)	42	Pink
54209UB0412	1/0 AWG	133/0.0254	¼	1.55 (39.4)	0.75 (19.1)	0.13 (3.3)	0.52 (13.2)	0.25 (6.4)	0.75 (19.1)	42	
54261UB	2/0 AWG	1/0 AWG, 125 Navy 1/0 Weld, 275/24	½	1.63 (41.4)	0.83 (21.1)	0.14 (3.6)	0.57 (14.5)	0.34 (8.6)	0.88 (22.4)	45	Black
54210UB	2/0 AWG	133/0.0282	¾	1.93 (49.0)	0.83 (21.1)	0.13 (3.3)	0.57 (14.5)	0.38 (9.7)	1.00 (25.4)	45	
54260UB	2/0 AWG		½	2.81 (71.4)	0.83 (21.1)	0.14 (3.6)	0.57 (14.5)	0.38 (9.7)	1.75 (44.5)	45	

Diagrams

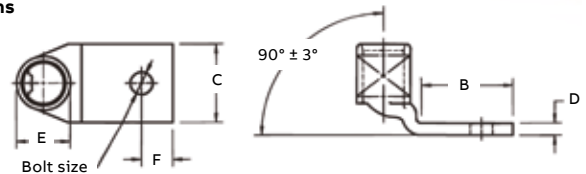

* Blind end

* For installations from 16 kV up to 35 kV, consult shielded cable manufacturers for stress relief and insulation requirements. Call your regional sales office for sizes not listed. For tool and die selection charts, see the section E31-E48 of the Tools, Dies and Kits catalogue.

Compression connectors for copper conductors



Material – High-conductivity wrought copper

Finish – Electro tin plated



Two-hole lugs – 90° Standard barrel certified to 600 V and recommended up to 35 kV[†] (continued)

Cat no.	Code cable	Wire size			Dimensions in. (mm)						Die code	Colour code
		Flex cable classes G, H, I, K, M	Bolt size		B	C	D	E	F	G		
54266UB	3/0 AWG	2/0 AWG, 150 Navy	5/16	1.75 (44.5)	0.94 (23.9)	0.14 (3.6)	0.63 (16.0)	0.34 (8.6)	1.00 (25.4)	50	Orange	
54211UB	3/0 AWG	2/0 Weld, 325/24	3/8	1.81 (46.0)	0.94 (23.9)	0.14 (3.6)	0.63 (16.0)	0.38 (9.7)	1.00 (25.4)	50		
54265UB	3/0 AWG	133/0.0316 259/0.0227 427/0.0177	1/2	2.81 (71.4)	0.94 (23.9)	0.14 (3.6)	0.63 (16.0)	0.38 (9.7)	1.75 (44.5)	50		
54212UB	4/0 AWG	3/0 AWG, 200 Navy	3/8	1.93 (49.0)	1.03 (26.2)	0.14 (3.6)	0.70 (17.8)	0.38 (9.7)	1.00 (25.4)	54	Purple	
54270UB	4/0 AWG	3/0 Weld, 450/24 703/0.0154	1/2	3.00 (76.2)	1.03 (26.2)	0.14 (3.6)	0.70 (17.8)	0.50 (12.7)	1.75 (44.5)	54		
54213UB	250 kcmil	4/0 AWG, 250 Navy	3/8	1.93 (49.0)	1.13 (28.7)	0.14 (3.6)	0.77 (19.6)	0.38 (9.7)	1.00 (25.4)	62	Yellow	
54275UB	250 kcmil	550/24	1/2	2.81 (71.4)	1.13 (28.7)	0.18 (4.6)	0.77 (19.6)	0.50 (12.7)	1.75 (44.5)	62		
256-30595-399UB	-	4/0 AWG, 4/0 Weld	3/8	2.80 (71.1)	1.25 (31.8)	0.15 (3.8)	0.79 (20.1)	0.38 (9.7)	1.00 (25.4)	62		
58265UB	-	550/24 133/0.0399 259/0.0286 637/0.018	1/2	2.81 (71.4)	0.94 (23.9)	0.14 (3.6)	0.79 (20.1)	0.50 (12.7)	1.75 (44.5)	62		
54214UB	300 kcmil	250 AWG, 300 Navy	3/8	1.93 (49.0)	1.25 (31.8)	0.15 (3.8)	0.85 (21.6)	0.38 (9.7)	1.00 (25.4)	66	White	
54280UB	300 kcmil	650/24 = 262 kcmil	1/2	3.00 (76.2)	1.25 (31.8)	0.15 (3.8)	0.85 (21.6)	0.50 (12.7)	1.75 (44.5)	66		
54215UB	350 kcmil	350 Navy	3/8	1.93 (49.0)	1.36 (34.5)	0.18 (4.6)	0.93 (23.6)	0.38 (9.7)	1.00 (25.4)	71	Red	
54282UB	350 kcmil	650/24 = 262 kcmil	1/2	3.00 (76.2)	1.36 (34.5)	0.18 (4.6)	0.93 (23.6)	0.50 (12.7)	1.75 (44.5)	71		
54216UB	400 kcmil	300/313 kcmil	3/8	1.93 (49.0)	1.41 (35.8)	0.17 (4.3)	0.96 (24.4)	0.38 (9.7)	1.06 (26.9)	76	Blue	
54283UB	400 kcmil	775/24	3/8	1.93 (49.0)	1.41 (35.8)	0.17 (4.3)	0.96 (24.4)	0.38 (9.7)	1.75 (44.5)	76		
54277UB	-	400 Weld, 925/24 373 kcmil 259/0.0393 427/0.0306	1/2	3.00 (76.2)	1.61 (40.9)	0.22 (5.6)	1.04 (26.4)	0.50 (12.7)	1.00 (25.4)	80	-	
54218UB	500 kcmil	400 kcmil	3/8	1.93 (49.0)	1.61 (40.9)	0.22 (5.6)	1.10 (27.9)	0.38 (9.7)	1.75 (44.5)	87	Brown	
54286UB	500 kcmil	500 Navy	1/2	3.00 (76.2)	1.61 (40.9)	0.22 (5.6)	1.10 (27.9)	0.50 (12.7)	1.75 (44.5)	87		
256-30695-1221B	500 kcmil	925/24 = 373 kcmil	3/8		1.61 (40.9)	0.22 (5.6)	1.10 (27.9)	0.38 (9.7)	1.00 (25.4)	87		
54220UB	600 kcmil	1,100/24, 444 kcmil	3/8	1.93 (49.0)	1.75 (44.5)	0.24 (6.1)	1.20 (30.5)	0.38 (9.7)	1.75 (44.5)	94	Green	
54289UB	600 kcmil		1/2	3.00 (76.2)	1.75 (44.5)	0.24 (6.1)	1.20 (30.5)	0.50 (12.7)	1.75 (44.5)	94		
54291UB	700 kcmil	1,325/24, 535 kcmil	1/2	3.00 (76.2)	1.84 (46.7)	0.23 (5.8)	1.25 (31.8)	0.50 (12.7)	1.75 (44.5)	99	Pink	
54281UB	700 kcmil		1/2	3.00 (76.2)	1.84 (46.7)	0.28 (7.1)	1.25 (31.8)	0.50 (12.7)	1.75 (44.5)	99		
54223UB	750 kcmil	-	1/2	3.00 (76.2)	1.94 (49.3)	0.27 (6.9)	1.33 (33.8)	0.50 (12.7)	1.75 (44.5)	106	Black	
54224UB	800 kcmil		1/2	3.00 (76.2)	2.01 (51.1)	0.27 (6.9)	1.38 (35.1)	0.50 (12.7)	1.75 (44.5)	106		
54226UB	900 kcmil	1,925/24, 777 kcmil	1/2	3.00 (76.2)	2.18 (55.4)	0.31 (7.9)	1.50 (38.1)	0.50 (12.7)	1.75 (44.5)	115	Yellow	
54228UB	1,000 kcmil	1,000 Navy	1/2	3.00 (76.2)	2.27 (57.7)	0.30 (7.6)	1.55 (39.4)	0.50 (12.7)	1.75 (44.5)	125		

Diagrams

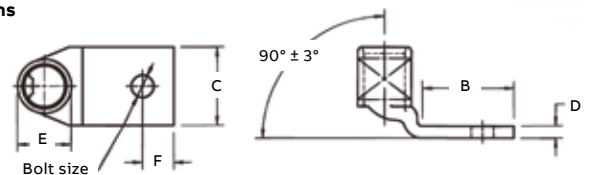

[†] For installations from 16 kV up to 35 kV, consult shielded cable manufacturers for stress relief and insulation requirements. Call your regional sales office for sizes not listed. For tool and die selection charts, see the section E31-E48 of the Tools, Dies and Kits catalogue.

Compression connectors for copper conductors



Peep holes available – Add suffix PH

Material – High-conductivity wrought copper

Finish – Electro tin plated



One-hole lugs – Long barrel certified to 600 V and recommended up to 35 kV*

Cat no.	Code cable	Wire size		Dimensions in. (mm)							Die code	Colour code
		Flex cable classes G, H, I, K, M	Bolt size	A	B	C	D	E	F			
54901BE	#14–10 AWG	–	¼	1.23 (31.2)	0.56 (14.2)	0.50 (12.7)	0.05 (1.3)	0.20 (5.1)	0.25 (6.4)	ERG2002	–	
54929BE	#8 AWG	#8 AWG	#10	1.65 (41.9)	0.65 (16.5)	0.42 (10.7)	0.08 (2.0)	0.26 (6.6)	0.25 (6.4)	21	Red	
54930BE	#8 AWG	37/24	¼	1.65 (41.9)	0.65 (16.5)	0.42 (10.7)	0.08 (2.0)	0.26 (6.6)	0.25 (6.4)	21	Red	
54904BE	#6 AWG	#6 AWG	#10	1.65 (41.9)	0.65 (16.5)	0.44 (11.2)	0.08 (2.0)	0.30 (7.6)	0.25 (6.4)	24	Blue	
54905BE	#6 AWG	61/24	¼	1.65 (41.9)	0.65 (16.5)	0.44 (11.2)	0.08 (2.0)	0.30 (7.6)	0.25 (6.4)	24	Blue	
54908BE	#4 AWG	#5 AWG	#10	1.70 (43.2)	0.65 (16.5)	0.52 (13.2)	0.10 (2.5)	0.37 (9.4)	0.25 (6.4)	29	Grey	
54906BE	#4 AWG	91/24	¼	1.70 (43.2)	0.65 (16.5)	0.52 (13.2)	0.10 (2.5)	0.37 (9.4)	0.25 (6.4)	29	Grey	
54933BE	#2–3 AWG	#3 AWG	#10	1.88 (47.8)	0.65 (16.5)	0.59 (15.0)	0.11 (2.8)	0.41 (10.4)	0.25 (6.4)	33	Brown	
54942BE	#2–3 AWG	125/24	5/16	2.03 (51.6)	0.88 (22.4)	0.59 (15.0)	0.11 (2.8)	0.41 (10.4)	0.38 (9.7)	33	Brown	
54945BE	#1 AWG	#2 AWG	#10	1.95 (49.5)	0.65 (16.5)	0.68 (17.3)	0.11 (2.8)	0.47 (11.9)	0.25 (6.4)	37	Green	
54947BE	#1 AWG	150/24	5/16	2.18 (55.4)	0.88 (22.4)	0.68 (17.3)	0.11 (2.8)	0.47 (11.9)	0.38 (9.7)	37	Green	
54946BE	1/0 AWG	#1 AWG	#10	1.95 (49.5)	0.65 (16.5)	0.75 (19.1)	0.13 (3.3)	0.52 (13.2)	0.25 (6.4)	42	Pink	
54949BE	1/0 AWG	225/24	5/16	2.18 (55.4)	0.88 (22.4)	0.75 (19.1)	0.13 (3.3)	0.52 (13.2)	0.38 (9.7)	42	Pink	
54909BE	1/0 AWG		3/8	2.23 (56.6)	0.93 (23.6)	0.75 (19.1)	0.13 (3.3)	0.52 (13.2)	0.38 (9.7)	42	Pink	
54950BE	1/0 AWG		½	2.55 (64.8)	1.25 (31.8)	0.75 (19.1)	0.13 (3.3)	0.52 (13.2)	0.50 (12.7)	42	Pink	
54910BE	2/0 AWG	1/0 AWG	3/8	2.28 (57.9)	1.25 (31.8)	0.83 (21.1)	0.13 (3.3)	0.57 (14.5)	0.38 (9.7)	45	Black	
54951BE	2/0 AWG	275/24	½	2.60 (66.4)	1.25 (31.8)	0.83 (21.1)	0.13 (3.3)	0.57 (14.5)	0.50 (12.7)	45	Black	
54965BE	3/0 AWG	2/0 AWG, 325/24	½	2.70 (68.6)	1.25 (31.8)	0.92 (23.4)	0.13 (3.3)	0.63 (16.0)	0.50 (12.7)	50	Orange	
256-30695-1252	4/0 AWG	3/0 AWG, 3/0 Weld	¼	2.35 (59.7)	0.65 (16.5)	1.03 (33.0)	0.14 (3.6)	0.70 (17.8)	0.75 (19.1)	54	Purple	
256-30695-1253	4/0 AWG	450/24	3/8	2.95 (74.9)	1.25 (31.8)	1.03 (33.0)	0.14 (3.6)	0.70 (17.8)	0.38 (9.7)	54	Purple	
54970BE	4/0 AWG		½	2.95 (74.9)	1.25 (31.8)	1.03 (33.0)	0.14 (3.6)	0.77 (19.6)	0.50 (12.7)	54	Purple	
54913BE	250 kcmil	4/0 AWG, 4/0 Weld	½	3.15 (80.1)	1.25 (31.8)	1.13 (28.7)	0.14 (3.6)	0.85 (21.6)	0.50 (12.7)	62	Yellow	
		550/24										
54914BE	300 kcmil	250 kcmil	½	3.50 (88.9)	1.25 (31.8)	1.25 (31.8)	0.15 (3.8)	0.93 (23.6)	0.50 (12.7)	66	White	
		650/24 = 262 kcmil										
54915BE	350 kcmil	–	½	3.68 (93.5)	1.58 (40.1)	1.36 (34.5)	0.18 (4.6)	0.96 (24.4)	0.50 (12.7)	71	Red	
54916BE	400 kcmil	775/24 =	½	3.75 (95.3)	1.25 (31.8)	1.41 (35.8)	0.17 (4.3)	0.96 (24.4)	0.50 (12.7)	76	Blue	
54917BE	400 kcmil	300/313 kcmil	5/8	4.03 (102.4)	1.58 (40.1)	1.41 (35.8)	0.17 (4.3)	1.10 (27.9)	0.63 (16.0)	76	Blue	
54918BE	500 kcmil	400 kcmil	½	4.25 (108.0)	1.25 (31.8)	1.61 (40.9)	0.22 (5.6)	1.10 (27.9)	0.50 (12.7)	87	Brown	
54919BE	500 kcmil	925/24 = 373 kcmil	5/8	4.57 (116.8)	1.58 (40.1)	1.61 (40.9)	0.22 (5.6)	1.20 (30.5)	0.63 (16.0)	87	Brown	
54921BE	600 kcmil	1,100/24 =	½	4.10 (104.1)	1.25 (31.8)	1.75 (44.5)	0.24 (6.1)	1.20 (30.5)	0.50 (12.7)	94	Green	
54920BE	600 kcmil	444 kcmil	5/8	4.39 (111.6)	1.58 (40.1)	1.75 (44.5)	0.24 (6.1)	1.20 (30.5)	0.63 (16.0)	94	Green	
54979BE	–	1,325/24 =	½	4.40 (111.8)	1.25 (31.8)	1.80 (45.7)	0.24 (6.1)	1.25 (31.8)	0.50 (12.7)	99	Pink	
		535 kcmil										

Diagrams

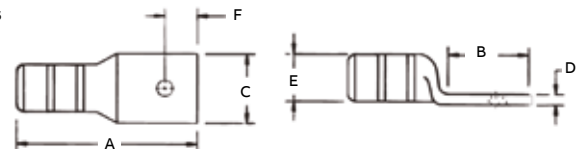

* For installations from 16 kV up to 35 kV, consult shielded cable manufacturers for stress relief and insulation requirements. Call your regional sales office for sizes not listed. For tool and die selection charts, see the section E31-E48 of the Tools, Dies and Kits catalogue.

Compression connectors for copper conductors



Peep holes available – Add suffix PH

Material – High-conductivity wrought copper

Finish – Electro tin plated



One-hole lugs – Long barrel certified to 600 V and recommended up to 35 kV[†] (continued)

Cat no.	Code cable	Wire size		Dimensions in. (mm)						Die code	Colour code
		Flex cable classes G, H, I, K, M	Bolt size	A	B	C	D	E	F		
54922BE	750 kcmil	1,325/24 = 535 kcmil	½	4.40 (111.8)	1.25 (31.8)	1.94 (49.3)	0.27 (6.9)	1.33 (33.8)	0.50 (12.7)	106	Black
54923BE	–	1,325/24 = 535 kcmil	5/8	4.72 (119.9)	1.58 (40.1)	1.94 (49.3)	0.27 (6.9)	1.33 (33.8)	0.63 (16.0)	106	Black
58984BE	–	1,600/24 = 646 kcmil	5/8	4.73 (120.1)	1.58 (40.1)	1.94 (49.3)	0.27 (6.9)	1.33 (33.8)	0.63 (16.0)	106	Black
58926BE	900 kcmil	1,925/24 = 777 kcmil	5/8	5.23 (132.8)	1.58 (40.1)	2.17 (55.1)	0.31 (7.9)	1.50 (38.1)	0.63 (16.0)	115	Yellow
54928BE	1,000 kcmil	–	5/8	5.24 (134.0)	1.58 (40.1)	2.27 (57.7)	0.30 (7.6)	1.55 (39.4)	0.63 (16.0)	125	–
256-30695-918	1,000 kcmil	–	7/8	5.42 (137.7)	1.82 (46.2)	2.38 (60.5)	0.30 (7.6)	1.55 (39.4)	0.88 (22.4)	125	–

Diagrams

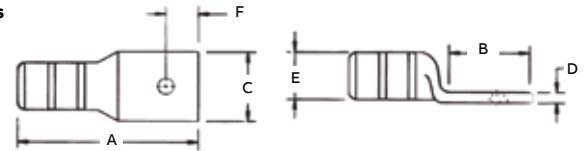

[†] For installations from 16 kV up to 35 kV, consult shielded cable manufacturers for stress relief and insulation requirements. Call your regional sales office for sizes not listed. For tool and die selection charts, see the section E31-E48 of the Tools, Dies and Kits catalogue.

Compression connectors for copper conductors



Peep holes available – Add suffix PH

Material – High-conductivity wrought copper

Finish – Electro tin plated



One-hole lugs – 45° Long barrel certified to 600 V and recommended up to 35 kV*

Cat no.	Code cable	Wire size			Dimensions in. (mm)					Die code	Colour code
		Flex cable classes G, H, I, K, M	Bolt size		B	C	D	E	F		
54929BEUF	#8 AWG	37/24	#1/0		0.65 (16.5)	0.42 (10.7)	0.08 (2.0)	0.26 (6.6)	0.25 (6.4)	21	Red
54930BEUF	#8 AWG	37/24	¼		0.65 (16.5)	0.42 (10.7)	0.08 (2.0)	0.26 (6.6)	0.25 (6.4)	21	
54904BEUF	#6 AWG	#6 AWG, 61/24	#1/0		0.65 (16.5)	0.44 (11.2)	0.08 (2.0)	0.30 (7.6)	0.25 (6.4)	24	Blue
54905BEUF	#6 AWG	#6 AWG, 61/24	¼		0.65 (16.5)	0.44 (11.2)	0.08 (2.0)	0.30 (7.6)	0.25 (6.4)	24	
54908BEUF	#4 AWG	#5 AWG, 91/24	#1/0		0.65 (16.5)	0.52 (13.2)	0.10 (2.5)	0.37 (9.4)	0.25 (6.4)	29	Grey
54906BEUF	#4 AWG	#5 AWG, 91/24	¼		0.65 (16.5)	0.52 (13.2)	0.10 (2.5)	0.37 (9.4)	0.25 (6.4)	29	
54933BEUF	#2–3 AWG	125/24	#1/0		0.65 (16.5)	0.59 (15.0)	0.11 (2.8)	0.41 (10.4)	0.25 (6.4)	33	Brown
54942BEUF	#2–3 AWG	125/24	5/16		0.88 (22.4)	0.59 (15.0)	0.11 (2.8)	0.41 (10.4)	0.88 (22.4)	33	
54945BEUF	#1 AWG	#2 AWG, 150/24 – 175/24	#1/0		0.65 (16.5)	0.68 (17.3)	0.11 (2.8)	0.47 (11.9)	0.25 (6.4)	37	Green
54947BEUF	#1 AWG	#2 AWG, 150/24 – 175/24	5/16		0.88 (22.4)	0.68 (17.3)	0.11 (2.8)	0.47 (11.9)	0.38 (9.7)	37	
54946BEUF	1/0 AWG	#1 AWG, 225/24	#1/0		0.65 (16.5)	0.75 (19.1)	0.13 (3.3)	0.52 (13.2)	0.25 (6.4)	42	Pink
54949BEUF	1/0 AWG	#1 AWG, 225/24	5/16		0.88 (22.4)	0.75 (19.1)	0.13 (3.3)	0.52 (13.2)	0.38 (9.7)	42	
54909BEUF	1/0 AWG	#1 AWG, 225/24	¾		0.93 (23.6)	0.75 (19.1)	0.13 (3.3)	0.52 (13.2)	0.38 (9.7)	42	
54950BEUF	1/0 AWG	#1 AWG, 225/24	½		1.25 (31.8)	0.75 (19.1)	0.13 (3.3)	0.52 (13.2)	0.50 (12.7)	42	
54910BEUF	2/0 AWG	1/0 AWG, 275/24	¾		0.93 (23.6)	0.83 (21.1)	0.13 (3.3)	0.57 (14.5)	0.38 (9.7)	45	Black
54951BEUF	2/0 AWG	1/0 AWG, 275/24	½		1.25 (31.8)	0.83 (21.1)	0.13 (3.3)	0.57 (14.5)	0.50 (12.7)	45	
54965BEUF	3/0 AWG	2/0 AWG – 325/24	½		1.25 (31.8)	0.92 (23.4)	0.13 (3.3)	0.63 (16.0)	0.50 (12.7)	50	Orange
54970BEUF04	4/0 AWG	3/0 AWG, 450/24, 3/0 Weld	¼		1.00 (25.4)	1.03 (26.1)	0.14 (3.6)	0.70 (17.8)	0.25 (6.4)	54	Purple
54970BEUF06	4/0 AWG	3/0 AWG, 450/24, 3/0 Weld	¾		1.13 (23.6)	1.03 (26.1)	0.14 (3.6)	0.70 (17.8)	0.38 (9.7)	54	
54970BEUF	4/0 AWG	3/0 AWG, 450/24, 3/0 Weld	½		1.25 (31.8)	1.03 (26.1)	0.14 (3.6)	0.70 (17.8)	0.50 (12.7)	54	
54913BEUF	250 kcmil	550/24 – 4/0 AWG, 4/0 Weld	½		1.25 (31.8)	1.13 (28.7)	0.14 (3.6)	0.77 (19.6)	0.50 (12.7)	62	Yellow
54914BEUF	300 kcmil	250 kcmil, 650/24 = 262 kcmil	½		1.25 (31.8)	1.25 (31.8)	0.15 (3.8)	0.85 (21.6)	0.50 (12.7)	66	White
54915BEUF	350 kcmil	650/24, 262 kcmil	½		1.25 (31.8)	1.36 (34.8)	0.18 (4.6)	0.93 (23.6)	0.50 (12.7)	71	Red
54916BEUF	400 kcmil	775/24, 300/313 kcmil	½		1.25 (31.8)	1.41 (35.8)	0.17 (4.3)	0.96 (24.4)	0.50 (12.7)	76	Blue
54917BEUF	400 kcmil	775/24, 300/313 kcmil	¾		1.58 (40.1)	1.41 (35.8)	0.17 (4.3)	0.96 (24.4)	0.63 (16.0)	76	
54918BEUF	500 kcmil	925/24, 350/373 kcmil 400 kcmil	½		1.25 (31.8)	1.61 (40.9)	0.22 (5.6)	1.10 (27.9)	0.50 (12.7)	87	Brown
54919BEUF	500 kcmil	925/24, 350/373 kcmil 400 kcmil	¾		1.58 (40.1)	1.61 (40.9)	0.22 (5.6)	1.10 (27.9)	0.63 (16.0)	87	
54921BEUF	600 kcmil	1,100/24, 444 kcmil	½		1.25 (31.8)	1.75 (44.5)	0.24 (6.1)	1.20 (30.5)	0.50 (12.7)	94	Green
54920BEUF	600 kcmil	1,100/24, 444 kcmil	¾		1.58 (40.1)	1.75 (44.5)	0.24 (6.1)	1.20 (30.5)	0.63 (16.0)	94	
54922BEUF	750 kcmil	1,325/24, 500/535 kcmil	½		1.25 (31.8)	1.94 (49.3)	0.27 (6.9)	1.33 (33.8)	0.50 (12.7)	106	Black
54923BEUF	750 kcmil	1,325/24, 500/535 kcmil	¾		1.58 (40.1)	1.94 (49.3)	0.27 (6.9)	1.33 (33.8)	0.63 (16.0)	106	
58984BEUF	–	1,600/24, 646 kcmil	¾		1.58 (40.1)	1.94 (49.3)	0.27 (6.9)	1.33 (33.8)	0.63 (16.0)	106	
58926BEUF	900 kcmil	1,925/24, 777 kcmil	¾		1.58 (40.1)	2.17 (55.1)	0.31 (7.9)	1.50 (38.1)	0.63 (16.0)	115	Yellow
54928BEUF	1,000 kcmil	–	¾		1.58 (40.1)	2.27 (57.7)	0.30 (7.6)	1.55 (39.4)	0.63 (16.0)	125	–
54928BEUF12	1,000 kcmil	–	¾		1.83 (46.5)	2.37 (60.2)	0.30 (7.6)	1.55 (39.4)	0.88 (22.4)	125	

Diagrams

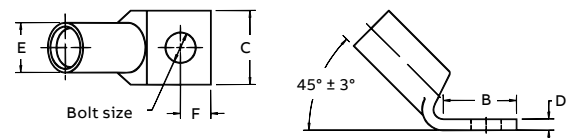

* For installations from 16 kV up to 35 kV, consult shielded cable manufacturers for stress relief and insulation requirements. Call your regional sales office for sizes not listed. For tool and die selection charts, see the section E31-E48 of the Tools, Dies and Kits catalogue.

Compression connectors for copper conductors



Peep holes available – Add suffix PH

Material – High-conductivity wrought copper

Finish – Electro tin plated



One-hole lugs – 90° Long barrel certified to 600 V and recommended up to 35 kV*

Cat no.	Code cable	Wire size			Dimensions in. (mm)					Die code	Colour code
		Flex cable classes G, H, I, K, M	Bolt size		B	C	D	E	F		
54929BEUB	#8 AWG	37/24	#10		0.65 (16.5)	0.42 (10.7)	0.08 (2.0)	0.26 (6.6)	0.25 (6.4)	21	Red
54930BEUB	#8 AWG	37/24	¼		0.65 (16.5)	0.42 (10.7)	0.08 (2.0)	0.26 (6.6)	0.25 (6.4)	21	Red
54904BEUB	#6 AWG	#6 AWG, 61/24	#10		0.65 (16.5)	0.44 (11.2)	0.08 (2.0)	0.30 (7.6)	0.25 (6.4)	24	Blue
54905BEUB	#6 AWG	#6 AWG, 61/24	¼		0.65 (16.5)	0.44 (11.2)	0.08 (2.0)	0.30 (7.6)	0.25 (6.4)	24	Blue
54908BEUB	#4 AWG	#5 AWG, 91/24	#10		0.65 (16.5)	0.52 (13.2)	0.10 (2.5)	0.37 (9.4)	0.25 (6.4)	29	Grey
54906BEUB	#4 AWG	#5 AWG, 91/24	¼		0.65 (16.5)	0.52 (13.2)	0.10 (2.5)	0.37 (9.4)	0.25 (6.4)	29	Grey
54933BEUB	#2–3 AWG	125/24	#10		0.65 (16.5)	0.59 (15.0)	0.11 (2.8)	0.41 (10.4)	0.25 (6.4)	33	Brown
54942BEUB	#2–3 AWG	125/24	⅜		0.88 (22.4)	0.59 (15.0)	0.11 (2.8)	0.41 (10.4)	0.38 (9.7)	33	Brown
54945BEUB	#1 AWG	#2 AWG, 150/24 – 175/24	#10		0.65 (16.5)	0.68 (17.3)	0.11 (2.8)	0.47 (11.9)	0.25 (6.4)	37	Green
54947BEUB	#1 AWG	#2 AWG, 150/24 – 175/24	⅜		0.88 (22.4)	0.68 (17.3)	0.11 (2.8)	0.47 (11.9)	0.38 (9.7)	37	Green
54946BEUB	1/0 AWG	#1 AWG, 225/24	#10		0.65 (16.5)	0.75 (19.1)	0.13 (3.3)	0.52 (13.2)	0.25 (6.4)	42	Pink
54949BEUB	1/0 AWG	#1 AWG, 225/24	⅜		0.88 (22.4)	0.75 (19.1)	0.13 (3.3)	0.52 (13.2)	0.38 (9.7)	42	Pink
54909BEUB	1/0 AWG	#1 AWG, 225/24	⅜		0.93 (23.6)	0.75 (19.1)	0.13 (3.3)	0.52 (13.2)	0.38 (9.7)	42	Pink
54950BEUB	1/0 AWG	#1 AWG, 225/24	½		1.25 (31.8)	0.75 (19.1)	0.13 (3.3)	0.52 (13.2)	0.50 (12.7)	42	Pink
54910BEUB	2/0 AWG	1/0 AWG, 275/24	⅜		0.93 (23.6)	0.83 (21.1)	0.13 (3.3)	0.57 (14.5)	0.38 (9.7)	45	Black
54951BEUB	2/0 AWG	1/0 AWG, 275/24	½		1.25 (31.8)	0.83 (21.1)	0.13 (3.3)	0.57 (14.5)	0.50 (12.7)	45	Black
54965BEUB	3/0 AWG	2/0 AWG – 325/24	½		1.25 (31.8)	0.92 (23.4)	0.13 (3.3)	0.63 (16.0)	0.50 (12.7)	50	Orange
54970BEUB04	4/0 AWG	3/0 AWG, 450/24, 3/0 Weld	¼		1.00 (25.4)	1.03 (26.2)	0.14 (3.6)	0.70 (17.8)	0.25 (6.4)	54	Purple
54970BEUB06	4/0 AWG	3/0 AWG, 450/24, 3/0 Weld	⅜		1.13 (28.7)	1.03 (26.2)	0.14 (3.6)	0.70 (17.8)	0.38 (9.7)	54	Purple
54970BEUB	4/0 AWG	3/0 AWG, 450/24, 3/0 Weld	½		1.25 (31.8)	1.03 (26.2)	0.14 (3.6)	0.70 (17.8)	0.50 (12.7)	54	Purple
54913BEUB	250 kcmil	550/24 – 4/0 AWG, 4/0 Weld	½		1.25 (31.8)	1.13 (28.7)	0.14 (3.6)	0.77 (19.6)	0.50 (12.7)	62	Yellow
54914BEUB	300 kcmil	250 kcmil, 650/24 = 262 kcmil	½		1.25 (31.8)	1.25 (31.8)	0.15 (3.8)	0.85 (21.6)	0.50 (12.7)	66	White
54915BEUB	350 kcmil	650/24, 262 kcmil	½		1.25 (31.8)	1.36 (34.5)	0.18 (4.6)	0.93 (23.6)	0.50 (12.7)	71	Red
54916BEUB	400 kcmil	775/24, 300/313 kcmil	½		1.58 (40.1)	1.41 (35.8)	0.17 (4.3)	0.96 (24.4)	0.50 (12.7)	76	Blue
54917BEUB	400 kcmil	775/24, 300/313 kcmil	⅝		1.25 (31.8)	1.41 (35.8)	0.17 (4.3)	0.96 (24.4)	0.63 (16.0)	76	Blue
54918BEUB	500 kcmil	925/24, 350/373 kcmil, 400 kcmil	½		1.58 (40.1)	1.61 (40.9)	0.22 (5.6)	1.10 (27.9)	0.50 (12.7)	87	Brown
54919BEUB	500 kcmil	925/24, 350/373 kcmil, 400 kcmil	⅝		1.25 (31.8)	1.61 (40.9)	0.22 (5.6)	1.10 (27.9)	0.63 (16.0)	87	Brown
54921BEUB	600 kcmil	1100/24, 444 kcmil	½		1.58 (40.1)	1.75 (44.5)	0.24 (6.1)	1.20 (30.5)	0.50 (12.7)	94	Green
54920BEUB	600 kcmil	1100/24, 444 kcmil	⅝		1.25 (31.8)	1.75 (44.5)	0.24 (6.1)	1.20 (30.5)	0.63 (16.0)	94	Green
54922BEUB	750 kcmil	1,325/24, 500/535 kcmil	½		1.25 (31.8)	1.94 (49.3)	0.27 (6.9)	1.33 (33.8)	0.50 (12.7)	106	Black
54923BEUB	750 kcmil	1,325/24, 500/535 kcmil	⅝		1.58 (40.1)	1.94 (49.3)	0.27 (6.9)	1.33 (33.8)	0.63 (16.0)	106	Black
58984BEUB	–	1,600/24, 646 kcmil	⅝		1.58 (40.1)	1.94 (49.3)	0.27 (6.9)	1.33 (33.8)	0.63 (16.0)	106	Black
58926BEUB	900 kcmil	1,925/24, 777 kcmil	⅝		1.58 (40.1)	2.17 (55.1)	0.31 (7.9)	1.50 (38.1)	0.63 (16.0)	115	Yellow
54928BEUB	1,000 kcmil	–	⅝		1.58 (40.1)	2.27 (57.7)	0.30 (7.6)	1.55 (39.4)	0.63 (16.0)	125	–
54928BEUB12	1,000 kcmil	–	⅞		1.58 (46.5)	2.37 (60.2)	0.30 (7.6)	1.55 (39.4)	0.88 (22.4)	125	–

Diagrams

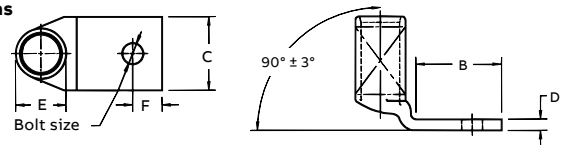

* For installations from 16 kV up to 35 kV, consult shielded cable manufacturers for stress relief and insulation requirements. Call your regional sales office for sizes not listed. For tool and die selection charts, see the section E31-E48 of the Tools, Dies and Kits catalogue.

Compression connectors for copper conductors



Peep holes available – Add suffix PH

Material – High-conductivity wrought copper

Finish – Electro tin plated



Two-hole lugs – Long barrel certified to 600 V and recommended up to 35 kV*

Cat no.	Code cable	Wire size			Dimensions in. (mm)								Die code	Colour code
		Flex cable classes G, H, I, K, M	Bolt size		A	B	C	D	E	F	H			
54801BE	#14–10 AWG	–	¼	1.86 (47.2)	1.19 (30.2)	0.50 (12.7)	0.05 (1.3)	0.20 (5.1)	0.25 (6.4)	0.63 (16.0)	ERG4002	Yellow		
256-31426-3	#14–10 AWG		#10	2.00 (50.8)	1.25 (31.2)	0.37 (9.4)	0.07 (1.8)	0.20 (5.1)	0.25 (6.4)	0.63 (16.0)	ERG4002			
256-31426-3SPH	#14–10 AWG		#10	2.00 (50.8)	1.25 (31.2)	0.37 (9.4)	0.07 (1.8)	0.20 (5.1)	0.22 (5.6)	0.63–0.75 (16.0)–(19.1)	ERG4002			
256-30695-1298	#14–10 AWG		¼	1.89 (48.0)	1.22 (31.0)	0.50 (12.7)	0.05 (1.3)	0.20 (5.1)	0.25 (6.4)	0.63 (16.0)	ERG4002			
256-30695-1730	#14–10 AWG		¼	1.98 (50.3)	1.31 (33.3)	0.50 (12.7)	0.05 (1.3)	0.20 (5.1)	0.25 (6.4)	0.63–0.75 (16.0)–(19.1)	ERG4002			
54850BE	#8 AWG	#8 AWG,	¼	2.19 (55.6)	1.89 (48.0)	0.42 (10.7)	0.07 (1.78)	0.26 (6.6)	0.25 (6.4)	0.63 (16.0)	21	Red		
54851BE	#8 AWG	#8 Weld	¼	2.31 (58.7)	1.29 (32.8)	0.47 (11.9)	0.06 (1.52)	0.26 (6.6)	0.25 (6.4)	0.75 (19.1)	21			
256-30695-1157	#8 AWG	37/24	¾	3.00 (76.2)	2.10 (53.3)	0.56 (14.2)	0.06 (1.52)	0.26 (6.6)	0.38 (9.7)	1.00 (25.4)	21			
54852BE	#6 AWG	#6 AWG,	¼	2.28 (57.9)	1.28 (32.5)	0.44 (11.1)	0.08 (2.03)	0.30 (7.6)	0.25 (6.4)	0.63 (16.0)	24	Blue		
256-30695-1014	#6 AWG	61/24,	¼	2.63 (66.8)	1.63 (41.4)	0.43 (10.9)	0.08 (2.03)	0.30 (7.6)	0.25 (6.4)	1.00 (25.4)	24			
256-30695-1225	#6 AWG	#6 Weld	¼	2.43 (61.7)	1.43 (36.3)	0.43 (10.9)	0.08 (2.03)	0.30 (7.6)	0.25 (6.4)	0.75 (19.1)	24			
256-30695-1158	#6 AWG		¾	2.93 (74.4)	1.93 (49.0)	0.59 (14.9)	0.06 (1.52)	0.30 (7.6)	0.38 (9.7)	1.00 (25.4)	24			
256-30695-868	#6 AWG		½	4.18 (106.2)	3.00 (76.2)	0.88 (22.4)	0.11 (2.8)	0.30 (7.6)	0.50 (12.7)	1.75 (44.5)	24			
54854BE	#4 AWG	91/24,	¼	2.31 (58.7)	1.19 (30.2)	0.52 (13.1)	0.10 (2.5)	0.37 (9.4)	0.25 (6.4)	0.63 (16.0)	29	Grey		
256-30695-1246	#4 AWG	#5 AWG,	¼	2.31 (54.1)	1.31 (33.3)	0.56 (14.2)	0.09 (2.3)	0.37 (9.4)	0.25 (6.4)	0.75 (19.1)	29			
256-30695-1015	#4 AWG	#4 Weld	¼	2.88 (73.2)	1.88 (47.8)	0.58 (14.7)	0.09 (2.3)	0.37 (9.4)	0.38 (9.7)	1.00 (25.4)	29			
256-30695-1337	#4 AWG		⅜	2.75 (69.9)	1.75 (44.5)	0.56 (14.2)	0.10 (2.5)	0.37 (9.4)	0.34 (8.4)	1.00 (25.4)	29			
256-30695-1159	#4 AWG		⅝	3.13 (79.5)	1.98 (50.3)	0.59 (14.9)	0.09 (2.3)	0.37 (9.4)	0.38 (9.7)	1.00 (25.4)	29			
256-30695-733	#4 AWG		½	4.18 (106.2)	3.00 (76.2)	0.88 (22.4)	0.09 (2.3)	0.37 (9.4)	0.50 (12.7)	1.75 (44.5)	29			
256-30695-1016*	#2–3 AWG	#3 AWG,	¼	3.06 (77.7)	1.88 (47.8)	0.67 (17.0)	0.09 (2.3)	0.41 (10.4)	0.38 (9.7)	1.00 (25.4)	33	Brown		
54855BE	#2–3 AWG	125/24	¼	2.43 (61.7)	1.28 (32.5)	0.59 (14.9)	0.11 (2.8)	0.41 (10.4)	0.50 (12.7)	0.63 (16.0)	33			
256-30695-1300	#2–3 AWG		¼	2.63 (66.8)	1.35 (34.3)	0.68 (17.3)	0.11 (2.8)	0.41 (10.4)	0.25 (6.4)	0.75 (19.1)	33			
54856BE	#2–3 AWG		⅜	2.78 (70.6)	1.63 (41.4)	0.59 (14.9)	0.11 (2.8)	0.41 (10.4)	0.38 (9.7)	0.75 (19.1)	33			
54810BE	#2–3 AWG		⅝	3.80 (96.5)	2.57 (65.3)	0.59 (14.9)	0.11 (2.8)	0.41 (10.4)	0.38 (9.7)	1.75 (44.5)	33			
256-30695-1160	#2–3 AWG		⅝	3.08 (78.2)	1.94 (49.3)	0.59 (14.9)	0.11 (2.8)	0.41 (10.4)	0.38 (9.7)	1.00 (25.4)	33			
256-30695-869	#2–3 AWG		½	4.02 (102.1)	2.88 (73.2)	0.25 (6.4)	0.75 (19.1)	0.41 (10.4)	0.63 (16.0)	1.75 (44.5)	33			
54811BE	#2–3 AWG		½	4.28 (108.7)	3.00 (76.2)	0.88 (22.4)	0.11 (2.8)	0.41 (10.4)	0.50 (12.7)	1.75 (44.5)	33			
54809BE	#1 AWG	#2 AWG	¼	2.88 (73.2)	1.19 (30.2)	0.67 (17.0)	0.11 (2.8)	0.47 (11.9)	0.25 (6.4)	0.63 (16.0)	37		Green	
54812BE	#1 AWG	150/24	¼	2.75 (69.9)	1.40 (35.6)	0.67 (17.0)	0.11 (2.8)	0.47 (11.9)	0.25 (6.4)	0.75 (19.1)	37			
54858BE	#1 AWG	175/24	⅜	2.94 (75.4)	1.63 (41.4)	0.67 (17.0)	0.11 (2.8)	0.47 (11.9)	0.38 (9.7)	0.88 (22.4)	37			
256-30695-1161	#1 AWG	#2 Weld	⅝	3.30 (83.8)	1.98 (50.3)	0.67 (17.0)	0.11 (2.8)	0.47 (11.9)	0.38 (9.7)	1.00 (25.4)	37			
54857BE	#1 AWG		½	4.43 (112.5)	3.00 (76.2)	0.88 (22.4)	0.11 (2.8)	0.47 (11.9)	0.50 (12.7)	1.75 (44.5)	37			

Diagrams

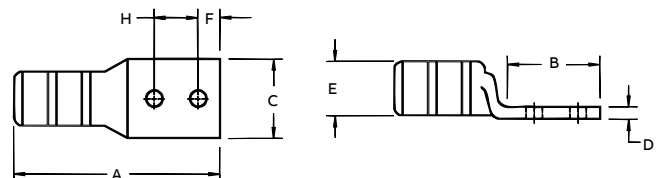

* CSA not applicable

For installations from 16 kV up to 35 kV, consult shielded cable manufacturers for stress relief and insulation requirements. Call your regional sales office for sizes not listed. For tool and die selection charts, see the section E31-E48 of the Tools, Dies and Kits catalogue.

Compression connectors for copper conductors



Peep holes available – Add suffix PH

Material – High-conductivity wrought copper

Finish – Electro tin plated



Two-hole lugs – Long barrel certified to 600 V and recommended up to 35 kV* (continued)

Cat no.	Code cable	Wire size		Dimensions in. (mm)								Die code	Colour code
		Flex cable classes G, H, I, K, M	Bolt size	A	B	C	D	E	F	H			
256-30695-1018	1/0 AWG	#1 AWG, 225/24	¼	3.63 (92.2)	1.88 (47.8)	0.75 (19.0)	0.13 (3.3)	0.52 (13.2)	0.38 (9.7)	1.00 (25.4)	42	Pink	
256-30695-1018P	1/0 AWG		¼	3.63 (92.2)	1.88 (47.8)	0.75 (19.0)	0.13 (3.3)	0.52 (13.2)	0.38 (9.7)	1.00 (25.4)	42		
54859BE	1/0 AWG		¼	2.63 (66.8)	1.19 (30.2)	0.75 (19.0)	0.13 (3.3)	0.52 (13.2)	0.25 (6.4)	0.63 (16.0)	42		
54813BE	1/0 AWG		¼	2.71 (68.8)	1.38 (35.1)	0.75 (19.0)	0.13 (3.3)	0.52 (13.2)	0.25 (6.4)	0.75 (19.1)	42		
54860BE	1/0 AWG		⅝ ₁₆	2.97 (75.4)	1.63 (41.4)	0.75 (19.0)	0.13 (3.3)	0.52 (13.2)	0.50 (12.7)	0.88 (22.4)	42		
256-30695-1162P	1/0 AWG		⅝ ₈	3.25 (82.3)	1.98 (50.3)	0.75 (19.0)	0.13 (3.3)	0.52 (13.2)	0.38 (9.7)	1.00 (25.4)	42		
256-30695-1162	1/0 AWG		⅝ ₈	3.23 (82.0)	1.93 (49.0)	0.75 (19.0)	0.13 (3.3)	0.52 (13.2)	0.38 (9.7)	1.00 (25.4)	42		
256-30695-593	1/0 AWG		½	4.33 (110.0)	3.00 (76.2)	0.75 (19.0)	0.13 (3.3)	0.52 (13.2)	0.63 (16.0)	1.75 (44.5)	42		
54814BE	2/0 AWG	1/0 AWG, 1/0 Weld 275/24	¼	2.62 (66.5)	1.25 (31.8)	0.83 (21.1)	0.13 (3.3)	0.57 (14.5)	0.25 (6.4)	0.63 (16.0)	45	Black	
256-30695-1299	2/0 AWG		¼	2.69 (68.3)	1.31 (33.3)	0.81 (20.6)	0.13 (3.3)	0.57 (14.5)	0.25 (6.4)	0.75 (19.1)	45		
256-30695-1116	2/0 AWG		⅝ ₈	3.19 (81.0)	1.81 (46.0)	0.83 (21.1)	0.13 (3.3)	0.57 (14.5)	0.38 (9.7)	1.00 (25.4)	45		
256-30695-1116P	2/0 AWG		⅝ ₈	3.19 (81.0)	1.81 (46.0)	0.83 (21.1)	0.13 (3.3)	0.57 (14.5)	0.38 (9.7)	1.00 (25.4)	45		
54862BE	2/0 AWG		½	4.20 (106.7)	2.81 (71.4)	0.83 (21.1)	0.13 (3.3)	0.57 (14.5)	0.50 (12.7)	1.75 (44.5)	45		
54815BE	3/0 AWG	2/0 AWG, 2/0 Weld 325/24	¼	2.89 (73.4)	1.45 (36.8)	0.92 (23.4)	0.13 (3.3)	0.63 (16.0)	0.25 (6.4)	0.75 (19.1)	50	Orange	
54816BE	3/0 AWG		⅝ ₈	3.25 (82.6)	1.63 (41.4)	0.92 (23.4)	0.13 (3.3)	0.63 (16.0)	0.38 (9.7)	1.00 (25.4)	50		
54864BE	3/0 AWG		½	4.48 (113.8)	3.00 (76.2)	0.94 (23.9)	0.13 (3.3)	0.63 (16.0)	0.50 (12.7)	1.75 (44.5)	50		
54817BE	4/0 AWG	3/0 AWG, 3/0 Weld 450/24	¼	3.15 (80.0)	1.38 (35.1)	1.03 (33.0)	0.14 (3.6)	0.70 (17.8)	0.25 (6.4)	0.75 (19.1)	54	Purple	
54818BE	4/0 AWG		⅝ ₈	4.38 (111.3)	2.63 (66.8)	1.03 (33.0)	0.14 (3.6)	0.70 (17.8)	0.38 (9.7)	1.75 (44.5)	54		
256-30695-1117	4/0 AWG		⅝ ₈	3.35 (85.1)	1.81 (46.0)	1.03 (33.0)	0.14 (3.6)	0.70 (17.8)	0.38 (9.7)	1.00 (25.4)	54		
256-30695-1117P	4/0 AWG		⅝ ₈	3.50 (88.9)	1.88 (47.8)	1.03 (33.0)	0.14 (3.6)	0.70 (17.8)	0.38 (9.7)	1.00 (25.4)	54		
54866BE	4/0 AWG		½	4.70 (119.4)	3.00 (76.2)	1.03 (33.0)	0.14 (3.6)	0.70 (17.8)	0.50 (12.7)	1.75 (44.5)	54		
256-30695-1245	250 kcmil	4/0 AWG, 4/0 Weld 550/24	⅝ ₈	3.83 (97.3)	1.93 (49.0)	1.13 (28.7)	0.14 (3.6)	0.77 (19.6)	0.38 (9.7)	1.00 (25.4)	62	Yellow	
256-30695-1245P	250 kcmil		⅝ ₈	3.83 (97.3)	1.93 (49.0)	1.13 (28.7)	0.14 (3.6)	0.77 (19.6)	0.38 (9.7)	1.00 (25.4)	62		
54868BE	250 kcmil		½	4.92 (125.0)	3.00 (76.2)	1.13 (28.7)	0.14 (3.6)	0.77 (19.6)	0.50 (12.7)	1.75 (44.5)	62		
54819BE	300 kcmil	250 kcmil 650/24 = 262 kcmil	⅝ ₈	5.04 (137.2)	2.80 (71.1)	1.25 (31.8)	0.15 (3.8)	0.85 (21.6)	0.38 (9.7)	1.00 (25.4)	66	White	
54870BE	300 kcmil		½	5.23 (132.8)	3.00 (76.2)	1.25 (31.8)	0.15 (3.8)	0.85 (21.6)	0.50 (12.7)	1.75 (44.5)	66		
54820BE	350 kcmil	–	¼	4.29 (109.0)	1.93 (49.0)	1.36 (34.5)	0.18 (4.6)	0.93 (23.6)	0.25 (6.4)	1.75 (44.5)	71	Red	
256-30695-1118	350 kcmil		⅝ ₈	4.33 (110.0)	1.93 (49.0)	1.36 (34.5)	0.18 (4.6)	0.93 (23.6)	0.38 (9.7)	1.00 (25.4)	71		
256-30695-1118P	350 kcmil		⅝ ₈	4.33 (110.0)	1.93 (49.0)	1.36 (34.5)	0.18 (4.6)	0.93 (23.6)	0.38 (9.7)	1.00 (25.4)	71		
54872BE	350 kcmil		½	5.40 (137.2)	3.00 (76.2)	1.36 (34.5)	0.18 (4.6)	0.93 (23.6)	0.50 (12.7)	1.75 (44.5)	71		

Diagrams

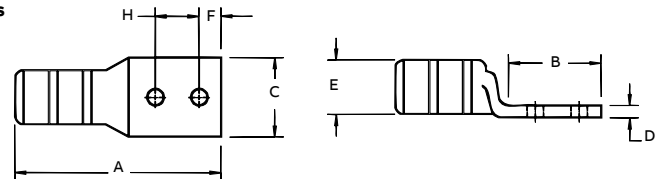

* For installations from 16 kV up to 35 kV, consult shielded cable manufacturers for stress relief and insulation requirements. Call your regional sales office for sizes not listed. For tool and die selection charts, see the section E31-E48 of the Tools, Dies and Kits catalogue.

Compression connectors for copper conductors



Peep holes available – Add suffix PH

Material – High-conductivity wrought copper

Finish – Electro tin plated



Two-hole lugs – Long barrel certified to 600 V and recommended up to 35 kV^y (continued)

Cat no.	Code cable	Wire size			Dimensions in. (mm)							Die code	Colour code
		Flex cable classes G, H, I, K, M	Bolt size		A	B	C	D	E	F	H		
54822BE	400 kcmil	300 kcmil	¼	4.38 (111.3)	1.93 (49.0)	1.41 (35.8)	0.17 (4.3)	0.96 (24.4)	0.25 (6.4)	0.75 (19.1)	76	Blue	
54821BE	400 kcmil	775/24, 313 kcmil	⅜	4.43 (112.5)	1.93 (49.0)	1.41 (35.8)	0.17 (4.3)	0.96 (24.4)	0.38 (9.7)	1.00 (25.4)	76		
54874BE	400 kcmil		½	5.51 (140.0)	3.00 (76.2)	1.41 (35.8)	0.17 (4.3)	0.96 (24.4)	0.50 (12.7)	1.75 (44.5)	76		
54823BE	500 kcmil	400 kcmil	¼	4.93 (125.2)	1.94 (49.3)	1.61 (40.9)	0.22 (5.6)	1.10 (27.9)	0.25 (6.4)	0.75 (19.1)	87	Brown	
256-30695-1119	500 kcmil	925/24, 350/373 kcmil	⅜	5.00 (127.0)	1.93 (49.0)	1.61 (40.9)	0.22 (5.6)	1.10 (27.9)	0.38 (9.7)	1.00 (25.4)	87		
256-30695-1119P	500 kcmil		⅝	5.00 (127.0)	1.93 (49.0)	1.61 (40.9)	0.22 (5.6)	1.10 (27.9)	0.38 (9.7)	1.00 (25.4)	87		
54876BE	500 kcmil		½	6.00 (152.4)	3.00 (76.2)	1.61 (40.9)	0.22 (5.6)	1.10 (27.9)	0.50 (12.7)	1.75 (44.5)	87		
54824BE	600 kcmil	1100/24, 444 kcmil	⅜	5.70 (144.8)	2.80 (71.1)	1.75 (44.5)	0.24 (6.1)	1.20 (30.5)	0.38 (9.7)	1.00 (25.4)	94	Green	
54878BE	600 kcmil		½	5.83 (148.1)	3.00 (76.2)	1.75 (44.5)	0.24 (6.1)	1.20 (30.5)	0.50 (12.7)	1.75 (44.5)	94		
54879BE	700 kcmil	1,325/24, 535 kcmil	½	5.83 (148.1)	3.00 (76.2)	1.80 (45.7)	0.24 (6.1)	1.25 (31.8)	0.50 (12.7)	1.75 (44.5)	99	Pink	
256-30695-1222	750 kcmil	1325/24, 535 kcmil	⅝	5.25 (133.4)	2.06 (52.3)	1.94 (49.3)	0.27 (6.7)	1.33 (33.8)	0.50 (12.7)	1.00 (25.4)	106	Black	
256-30695-1222P	750 kcmil		⅝	5.25 (133.4)	2.06 (52.3)	1.94 (49.3)	0.27 (6.7)	1.33 (33.8)	0.50 (12.7)	1.00 (25.4)	106		
54880BE	750 kcmil		½	6.20 (157.5)	3.00 (76.2)	1.94 (49.3)	0.27 (6.9)	1.33 (33.8)	0.50 (12.7)	1.75 (44.5)	106		
58884BE	–	1,600/24, 646 kcmil	½	6.16 (156.5)	3.00 (76.2)	1.94 (49.3)	0.27 (6.9)	1.33 (33.8)	0.50 (12.7)	1.75 (44.5)	106		
58826BE	900 kcmil	1,925/24, 777 kcmil	½	6.74 (171.2)	3.00 (76.2)	2.18 (55.4)	0.31 (7.9)	1.50 (38.1)	0.50 (12.7)	1.75 (44.5)	115	Yellow	
54826BE	1,000 kcmil	–	⅝	6.49 (164.8)	2.80 (71.1)	2.27 (57.7)	0.30 (7.6)	1.55 (39.4)	0.38 (9.7)	1.00 (25.4)	125	–	
54882BE	1,000 kcmil		½	6.66 (169.2)	3.00 (76.2)	2.27 (57.7)	0.30 (7.6)	1.55 (39.4)	0.38 (9.7)	1.75 (44.5)	125		
54888BE	1,250 kcmil		½	7.88 (200.2)	3.00 (76.2)	2.42 (61.5)	0.35 (8.9)	1.67 (42.4)	0.63 (16.0)	1.75 (44.5)	140		

Diagrams

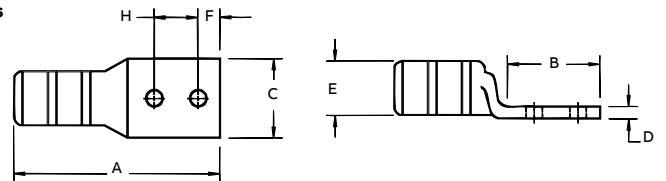

^y For installations from 16 kV up to 35 kV, consult shielded cable manufacturers for stress relief and insulation requirements. Call your regional sales office for sizes not listed. For tool and die selection charts, see the section E31-E48 of the Tools, Dies and Kits catalogue.

Compression connectors for copper conductors



Peep holes available – Add suffix PH

Material – High-conductivity wrought copper

Finish – Electro tin plated



Two-hole lugs – 45° Long barrel certified to 600 V and recommended up to 35 kV*

Cat no.	Code cable	Wire size		Dimensions in. (mm)							Die code	Colour code
		Flex cable classes G, H, I, K, M	Bolt size	B	C	D	E	F	G			
256-31426-3SPHUF	#14-10 AWG	-	#10	1.25 (31.75)	0.37 (9.4)	0.07 (1.8)	0.20 (5.1)	0.22 (5.6)	0.50-0.63 (12.7-16.0)	ERG2002	Yellow	
256-30695-1298UF	#14-10 AWG		¼	1.22 (31.0)	0.50 (12.7)	0.05 (1.3)	0.20 (5.1)	0.25 (6.4)	0.63 (16.0)	ERG2002	Red	
54850BEUF	#8 AWG	#8 AWG	¼	1.89 (48.0)	0.42 (10.7)	0.07 (17.8)	0.26 (6.6)	0.25 (6.4)	0.63 (16.0)	21		
54851BEUF	#8 AWG	37/24	¼	1.29 (32.8)	0.47 (11.9)	0.06 (15.2)	0.26 (6.6)	0.25 (6.4)	0.75 (19.1)	21	Blue	
54851BEUF0612	#8 AWG	#8 Weld	¾	1.42 (36.1)	0.47 (11.9)	0.06 (15.2)	0.26 (6.6)	0.38 (9.7)	0.75 (19.1)	21		
54852BEUF	#6 AWG	#6 AWG	¼	1.28 (32.5)	0.44 (11.2)	0.08 (20.3)	0.30 (7.6)	0.25 (6.4)	0.63 (16.0)	24	Grey	
54852BEUF0416	#6 AWG	61/24	¼	1.63 (41.4)	0.43 (10.9)	0.08 (20.3)	0.30 (7.6)	0.25 (6.4)	1.00 (25.4)	24		
54852BEUF0412	#6 AWG	#6 Weld	¼	1.43 (36.3)	0.43 (10.9)	0.08 (20.3)	0.30 (7.6)	0.25 (6.4)	0.75 (19.1)	24		
54852BEUF0616	#6 AWG		¾	1.93 (49.0)	0.59 (15.0)	0.06 (15.2)	0.30 (7.6)	0.38 (9.7)	1.00 (25.4)	24		
54852BEUF0828	#6 AWG		½	3.00 (76.2)	0.88 (22.4)	0.11 (2.8)	0.30 (7.6)	0.50 (12.7)	1.75 (44.5)	24		
54854BEUF	#4 AWG	#5 AWG	¼	1.19 (30.2)	0.52 (13.2)	0.10 (2.5)	0.37 (9.4)	0.25 (6.4)	0.63 (16.0)	29	Brown	
54854BEUF0412	#4 AWG	91/24	¼	1.31 (33.3)	0.56 (14.2)	0.09 (2.3)	0.37 (9.4)	0.25 (6.4)	0.75 (19.1)	29		
54854BEUF0416	#4 AWG	#4 Weld	¼	1.88 (47.8)	0.58 (14.7)	0.09 (2.3)	0.37 (9.4)	0.38 (9.7)	1.00 (25.4)	29		
54854BEUF0516	#4 AWG		⅝	1.75 (44.5)	0.56 (14.2)	0.10 (2.5)	0.37 (9.4)	0.63 (16.0)	1.00 (25.4)	29		
54854BEUF0616	#4 AWG		¾	1.98 (50.3)	0.59 (15.0)	0.09 (2.3)	0.37 (9.4)	0.38 (9.7)	1.00 (25.4)	29		
54854BEUF0828	#4 AWG		½	3.00 (76.2)	0.88 (22.4)	0.09 (2.3)	0.37 (9.4)	0.50 (12.7)	1.75 (44.5)	29		
54855BEUF0416	#2-3 AWG	#3 AWG	¼	1.88 (47.8)	0.67 (17.0)	0.09 (2.3)	0.41 (10.4)	0.38 (9.7)	1.00 (25.4)	33	Green	
54855BEUF	#2-3 AWG	125/24	¼	1.28 (32.5)	0.59 (15.0)	0.11 (2.8)	0.41 (10.4)	0.25 (6.4)	0.63 (16.0)	33		
54855BEUF0412	#2-3 AWG		¼	1.35 (34.3)	0.68 (17.3)	0.11 (2.8)	0.41 (10.4)	0.25 (6.4)	0.75 (19.1)	33		
54856BEUF	#2-3 AWG		⅝	1.63 (41.4)	0.59 (15.0)	0.11 (2.8)	0.41 (10.4)	0.38 (9.7)	0.75 (19.1)	33		
54810BEUF	#2-3 AWG		¾	2.57 (65.3)	0.59 (15.0)	0.11 (2.8)	0.41 (10.4)	0.38 (9.7)	1.75 (44.5)	33		
54810BEUF0616	#2-3 AWG		¾	1.94 (49.3)	0.59 (15.0)	0.11 (2.8)	0.41 (10.4)	0.38 (9.7)	1.00 (25.4)	33		
54811BEUF	#2-3 AWG		½	3.00 (76.2)	0.88 (22.4)	0.11 (2.8)	0.41 (10.4)	0.50 (12.7)	1.75 (44.5)	33		
54809BEUF	#1 AWG	#2 AWG	¼	1.19 (30.2)	0.67 (17.0)	0.11 (2.8)	0.47 (11.9)	0.25 (6.4)	0.63 (16.0)	37	Green	
54812BEUF	#1 AWG	150/24	¼	1.40 (35.6)	0.67 (17.0)	0.11 (2.8)	0.47 (11.9)	0.25 (6.4)	0.75 (19.1)	37		
54858BEUF	#1 AWG	175/24	⅝	1.63 (41.4)	0.67 (17.0)	0.11 (2.8)	0.47 (11.9)	0.63 (16.0)	0.88 (22.4)	37		
54857BEUF0616	#1 AWG	#2 Weld	¾	1.98 (50.3)	0.67 (17.0)	0.11 (2.8)	0.47 (11.9)	0.38 (9.7)	1.00 (25.4)	37		
54857BEUF	#1 AWG		½	3.00 (76.2)	0.88 (22.4)	0.11 (2.8)	0.47 (11.9)	0.50 (12.7)	1.75 (44.5)	37		

Diagrams

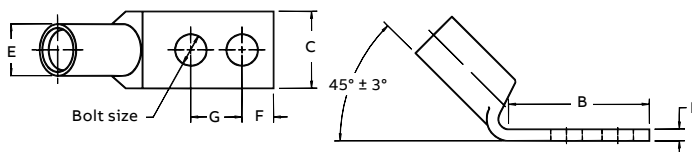

* For installations from 16 kV up to 35 kV, consult shielded cable manufacturers for stress relief and insulation requirements. Call your regional sales office for sizes not listed. For tool and die selection charts, see the section E31-E48 of the Tools, Dies and Kits catalogue.

Compression connectors for copper conductors



Peep holes available – Add suffix PH

Material – High-conductivity wrought copper

Finish – Electro tin plated



Two-hole lugs – 45° Long barrel certified to 600 V and recommended up to 35 kV* (continued)

Cat no.	Code cable	Wire size		Dimensions in. (mm)							Die code	Colour code
		Flex cable classes G, H, I, K, M	Bolt size	B	C	D	E	F	G			
54859BEUF0416	1/0 AWG	1 AWG 225/24	¼	1.88 (47.8)	0.75 (19.1)	0.13 (3.3)	0.52 (13.2)	0.38 (9.7)	1.00 (25.4)	42	Pink	
54859BEUF0416PH	1/0 AWG		¼	1.88 (47.8)	0.75 (19.1)	0.13 (3.3)	0.52 (13.2)	0.38 (9.7)	1.00 (25.4)	42		
54859BEUF	1/0 AWG	¼	1.19 (30.2)	0.75 (19.1)	0.13 (3.3)	0.52 (13.2)	0.25 (6.4)	0.38 (9.7)	42			
54813BEUF	1/0 AWG	¼	1.38 (35.1)	0.75 (19.1)	0.13 (3.3)	0.52 (13.2)	0.25 (6.4)	0.75 (19.1)	42			
54860BEUF	1/0 AWG	5/16	1.63 (41.4)	0.75 (19.1)	0.13 (3.3)	0.52 (13.2)	0.38 (9.7)	0.88 (22.4)	42			
54860BEUF0616	1/0 AWG	¾	1.98 (50.3)	0.75 (19.1)	0.13 (3.3)	0.52 (13.2)	0.38 (9.7)	1.00 (25.4)	42			
54860BEUF0616PH	1/0 AWG	¾	1.93 (49.0)	0.75 (19.1)	0.13 (3.3)	0.52 (13.2)	0.38 (9.7)	1.00 (25.4)	42			
54860BEUF0828	1/0 AWG	½	3.00 (76.0)	0.75 (19.1)	0.13 (3.3)	0.52 (13.2)	0.63 (16.0)	1.75 (44.5)	42			
54814BEUF	2/0 AWG	1/0 AWG 275/24	¼	1.25 (31.8)	0.83 (21.1)	0.13 (3.3)	0.57 (14.5)	0.25 (6.4)	0.63 (16.0)	45		Black
54814BEUF0412	2/0 AWG		¼	1.31 (33.3)	0.81 (20.6)	0.13 (3.3)	0.57 (14.5)	0.25 (6.4)	0.75 (19.1)	45		
54862BEUF0616	2/0 AWG	1/0 Weld	¾	1.81 (46.0)	0.83 (21.1)	0.13 (3.3)	0.57 (14.5)	0.38 (9.7)	1.00 (25.4)	45		
54862BEUF0616PH	2/0 AWG	¾	1.81 (46.0)	0.83 (21.1)	0.13 (3.3)	0.57 (14.5)	0.38 (9.7)	1.00 (25.4)	45			
54862BEUF	2/0 AWG	½	2.81 (71.4)	0.83 (21.1)	0.13 (3.3)	0.57 (14.5)	0.50 (12.7)	1.75 (44.5)	45			
54815BEUF	3/0 AWG	2/0 AWG 325/24	¼	1.45 (36.8)	0.92 (23.4)	0.13 (3.3)	0.63 (16.0)	0.25 (6.4)	0.75 (19.1)	50	Orange	
54816BEUF	3/0 AWG		¾	0.63 (41.4)	0.92 (23.4)	0.13 (3.3)	0.63 (16.0)	0.38 (9.7)	1.00 (25.4)	50		
54864BEUF	3/0 AWG	2/0 Weld	½	3.00 (76.2)	0.94 (23.9)	0.13 (3.3)	0.63 (16.0)	0.50 (12.7)	1.75 (44.5)	50		
54817BEUF	4/0 AWG	3/0 AWG 450/24	¼	1.38 (35.1)	1.03 (33.0)	0.14 (3.6)	0.70 (17.8)	0.25 (6.4)	0.75 (19.1)	54	Purple	
54818BEUF	4/0 AWG		¾	2.63 (66.8)	1.03 (33.0)	0.14 (3.6)	0.70 (17.8)	0.38 (9.7)	1.75 (44.5)	54		
54818BEUF0616	4/0 AWG	3/0 Weld	¾	1.81 (46.0)	1.03 (33.0)	0.14 (3.6)	0.70 (17.8)	0.38 (9.7)	1.00 (25.4)	54		
54818BEUF0616PH	4/0 AWG	¾	1.88 (47.8)	1.03 (33.0)	0.14 (3.6)	0.70 (17.8)	0.38 (9.7)	1.00 (25.4)	54			
54866BEUF	4/0 AWG	½	3.00 (76.2)	1.03 (33.0)	0.14 (3.6)	0.70 (17.8)	0.50 (12.7)	1.75 (44.5)	54			
54868BEUF0616	250 kcmil	4/0 AWG 550/24	¾	1.93 (49.0)	1.13 (28.7)	0.14 (3.6)	0.77 (19.6)	0.38 (9.7)	1.00 (25.4)	62	Yellow	
54868BEUF0616PH	250 kcmil		5/8	1.93 (49.0)	1.13 (28.7)	0.14 (3.6)	0.77 (19.6)	0.38 (9.7)	1.00 (25.4)	62		
54868BEUF	250 kcmil	4/0 Weld	½	3.00 (76.2)	1.13 (28.7)	0.14 (3.6)	0.77 (19.6)	0.50 (12.7)	1.75 (44.5)	62		
54819BEUF	300 kcmil	250 kcmil 650/24 = 262 kcmil	¾	2.80 (71.1)	1.25 (31.8)	0.15 (3.8)	0.85 (21.6)	0.38 (9.7)	1.00 (25.4)	66	White	
54870BEUF	300 kcmil		½	3.00 (76.2)	1.25 (31.8)	0.15 (3.8)	0.85 (21.6)	0.50 (12.7)	1.75 (44.5)	66		
54820BEUF	350 kcmil	650/24 262 kcmil	¼	1.93 (49.0)	1.36 (34.5)	0.18 (4.6)	0.93 (23.6)	0.25 (6.4)	0.75 (19.1)	71	Red	
54872BEUF0616	350 kcmil		¾	1.93 (49.0)	1.36 (34.5)	0.18 (4.6)	0.93 (23.6)	0.38 (9.7)	1.00 (25.4)	71		
54872BEUF0616PH	350 kcmil		¾	1.93 (49.0)	1.36 (34.5)	0.18 (4.6)	0.93 (23.6)	0.38 (9.7)	1.00 (25.4)	71		
54872BEUF	350 kcmil		½	3.00 (76.2)	1.36 (34.5)	0.18 (4.6)	0.93 (23.6)	0.50 (12.7)	1.75 (44.5)	71		

Diagrams

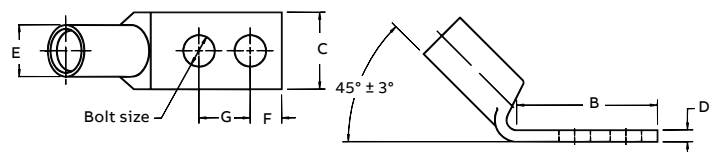

* For installations from 16 kV up to 35 kV, consult shielded cable manufacturers for stress relief and insulation requirements. Call your regional sales office for sizes not listed. For tool and die selection charts, see the section E31-E48 of the Tools, Dies and Kits catalogue.

Compression connectors for copper conductors



Peep holes available – Add suffix PH

Material – High-conductivity wrought copper

Finish – Electro tin plated



Two-hole lugs – 45° Long barrel certified to 600 V and recommended up to 35 kV* (continued)

Cat no.	Code cable	Wire size		Dimensions in. (mm)							Die code	Colour code
		Flex cable classes G, H, I, K, M	Bolt size	B	C	D	E	F	G			
54822BEUF	400 kcmil	775/24	¼	1.93 (49.0)	1.41 (35.8)	0.17 (4.3)	0.96 (24.4)	0.25 (6.4)	0.75 (19.1)	76	Blue	
54821BEUF	400 kcmil	313 kcmil	⅜	1.93 (49.0)	1.41 (35.8)	0.17 (4.3)	0.96 (24.4)	0.38 (9.7)	1.00 (25.4)	76		
54874BEUF	400 kcmil		½	3.00 (76.2)	1.41 (35.8)	0.17 (4.3)	0.96 (24.4)	0.50 (12.7)	1.75 (44.5)	76		
54823BEUF	500 kcmil	400 kcmil	¼	1.93 (49.0)	1.61 (40.9)	0.22 (5.6)	1.10 (27.9)	0.25 (6.4)	0.75 (19.1)	87	Brown	
54876BEUF0616	500 kcmil	925/24	⅜	1.93 (49.0)	1.61 (40.9)	0.22 (5.6)	1.10 (27.9)	0.38 (9.7)	1.00 (25.4)	87		
54876BEUF0616PH	500 kcmil	350/373 kcmil	⅜	1.93 (49.0)	1.61 (40.9)	0.22 (5.6)	1.10 (27.9)	0.38 (9.7)	1.00 (25.4)	87		
54876BEUF	500 kcmil		½	3.00 (76.2)	1.61 (40.9)	0.22 (5.6)	1.10 (27.9)	0.50 (12.7)	1.75 (44.5)	87		
54824BEUF	600 kcmil	1,100/24	⅜	2.80 (71.1)	1.75 (44.5)	0.24 (6.1)	1.20 (27.9)	0.38 (9.7)	1.00 (25.4)	94	Green	
54878BEUF	600 kcmil	444 kcmil	½	3.00 (76.2)	1.75 (44.5)	0.24 (6.1)	1.20 (27.9)	0.50 (12.7)	1.75 (44.5)	94		
54880BEUF0616	750 kcmil	1,325/24	⅜	2.06 (52.3)	1.94 (49.3)	0.27 (6.9)	1.33 (33.8)	0.50 (12.7)	1.00 (25.4)	106	Black	
54880BEUF0616PH	750 kcmil	535 kcmil	⅜	2.06 (52.3)	1.94 (49.3)	0.27 (6.9)	1.33 (33.8)	0.50 (12.7)	1.00 (25.4)	106		
54880BEUF	750 kcmil		½	3.00 (76.2)	1.94 (49.3)	0.27 (6.9)	1.33 (33.8)	0.50 (12.7)	1.75 (44.5)	106		
58884BEUF	–	1,600/24, 646 kcmil	½	3.00 (76.2)	1.94 (49.3)	0.27 (6.9)	1.33 (33.8)	0.50 (12.7)	1.75 (44.5)	106		
58826BEUF	900 kcmil	1,925/24 750/777 kcmil	½	3.00 (76.2)	2.18 (55.4)	0.31 (7.9)	1.50 (38.1)	0.50 (12.7)	1.75 (44.5)	115	Yellow	
54826BEUF	1,000 kcmil	–	⅜	2.80 (71.1)	2.27 (57.7)	0.30 (7.6)	1.55 (39.4)	0.38 (9.7)	1.00 (25.4)	125	–	
54882BEUF	1,000 kcmil	–	½	3.00 (76.2)	2.27 (57.7)	0.30 (7.6)	1.55 (39.4)	0.50 (12.7)	1.75 (44.5)	125	–	

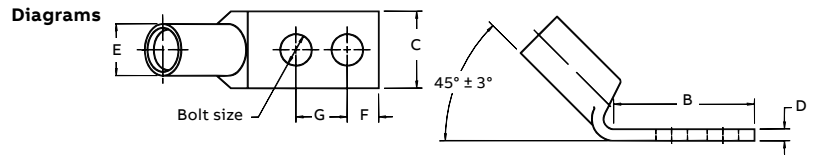

* For installations from 16 kV up to 35 kV, consult shielded cable manufacturers for stress relief and insulation requirements. Call your regional sales office for sizes not listed. For tool and die selection charts, see the section E31-E48 of the Tools, Dies and Kits catalogue.

Compression connectors for copper conductors



Peep holes available – Add suffix PH

Material – High-conductivity wrought copper

Finish – Electro tin plated



Two-hole lugs – 90° Long barrel certified to 600 V and recommended up to 35 kV*

Cat no.	Code Flex cable classes cable	Wire size		Dimensions in. (mm)						Die code	Colour code
		G, H, I, K, M	Bolt size	B	C	D	E	F	G		
54850BEUB	#8 AWG	#8 AWG 37/24	¼	1.89 (48.0)	0.42 (10.7)	0.07 (1.8)	0.26 (6.6)	0.21 (5.3)	0.63–0.75 (16.0–19.1)	21	Red
54851BEUB	#8 AWG	#8 Weld	¼	0.29 (32.8)	0.47 (11.9)	0.06 (1.5)	0.26 (6.6)	0.25 (6.4)	0.75 (19.1)	21	
54851BEUB0616	#8 AWG		¾	2.10 (53.3)	0.56 (14.2)	0.06 (1.5)	0.26 (6.6)	0.38 (9.7)	1.00 (25.4)	21	
54852BEUB	#6 AWG	#6 AWG 61/24	¼	1.28 (32.5)	0.44 (11.2)	0.08 (2.0)	0.30 (7.6)	0.25 (6.4)	0.63 (16.0)	24	Blue
54852BEUB0412	#6 AWG	#6 Weld	¼	1.43 (36.3)	0.43 (10.9)	0.08 (2.0)	0.30 (7.6)	0.25 (6.4)	0.75 (19.1)	24	
54852BEUB0616	#6 AWG		¾	1.93 (49.0)	0.59 (15.0)	0.06 (1.5)	0.30 (7.6)	0.38 (9.7)	1.00 (25.4)	24	
54852BEUB0828	#6 AWG		½	3.00 (76.2)	0.88 (22.4)	0.11 (2.8)	0.30 (7.6)	0.50 (12.7)	1.75 (44.5)	24	
54854BEUB	#4 AWG	#5 AWG 91/24	¼	1.19 (30.2)	0.52 (13.2)	0.10 (2.5)	0.37 (9.4)	0.25 (6.4)	0.63 (16.0)	29	Grey
54854BEUB0412	#4 AWG	#4 Weld	¼	1.31 (33.3)	0.56 (14.2)	0.09 (2.3)	0.37 (9.4)	0.25 (6.4)	0.75 (19.1)	29	
54854BEUB0416	#4 AWG		¼	1.88 (47.8)	0.58 (14.7)	0.09 (2.3)	0.37 (9.4)	0.38 (9.7)	1.00 (25.4)	29	
54854BEUB0516	#4 AWG		⅝	1.75 (44.5)	0.56 (14.2)	0.10 (2.5)	0.37 (9.4)	0.38 (9.7)	1.00 (25.4)	29	
54854BEUB0616	#4 AWG		¾	1.98 (50.3)	0.59 (15.0)	0.09 (2.3)	0.37 (9.4)	0.38 (9.7)	1.00 (25.4)	29	
54854BEUB0828	#4 AWG		½	3.00 (76.2)	0.88 (22.4)	0.09 (2.3)	0.37 (9.4)	0.50 (12.7)	1.75 (44.5)	29	
54858BEUB0416	#2–3AWG	#3 AWG 125/24	¼	1.88 (47.8)	0.67 (17.0)	0.09 (2.3)	0.41 (10.4)	0.38 (9.7)	1.00 (25.4)	33	
54855BEUB	#2–3AWG		¼	1.28 (32.5)	0.59 (15.0)	0.11 (2.8)	0.41 (10.4)	0.25 (6.4)	0.63 (16.0)	33	
54855BEUB0412	#2–3AWG		¼	1.35 (34.3)	0.68 (17.3)	0.11 (2.8)	0.41 (10.4)	0.25 (6.4)	0.75 (19.1)	33	
54856BEUB	#2–3AWG		⅝	1.63 (41.4)	0.59 (15.0)	0.11 (2.8)	0.41 (10.4)	0.38 (9.7)	0.75 (19.1)	33	
54810BEUB	#2–3AWG		¾	2.57 (65.3)	0.59 (15.0)	0.11 (2.8)	0.41 (10.4)	0.38 (9.7)	1.75 (44.5)	33	
54810BEUB0616	#2–3AWG		¾	1.94 (49.3)	0.59 (15.0)	0.11 (2.8)	0.41 (10.4)	0.38 (9.7)	1.00 (25.4)	33	
54811BEUB	#2–3AWG		½	3.00 (76.2)	0.88 (22.4)	0.11 (2.8)	0.41 (10.4)	0.50 (12.7)	0.75 (19.1)	33	
54809BEUB	#1 AWG	#2 AWG 150/24	¼	1.19 (30.2)	0.67 (17.0)	0.11 (2.8)	0.47 (11.9)	0.25 (6.4)	0.63 (16.0)	37	Green
54812BEUB	#1 AWG	175/24	¼	1.40 (35.6)	0.67 (17.0)	0.11 (2.8)	0.47 (11.9)	0.25 (6.4)	0.75 (19.1)	37	
54858BEUB	#1 AWG	#2 Weld	⅝	1.63 (41.4)	0.67 (17.0)	0.11 (2.8)	0.47 (11.9)	0.38 (9.7)	0.88 (22.4)	37	
54857BEUB0616	#1 AWG		¾	1.98 (50.3)	0.67 (17.0)	0.11 (2.8)	0.47 (11.9)	0.38 (9.7)	1.00 (25.4)	37	
54857BEUB	#1 AWG		½	3.00 (76.2)	0.88 (22.4)	0.11 (2.8)	0.47 (11.9)	0.50 (12.7)	1.75 (44.5)	37	
54859BEUB0416	1/0 AWG	1 AWG 225/24	¼	1.88 (47.8)	0.75 (19.1)	0.13 (3.3)	0.52 (13.2)	0.38 (9.7)	1.00 (25.4)	42	Pink
54859BEUB0416PH	1/0 AWG		¼	1.88 (47.8)	0.75 (19.1)	0.13 (3.3)	0.52 (13.2)	0.38 (9.7)	1.00 (25.4)	42	
54859BEUB	1/0 AWG		¼	1.19 (30.2)	0.75 (19.1)	0.13 (3.3)	0.52 (13.2)	0.25 (6.4)	0.63 (16.0)	42	
54813BEUB	1/0 AWG		¼	1.38 (35.1)	0.75 (19.1)	0.13 (3.3)	0.52 (13.2)	0.25 (6.4)	0.75 (19.1)	42	
54860BEUB	1/0 AWG		⅝	1.63 (41.4)	0.75 (19.1)	0.13 (3.3)	0.52 (13.2)	0.38 (9.7)	0.88 (22.4)	42	
54860BEUB0616	1/0 AWG		¾	1.98 (50.3)	0.75 (19.1)	0.13 (3.3)	0.52 (13.2)	0.38 (9.7)	1.00 (25.4)	42	
54860BEUB0828	1/0 AWG		½	3.00 (76.2)	0.75 (19.1)	0.13 (3.3)	0.52 (13.2)	0.38 (9.7)	1.75 (44.5)	42	
54814BEUB	2/0 AWG	1/0 AWG 275/24	¼	1.25 (31.8)	0.83 (21.1)	0.13 (3.3)	0.57 (14.5)	0.25 (6.4)	0.63 (16.0)	45	Black
54814BEUB0412	2/0 AWG	1/0 Weld	¼	1.31 (33.3)	0.81 (20.6)	0.13 (3.3)	0.57 (14.5)	0.25 (6.4)	0.75 (19.1)	45	
54862BEUB0616	2/0 AWG		¾	1.81 (46.0)	0.83 (21.1)	0.13 (3.3)	0.57 (14.5)	0.38 (9.7)	1.00 (25.4)	45	
54862BEUB0616PH	2/0 AWG		¾	1.81 (46.0)	0.83 (21.1)	0.13 (3.3)	0.57 (14.5)	0.38 (9.7)	1.00 (25.4)	45	
54862BEUB	2/0 AWG		½	2.81 (71.4)	0.83 (21.1)	0.13 (3.3)	0.57 (14.5)	0.50 (12.7)	0.75 (19.1)	45	

Diagrams

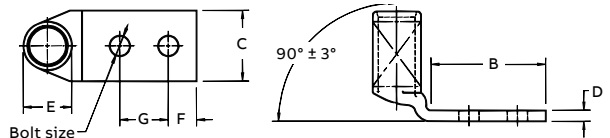

* For installations from 16 kV up to 35 kV, consult shielded cable manufacturers for stress relief and insulation requirements. Call your regional sales office for sizes not listed. For tool and die selection charts, see the section E31-E48 of the Tools, Dies and Kits catalogue.

Compression connectors for copper conductors



Peep holes available – Add suffix PH

Material – High-conductivity wrought copper

Finish – Electro tin plated



Two-hole lugs – 90° Long barrel certified to 600 V and recommended up to 35 kV* (continued)

Cat no.	Code cable	Wire size		Dimensions in. (mm)							Die code	Colour code
		Flex cable classes G, H, I, K, M	Bolt size	B	C	D	E	F	G			
54815BEUB	3/0 AWG	2/0 AWG	¼	1.45 (36.8)	0.92 (23.4)	0.13 (3.3)	0.63 (16.0)	0.25 (6.4)	0.75 (19.1)	50	Orange	
54816BEUB	3/0 AWG	325/24	⅜	1.63 (41.4)	0.92 (23.4)	0.13 (3.3)	0.63 (16.0)	0.38 (9.7)	1.00 (25.4)	50		
54864BEUB	3/0 AWG	2/0 Weld	½	3.00 (76.2)	0.94 (23.9)	0.13 (3.3)	0.63 (16.0)	0.50 (12.7)	1.75 (44.5)	50		
54817BEUB	4/0 AWG	3/0 AWG	¼	1.38 (35.1)	1.03 (33.0)	0.14 (3.6)	0.70 (17.8)	0.25 (6.4)	0.75 (19.1)	54	Purple	
54818BEUB	4/0 AWG	450/24	⅜	2.63 (66.8)	1.03 (33.0)	0.14 (3.6)	0.70 (17.8)	0.38 (9.7)	1.75 (44.5)	54		
54818BEUB0616	4/0 AWG	3/0 Weld	⅜	1.81 (46.0)	1.03 (33.0)	0.14 (3.6)	0.70 (17.8)	0.38 (9.7)	1.00 (25.4)	54		
54818BEUB0616PH	4/0 AWG		⅜	1.88 (47.8)	1.03 (33.0)	0.14 (3.6)	0.70 (17.8)	0.38 (9.7)	1.00 (25.4)	54		
54866BEUB	4/0 AWG		½	3.00 (76.2)	1.03 (33.0)	0.14 (3.6)	0.70 (17.8)	0.50 (12.7)	1.75 (44.5)	54		
54868BEUB0616	250 kcmil	4/0 AWG	⅜	1.93 (49.0)	1.13 (28.7)	0.14 (3.6)	0.77 (19.6)	0.38 (9.7)	1.00 (25.4)	62	Yellow	
54868BEUB0616PH	250 kcmil	550/24	⅜	1.93 (49.0)	1.13 (28.7)	0.14 (3.6)	0.77 (19.6)	0.38 (9.7)	1.00 (25.4)	62		
54868BEUB	250 kcmil	4/0 Weld	½	3.00 (76.2)	1.13 (28.7)	0.14 (3.6)	0.77 (19.6)	0.50 (12.7)	1.75 (44.5)	62		
54819BEUB	300 kcmil	250 kcmil	⅜	2.80 (71.1)	1.25 (31.8)	0.15 (3.8)	0.85 (21.6)	0.38 (9.7)	1.00 (25.4)	66	White	
54870BEUB	300 kcmil	650/24 = 262 kcmil	2	3.00 (76.2)	1.25 (31.8)	0.15 (3.8)	0.85 (21.6)	0.50 (21.6)	1.75 (44.5)	66		
54820BEUB	350 kcmil	650/24	¼	1.93 (49.0)	1.36 (34.5)	0.18 (4.6)	0.93 (23.6)	0.25 (6.4)	0.75 (19.1)	71	Red	
54872BEUB0616	350 kcmil	262 kcmil	⅜	1.93 (49.0)	1.36 (34.5)	0.18 (4.6)	0.93 (23.6)	0.38 (9.7)	1.00 (25.4)	71		
54872BEUB0616PH	350 kcmil		⅜	1.93 (49.0)	1.36 (34.5)	0.18 (4.6)	0.93 (23.6)	0.38 (9.7)	1.00 (25.4)	71		
54872BEUB	350 kcmil		½	3.00 (76.2)	1.36 (34.5)	0.18 (4.6)	0.93 (23.6)	0.50 (21.6)	1.75 (44.5)	71		
54822BEUB	400 kcmil	775/24	¼	1.93 (49.0)	1.41 (35.8)	0.17 (4.3)	0.96 (24.4)	0.25 (6.4)	0.75 (19.1)	76	Blue	
54821BEUB	400 kcmil	313 kcmil	⅜	1.93 (49.0)	1.41 (35.8)	0.17 (4.3)	0.96 (24.4)	0.38 (9.7)	1.00 (25.4)	76		
54874BEUB	400 kcmil		½	3.00 (76.2)	1.41 (35.8)	0.17 (4.3)	0.96 (24.4)	0.50 (21.6)	1.75 (44.5)	76		
54823BEUB	500 kcmil	400 kcmil	¼	1.94 (49.3)	1.61 (40.9)	0.22 (5.6)	1.10 (27.9)	0.25 (6.4)	0.75 (19.1)	87	Brown	
54823BEUB0616	500 kcmil	925/24	⅜	1.93 (49.0)	1.61 (40.9)	0.22 (5.6)	1.10 (27.9)	0.38 (9.7)	1.00 (25.4)	87		
54876BEUB0616PH	500 kcmil	350/373 kcmil	⅜	1.93 (49.0)	1.61 (40.9)	0.22 (5.6)	1.10 (27.9)	0.38 (9.7)	1.00 (25.4)	87		
54876BEUB	500 kcmil		½	3.00 (76.2)	1.61 (40.9)	0.22 (5.6)	1.10 (27.9)	0.50 (21.6)	1.75 (44.5)	87		
54824BEUB	600 kcmil	1,110/24,	⅜	2.80 (71.1)	1.75 (44.5)	0.24 (6.1)	1.20 (30.5)	0.38 (9.7)	1.00 (25.4)	94	Green	
54878BEUB	600 kcmil	444 kcmil	½	3.00 (76.2)	1.75 (44.5)	0.24 (6.1)	1.20 (30.5)	0.50 (21.6)	1.75 (44.5)	94		
54880BEUB0616	750 kcmil	1,325/24	⅜	2.06 (52.3)	1.94 (6.9)	0.27 (6.9)	1.33 (33.8)	0.50 (21.6)	1.00 (25.4)	106	Black	
54880BEUB0616PH	750 kcmil	535 kcmil	⅜	2.06 (52.3)	1.94 (6.9)	0.27 (6.9)	1.33 (33.8)	0.50 (21.6)	1.00 (25.4)	106		
54880BEUB	750 kcmil		½	3.00 (76.2)	1.94 (6.9)	0.27 (6.9)	1.33 (33.8)	0.50 (21.6)	1.75 (44.5)	106		
58884BEUB	–	1,600/24, 646 kcmil	½	3.00 (76.2)	1.94 (6.9)	0.27 (6.9)	1.33 (33.8)	0.50 (21.6)	1.75 (44.5)	106		
58826BEUB	900 kcmil	1,925/24	½	3.00 (76.2)	2.18 (7.9)	0.31 (7.9)	1.50 (38.1)	0.50 (21.6)	1.75 (44.5)	115	Yellow	
		750/777 kcmil										
54826BEUB	1,000 kcmil	–	⅜	2.80 (71.1)	2.27 (7.6)	0.30 (7.6)	1.55 (39.4)	0.38 (9.7)	1.00 (25.4)	125	–	
54882BEUB	1,000 kcmil		½	3.00 (76.2)	2.27 (7.6)	0.30 (7.6)	1.55 (39.4)	0.50 (21.6)	1.75 (44.5)	125		

Diagrams

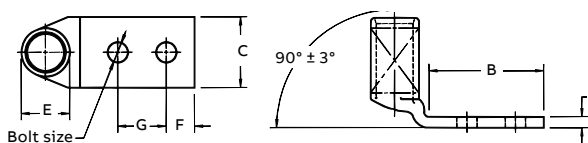

* For installations from 16 kV up to 35 kV, consult shielded cable manufacturers for stress relief and insulation requirements. Call your regional sales office for sizes not listed. For tool and die selection charts, see the section E31-E48 of the Tools, Dies and Kits catalogue.

Compression connectors for copper conductors

Narrow-tongue lugs – Ideal for confined-space terminations



To meet increasing demand for smaller components in today's panels and switchgear, ABB has expanded its line of Color-Keyed narrow-tongue lugs to include two-hole and angled lugs. These improved lugs have been precision engineered for consistency in width the entire length of the connector, from barrel to tongue, ensuring a reliable fit in confined-space applications.

- Narrow-width tongue and barrel, engineered for dimensional consistency the entire length of the lug
- Perfect for connections in limited-space applications
- High-conductivity copper construction
- Electrolytically tin-plated finish resists corrosion
- ABB Color-Keyed marking system makes connections and verification easy
- Double-chamfered barrel eases insertion of wire

Technical specifications

- Certified rating: 600 V
- Recommended rating: Up to 35 kV^Y
- Material: 99% pure high-conductivity seamless wrought copper
- Finish: Electro tin plated
- Standards: UL listed, CSA certified and RoHS compliant



Ideal for use in:

- Panels
- Switchgear
- Molded-case circuit breakers
- Motor starters
- Other limited-space OEM applications

Now available in:

- One-hole
- Two-hole
- Straight
- 45° angled
- 90° angled

^Y For installations from 16 kV up to 35 kV, consult shielded cable manufacturers for stress relief and insulation requirements.

Compression connectors for copper conductors



Narrow-tongue copper lugs – One-hole, standard barrel certified to 600 V and recommended up to 35 kV*

Cat no.	Code cable	Flex cable classes G, H, I, K, M	Bolt size	Wire size						Dimensions in. (mm)			Die code	Colour code
				A	B	C	D	E	F					
54138NT	#4 AWG	#5 AWG – 91/24	#10	1.31 (33.3)	0.56 (14.2)	0.37 (9.4)	0.10 (2.5)	0.37 (9.4)	0.25 (6.4)	29	Grey			
54107NT	#2–3 AWG	#3 AWG – 125/24	¼	1.50 (38.1)	0.65 (16.5)	0.41 (10.4)	0.07 (1.8)	0.41 (10.4)	0.25 (6.4)	33	Brown			
54108NT	#1 AWG	#2 AWG, 150, 175/24	¼	1.50 (38.1)	0.65 (16.5)	0.47 (11.9)	0.11 (2.8)	0.47 (11.9)	0.25 (6.4)	37	Green			
54152NT	1/0 AWG	#1 AWG – 225/24	¼	1.60 (40.6)	0.65 (16.5)	0.52 (13.2)	0.13 (3.3)	0.52 (13.2)	0.25 (6.4)	42	Pink			
54157NT	2/0 AWG	1/0 AWG – 275/24	¼	1.60 (40.6)	0.65 (16.5)	0.57 (14.5)	0.13 (3.3)	0.57 (14.5)	0.25 (6.4)	45	Black			
54162NT	3/0 AWG	2/0 AWG – 325/24	¼	1.68 (42.7)	0.65 (16.5)	0.63 (16.0)	0.13 (3.3)	0.63 (16.0)	0.25 (6.4)	50	Orange			
54167NT	4/0 AWG	3/0 AWG – 450/24	¼	1.90 (48.3)	0.65 (16.5)	0.70 (17.8)	0.14 (3.6)	0.70 (17.8)	0.25 (6.4)	54	Purple			
54172NT	250 kcmil	4/0 AWG – 550/24	¼	2.00 (50.8)	0.65 (16.5)	0.77 (19.6)	0.14 (3.6)	0.77 (19.6)	0.25 (6.4)	62	Yellow			
54178NT04	300 kcmil	650/24	¼	2.33 (59.2)	0.88 (22.4)	0.85 (21.6)	0.15 (3.8)	0.85 (21.6)	0.25 (6.4)	66	White			
54115NT	350 kcmil	650/24	½	2.75 (69.9)	1.25 (31.8)	0.93 (23.6)	0.18 (4.6)	0.93 (23.6)	0.50 (12.7)	71H	Red			
54115NT06	350 kcmil	650/24	¾	2.50 (63.5)	1.00 (25.4)	0.93 (23.6)	0.18 (4.6)	0.93 (23.6)	0.38 (16.0)	71H	Red			
54118NT	500 kcmil	925/24	½	3.25 (82.6)	1.25 (31.8)	1.10 (27.9)	0.22 (5.6)	1.10 (27.9)	0.50 (12.7)	87	Brown			
54123NT08	750 kcmil	1,325/24	½	3.48 (88.4)	1.25 (31.8)	1.33 (33.8)	0.27 (6.9)	1.33 (33.8)	0.50 (12.7)	106H	Black			
54123NT	750 kcmil	1,325/24	¾	3.80 (96.5)	1.58 (40.1)	1.33 (33.8)	0.27 (6.9)	1.33 (33.8)	0.63 (16.0)	106H	Black			

Diagrams

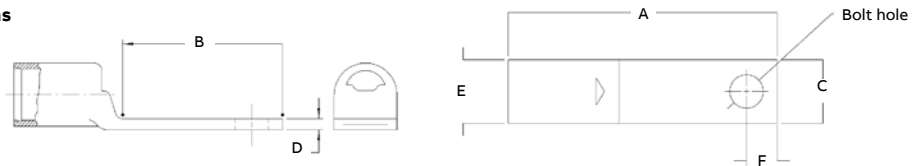

* For installations from 16 kV up to 35 kV, consult shielded cable manufacturers for stress relief and insulation requirements.

* Special lugs may have other catalogue number constructions. Please contact technical services.

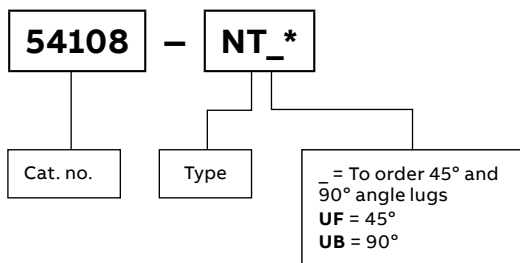

Ordering information

Other options include silver plating (add SP to catalogue number), blind end (add BE to catalogue number) and peep holes (add PH to catalogue number).

Catalogue no. example:

54108NTUB is a 90° angled one-hole narrow-tongue lug for #1 AWG.

Compression connectors for copper conductors



Narrow-tongue copper lugs – Two-hole, standard barrel certified to 600 V and recommended up to 35 kV*

Cat no.	Wire size			Dimensions in. (mm)								Die code	Colour code
	Code cable	Flex cable classes G, H, I, K, M	Bolt size	A	B	C	D	E	F	H			
54206NT0310	#4 AWG	#5 AWG – 91/24	#10	1.88 (47.8)	1.13 (28.7)	0.37 (9.4)	0.10 (2.5)	0.37 (9.4)	0.25 (6.4)	0.63 (16.0)	29	Grey	
54207NT	#2–3 AWG	#3 AWG – 125/24	¼	2.04 (61.0)	1.19 (30.2)	0.41 (10.4)	0.11 (2.8)	0.41 (10.4)	0.25 (6.4)	0.63 (16.0)	33	Brown	
54207NT0412	#2–3 AWG	#3 AWG – 125/24	¼	2.16 (54.9)	1.31 (33.3)	0.41 (10.4)	0.11 (2.8)	0.41 (10.4)	0.25 (6.4)	0.75 (19.1)	33	Brown	
54207NT0416	#2–3 AWG	#3 AWG – 125/24	¼	2.41 (61.2)	1.56 (39.6)	0.41 (10.4)	0.11 (2.8)	0.41 (10.4)	0.25 (6.4)	1.00 (25.4)	33	Brown	
54208NT	#1 AWG	#2 AWG – 150, 175/24	¼	2.40 (61.0)	1.19 (30.2)	0.47 (11.9)	0.11 (2.8)	0.47 (11.9)	0.25 (6.4)	0.63 (16.0)	37	Green	
54208NT0516	#1 AWG	#2 AWG – 150, 175/24	5/16	2.63 (66.8)	1.78 (45.2)	0.47 (11.9)	0.11 (2.8)	0.47 (11.9)	0.38 (9.7)	1.00 (25.4)	37	Green	
54255NT	1/0 AWG	#1 AWG – 225/24	5/16	2.61 (66.3)	1.66 (42.2)	0.52 (13.2)	0.14 (3.6)	0.52 (13.2)	0.38 (9.7)	0.88 (22.4)	42	Pink	
54261NT	2/0 AWG	1/0 AWG – 275/24	3/8	2.66 (67.6)	1.66 (42.2)	0.57 (14.5)	0.14 (3.6)	0.52 (13.2)	0.38 (9.7)	0.88 (22.4)	45	Black	
54210NT	2/0 AWG	1/0 AWG – 275/24	3/8	2.82 (71.6)	1.82 (46.2)	0.57 (14.5)	0.14 (3.6)	0.52 (13.2)	0.38 (9.7)	1.00 (25.4)	45	Black	
54266NT	3/0 AWG	2/0 AWG – 325/24	3/8	2.88 (73.2)	1.78 (45.2)	0.63 (16.0)	0.13 (3.3)	0.63 (16.0)	0.38 (9.7)	1.00 (25.4)	50	Orange	
54211NT	3/0 AWG	2/0 AWG – 325/24	3/8	2.92 (74.2)	1.82 (46.2)	0.63 (16.0)	0.13 (3.3)	0.63 (16.0)	0.38 (9.7)	1.00 (25.4)	50	Orange	
54212NT	4/0 AWG	3/0 AWG – 450/24	3/8	3.07 (94.0)	1.82 (46.2)	0.70 (17.8)	0.14 (3.6)	0.70 (17.8)	0.38 (9.7)	1.00 (25.4)	54	Purple	
54213NT	250 kcmil	4/0 AWG – 550/24	3/8	3.17 (80.5)	1.82 (46.2)	0.77 (19.6)	0.14 (3.6)	0.77 (19.6)	0.38 (9.7)	1.00 (25.4)	62	Yellow	
54275NT	250 kcmil	4/0 AWG – 550/24	½	4.16 (105.7)	2.81 (71.4)	0.77 (19.6)	0.14 (3.6)	0.77 (19.6)	0.50 (12.7)	1.75 (44.5)	62	Yellow	
54282NT	350 kcmil	650/24	½	4.36 (110.7)	2.81 (71.4)	0.93 (23.6)	0.18 (4.6)	0.93 (23.6)	0.50 (12.7)	1.75 (44.5)	71H	Red	
54218NT	500 kcmil	925/24	3/8	4.57 (116.1)	2.57 (65.3)	1.10 (27.9)	0.22 (5.6)	1.10 (27.9)	0.38 (9.7)	1.75 (44.5)	87	Brown	
54286NT	500 kcmil	925/24	½	4.81 (122.2)	2.81 (71.4)	1.10 (27.9)	0.22 (5.6)	1.10 (27.9)	0.50 (12.7)	1.75 (44.5)	87	Brown	
54878BENTPH	600 kcmil	1,100/24	½	5.83 (148.1)	3.00 (76.2)	1.20 (30.5)	0.24 (6.1)	1.20 (30.5)	0.50 (12.7)	1.75 (44.5)	94	Green	
54223NT0628	750 kcmil	1,325/24	3/8	4.79 (121.7)	2.57 (65.3)	1.33 (33.8)	0.27 (6.9)	1.33 (33.8)	0.38 (9.7)	1.75 (44.5)	106H	Black	
54223NT	750 kcmil	1,325/24	½	5.04 (137.2)	2.81 (71.4)	1.33 (33.8)	0.27 (6.9)	1.33 (33.8)	0.50 (12.7)	1.75 (44.5)	106H	Black	
58884BENTPH	-	1,600/24	½	6.16 (156.5)	3.00 (76.2)	1.33 (33.8)	0.24 (6.1)	1.20 (30.5)	0.50 (12.7)	1.75 (44.5)	106H	Black	

Diagrams

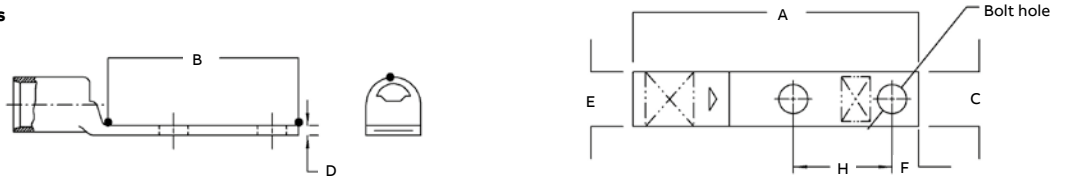

Catalogue numbers 54878BENTPH and 58884BENTPH include peep holes.

* For installations from 16 kV up to 35 kV, consult shielded cable manufacturers for stress relief and insulation requirements.

* Special lugs may have other catalogue number constructions. Please contact technical services.

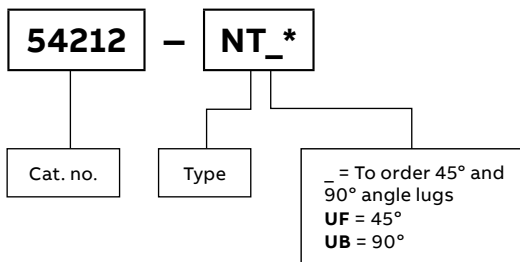

Ordering information

Other options include silver plating (add SP to catalogue number), blind end (add BE to catalogue number) and peep holes (add PH to catalogue number).

Catalogue no. example:

54212NTUB is a 90° angled one-hole narrow-tongue lug for #1 AWG.

Compression connectors for copper conductors

These Color-Keyed connectors are recommended for up to 15 kV applications. Installed with standard ABB 14 and 15-ton compression tools with special rounding dies, the compression forms the connector and conductor into a solid mass to provide an optimum electrical bond between connector and conductor. The rounding die overlapped compressions provide a smooth round surface. This combined with the tapered barrel ends, addresses the control for potentially damaging electrical stresses of high voltages.



Copper one-hole lugs – Certified to 600 V and recommended up to 15 kV

Cat no.	Cable size**		Dimensions in. (mm)						Installing tools 14 and 15 tons*		
	Code cable	Stud size (in.)	A	B	C	D	E	F	Die set cat. no.	Strip length (in.)	Colour code
54440	#4 AWG	3/8	2.08 (71.1)	0.81 (20.6)	0.58 (14.7)	0.08 (2.0)	0.38 (9.7)	0.50 (12.7)	15CA29R	1 ⁷ / ₁₆	Grey
54443	#2 AWG	3/8	2.25 (57.2)	0.81 (20.6)	0.66 (16.8)	0.09 (2.3)	0.38 (9.7)	0.50 (12.7)	15CA33R	1 ⁷ / ₁₆	Brown
54448	#1 AWG	3/8	2.36 (59.9)	0.81 (20.6)	0.69 (17.5)	0.10 (2.5)	0.38 (9.7)	0.50 (12.7)	15CA37R	1 ¹⁸ / ₃₂	Green
54409	1/0 AWG	3/8	2.38 (60.5)	0.81 (20.6)	0.75 (19.1)	0.12 (3.0)	0.38 (9.7)	0.50 (12.7)	15CA42R	1 ⁹ / ₁₆	Pink
54460	2/0 AWG	1/2	2.73 (69.3)	1.06 (40.6)	0.83 (21.1)	0.12 (3.0)	0.50 (12.7)	0.50 (12.7)	15CA45R	1 ⁹ / ₁₆	Black
54465	3/0 AWG	1/2	2.81 (71.4)	1.06 (40.6)	0.94 (23.9)	0.12 (3.0)	0.50 (12.7)	0.50 (12.7)	15CA49R	1 ³ / ₄	Orange
54470	4/0 AWG	1/2	2.78 (70.6)	1.06 (40.6)	1.00 (25.4)	0.13 (3.3)	0.50 (12.7)	0.50 (12.7)	15CA54R	1 ¹³ / ₁₆	Purple
54413	250 kcmil	1/2	3.19 (81.0)	1.06 (40.6)	1.07 (43.2)	0.14 (3.6)	0.50 (12.7)	0.50 (12.7)	15CA60R	2 ¹ / ₃₂	Ruby

Diagrams

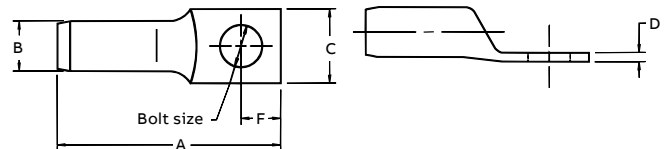

**Cable size: Concentric (code) and compact strandings

*Cat. no. TB15500 die adaptor required for TBM151

For tool and die selection charts, see the section E31-E48 of the Tools, Dies and Kits catalogue.

Compression connectors for copper conductors

These Color-Keyed connectors are recommended for up to 15 kV applications. Installed with standard ABB 14 and 15-ton compression tools with special rounding dies, the compression forms the connector and conductor into a solid mass to provide an optimum electrical bond between connector and conductor. The rounding die overlapped compressions provide a smooth round surface. This combined with the tapered barrel ends, addresses the control for potentially damaging electrical stresses of high voltages.



Copper two-hole lugs – Certified to 600 V and recommended up to 15 kV

Cat no.	Cable size**		Dimensions in. (mm)							Installing tools 14 and 15 tons*		
	Code cable size (in.)	Stud (in.)	A	B	C	D	E	F	G	Die set cat. no.	Strip length (in.)	Colour code
54475	1/0 AWG	3/8	3.56 (90.4)	0.53 (13.5)	0.77 (19.6)	0.12 (3.0)	0.38 (9.7)	0.38 (9.7)	1.00 (25.4)	15CA42R	1 1/8	Pink
54476	2/0 AWG	1/2	4.67 (118.6)	0.56 (14.2)	0.83 (21.1)	0.12 (3.0)	0.50 (12.7)	0.50 (12.7)	1.75 (44.5)	15CA45R	1 1/8	Black
54478	3/0 AWG	1/2	4.75 (120.7)	0.63 (16.0)	0.94 (23.9)	0.12 (3.0)	0.50 (12.7)	0.50 (12.7)	1.75 (44.5)	15CA49R	1 3/4	Orange
54479	4/0 AWG	1/2	4.64 (117.9)	0.69 (17.3)	1.00 (25.4)	0.13 (3.3)	0.50 (12.7)	0.50 (12.7)	1.75 (44.5)	15CA54R	1 3/16	Purple
54480	250 kcmil	1/2	5.17 (131.3)	0.75 (19.1)	1.08 (45.7)	0.14 (3.6)	0.50 (12.7)	0.50 (12.7)	1.75 (44.5)	15CA60R	2 1/32	Ruby
54481	300 kcmil	1/2	5.16 (131.1)	0.81 (20.6)	1.19 (30.2)	0.16 (4.1)	0.50 (12.7)	0.50 (12.7)	1.75 (44.5)	15CA66R	2 9/32	White
54482	350 kcmil	1/2	5.35 (135.9)	0.88 (22.1)	1.29 (32.8)	0.19 (4.8)	0.50 (12.7)	0.50 (12.7)	1.75 (44.5)	15CA71R	2 13/32	Red
54483	400 kcmil	1/2	5.35 (135.9)	0.92 (23.4)	1.36 (34.5)	0.18 (4.6)	0.50 (12.7)	0.50 (12.7)	1.75 (44.5)	15CA76R	2 13/32	Blue
54484	500 kcmil	1/2	5.60 (142.2)	1.06 (40.6)	1.54 (39.1)	0.23 (5.8)	0.50 (12.7)	0.50 (12.7)	1.75 (44.5)	15CA87R	2 13/32	Brown
54485***	600 kcmil	1/2	5.83 (148.1)	1.17 (29.7)	1.70 (43.2)	0.24 (6.1)	0.50 (12.7)	0.50 (12.7)	1.75 (44.5)	15CA84R	2 9/16	Green
54487***	750 kcmil	1/2	6.13 (155.7)	1.11 (27.9)	1.89 (48.0)	0.27 (6.9)	0.50 (12.7)	0.50 (12.7)	1.75 (44.5)	15CA106R	2 3/4	Black
54490	1,000 kcmil	1/2	6.60 (167.6)	1.50 (38.1)	2.18 (55.4)	0.31 (7.9)	0.50 (12.7)	0.50 (12.7)	1.75 (44.5)	15C125R•	2 29/32	-

Diagrams

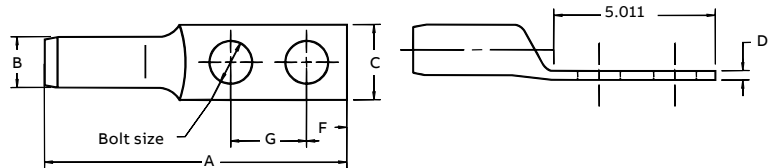

* Cat. no. TB15500 die adaptor required for TBM151.

• No adaptor required – TBM151 only.

** Cable size: Concentric (code) and compact strandings.

14-Ton tool UL listing limited to 1/0 AWG and 500 kcmil cable sizes.

*** 15-Ton tool only for 500 kcmil and over.

For tool and die selection charts, see the section E31-E48 of the Tools, Dies and Kits catalogue.

Compression connectors for copper conductors



Bell-ended lugs – Standard barrel certified to 600 V and recommended up to 35 kV*

Cat. no.	Wire size (AWG or kcmil)*			Classes					Bolt size (in.)	Dimensions in. (mm)					Die code	Colour code
	Code cable	Navy	Flex	G	H	I	K	M		A	B	C	D	F		
54104BS	8	23	37/24	8	8	-	8	8	#10	1.06 (40.6)	0.46 (11.7)	0.40 (10.2)	0.07 (1.8)	0.21 (5.3)	21	Red
54105BS	6	30	61/24	5	5	5	5	5	1/4	1.18 (30.0)	0.56 (14.2)	0.43 (10.9)	0.10 (2.5)	0.25 (6.4)	24	Blue
54106BS	4	40-50	91/24	5	5	5	5	5	1/4	1.28 (32.5)	0.56 (14.2)	0.56 (14.2)	0.10 (2.5)	0.25 (6.4)	29	Grey
54139BS	3-4	40-50	91/24	4	4	4	4	4	5/16	1.43 (36.3)	0.78 (19.8)	0.59 (19.8)	0.07 (1.8)	0.34 (8.6)	29	Grey
54142BS	2	60	125/24	3	3	3	3	3	5/16	1.53 (38.9)	0.71 (18.0)	0.65 (16.5)	0.07 (1.8)	0.34 (8.6)	33	Brown
54147BS	1	75	150, 175/24	2	2	2	2	2	5/16	1.91 (48.5)	0.71 (18.0)	0.67 (17.0)	0.12 (3.0)	0.38 (9.7)	37	Green
54153BS	1/0	100	225/24	1	1	1	1	1	5/16	1.63 (41.4)	0.71 (18.0)	0.75 (19.1)	0.14 (3.6)	0.38 (9.7)	42	Pink
54110BS	2/0	125	275/24	1/0	1/0	1/0	1/0	1/0	3/8	1.88 (47.8)	0.81 (20.6)	0.81 (20.6)	0.14 (3.6)	0.38 (9.7)	45	Black
54165BS	3/0	150	325/24	2/0	2/0	2/0	2/0	2/0	1/2	2.21 (56.1)	1.06 (40.6)	0.93 (23.6)	0.14 (3.6)	0.50 (12.7)	50	Orange
54170BS	4/0	200	450/24	3/0	3/0	3/0	3/0	3/0	1/2	2.31 (58.7)	1.06 (40.6)	1.03 (33.0)	0.15 (3.8)	0.50 (12.7)	54	Purple
58165BS	250	-	550/24	4/0	4/0	4/0	4/0	4/0	1/2	2.46 (62.5)	1.12 (28.4)	1.25 (31.8)	0.18 (4.6)	0.50 (12.7)	62	Yellow
54114BS	300	300	650/24	250	250	250	250	-	1/2	2.46 (62.5)	1.12 (28.4)	1.25 (31.8)	0.18 (4.6)	0.50 (12.7)	66	White
5411440BS	300	300	650/24	250	250	250	250	-	1/2	2.38 (60.5)	1.12 (28.4)	1.25 (31.8)	0.18 (4.6)	0.50 (12.7)	66	White
54115260BS	350	350	650/24	-	-	250	250	250	1/2	2.63 (66.8)	1.18 (30.0)	1.38 (35.1)	0.20 (5.1)	0.56 (14.2)	66	White
54185BS	400	400	775/24	300	300	300	300	300	5/8	3.43 (87.1)	1.68 (42.7)	1.40 (35.6)	0.21 (5.3)	0.81 (20.6)	76	Blue
58177BS	500	-	925/24	400	400	400	400	400	5/8	3.00 (76.2)	1.31 (33.3)	1.63 (41.4)	0.25 (6.4)	0.81 (20.6)	80	-
58180BS	600	-	1,100/24	-	-	450	450	450	5/8	3.63 (92.2)	1.68 (42.7)	1.78 (45.2)	0.26 (6.6)	0.81 (20.6)	94	Green
54122BS	700	-	1,325/24	500	500	500	500	500	5/8	3.63 (92.2)	1.68 (42.7)	1.78 (45.2)	0.28 (7.1)	0.81 (20.6)	99	Pink
54123BS	750	-	-	600	-	-	-	550	5/8	3.63 (92.2)	1.68 (42.7)	1.93 (49.0)	0.31 (7.9)	0.81 (20.6)	106	Black
54124BS	800	800	-	-	-	-	-	600	5/8	3.81 (96.8)	1.68 (42.7)	2.00 (50.8)	0.31 (7.9)	0.63 (16.0)	107	Orange
54126BS	900	-	1,925/24	-	-	750	-	-	5/8	4.12 (104.6)	1.81 (46.0)	2.18 (55.4)	0.37 (9.4)	0.88 (22.4)	115	Yellow

Diagrams

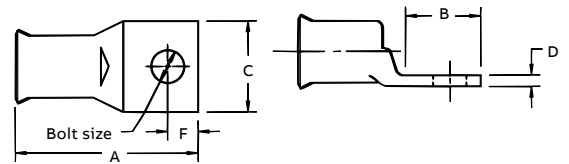

* For installations from 16 kV up to 35 kV, consult shielded cable manufacturers for stress relief and insulation requirements.

* Stranding will differ per class.

For tool and die selection charts, see the section E31-E48 of the Tools, Dies and Kits catalogue.

Compression connectors for copper conductors



Bell-ended lugs – Standard barrel certified to 600 V and recommended up to 35 kV*

Cat. no.	Wire size (AWG or kcmil)*			Classes					Bolt size (in.)	Dimensions in. (mm)							Die G code	Colour code
	Code cable	Navy	Flex	G	H	I	K	M		A	B	C	D	E	F			
54850BEBS	8	23	8	8	8	-	8	-	¼	2.19 (55.6)	1.88 (47.8)	0.42 (10.7)	0.07 (1.8)	0.26 (6.6)	0.25 (6.4)	0.63 (16.0)	21	Red
54851BEBS	8	23	8	8	8	-	8	-	¼	2.31 (58.7)	1.59 (40.7)	0.47 (11.9)	0.06 (1.5)	0.26 (6.6)	0.25 (6.4)	0.75 (19.1)	21	
54851BE0616BS	8	23	8	8	8	-	8	-	⅜	3.00 (76.2)	2.10 (53.3)	0.56 (14.2)	0.06 (1.5)	0.26 (6.6)	0.38 (9.7)	1.00 (25.4)	21	
54852BE0616BS	6	30	6	5	5	5	5	-	⅜	2.93 (74.4)	1.93 (49.0)	0.59 (15.0)	0.06 (1.5)	0.30 (7.6)	0.38 (9.7)	1.00 (25.4)	24	Blue
54852BEBS	6	30	6	5	5	5	5	-	¼	2.28 (57.9)	1.28 (32.5)	0.44 (11.2)	0.08 (2.0)	0.30 (7.6)	0.25 (6.4)	0.63 (16.0)	24	
54852BE0412BS	6	30	6	5	5	5	5	-	¼	2.43 (61.7)	1.43 (36.3)	0.43 (10.9)	0.07 (1.8)	0.30 (7.6)	0.25 (6.4)	0.75 (19.1)	24	
54854BEBS	4-3	40-50	5	5	5	5	5	-	¼	2.31 (58.7)	1.19 (30.2)	0.52 (13.2)	0.10 (2.5)	0.37 (9.4)	0.25 (6.4)	0.63 (16.0)	29	Grey
54854BE0412BS	4-3	40-50	5	5	5	5	5	-	¼	2.31 (58.7)	1.31 (33.3)	0.56 (14.2)	0.09 (2.3)	0.37 (9.4)	0.25 (6.4)	0.75 (19.1)	29	
54854BE0616BS	4-3	40-50	5	5	5	5	5	-	⅜	3.13 (79.5)	1.98 (50.3)	0.59 (15.0)	0.09 (2.3)	0.37 (9.4)	0.38 (9.7)	1.00 (25.4)	29	
54855BE0412BS	2	60	3	3	3	3	3	3	¼	2.63 (66.8)	1.35 (34.3)	0.68 (17.3)	0.11 (2.8)	0.41 (10.4)	0.25 (6.4)	0.75 (19.1)	33	Brown
54855BEBS	2	60	3	3	3	3	3	3	¼	2.43 (61.7)	1.28 (32.5)	0.59 (15.0)	0.11 (2.8)	0.41 (10.4)	0.25 (6.4)	0.63 (16.0)	33	
54856BEBS	2	60	3	3	3	3	3	3	⅜	2.78 (70.6)	1.63 (41.4)	0.59 (15.0)	0.11 (2.8)	0.41 (10.4)	0.38 (9.7)	0.75 (19.1)	33	
54810BE0616BS	2	60	3	3	3	3	3	3	⅜	3.08 (96.5)	1.94 (49.3)	0.59 (15.0)	0.11 (2.8)	0.41 (10.4)	0.38 (9.7)	1.00 (25.4)	33	
54811BEBS	2	60	3	3	3	3	3	3	½	4.28 (108.7)	3.00 (76.2)	0.88 (22.4)	0.09 (2.3)	0.41 (10.4)	0.50 (12.7)	1.75 (44.5)	33	
54809BEBS	1	75	2	2	2	2	2	2	¼	2.88 (73.2)	1.19 (30.2)	0.67 (17.0)	0.11 (2.8)	0.47 (11.9)	0.25 (6.4)	0.63 (16.0)	37	Green
54812BEBS	1	75	2	2	2	2	2	2	¼	2.75 (69.9)	1.40 (35.6)	0.67 (17.0)	0.11 (2.8)	0.47 (11.9)	0.25 (6.4)	0.75 (19.1)	37	
54858BEBS	1	75	2	2	2	2	2	2	⅜	2.97 (75.4)	1.63 (41.4)	0.67 (17.0)	0.11 (2.8)	0.47 (11.9)	0.38 (9.7)	0.88 (22.4)	37	
54857BEBS	1	75	2	2	2	2	2	2	½	4.43 (112.5)	3.00 (76.2)	0.88 (22.4)	0.10 (2.5)	0.47 (11.9)	0.50 (12.7)	1.75 (44.5)	37	

Diagrams

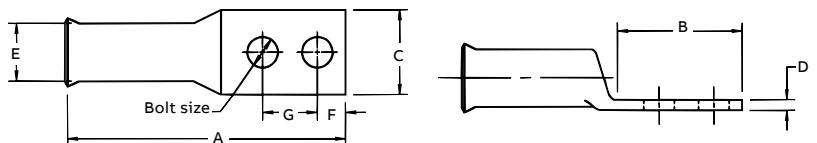

* For installations from 16 kV up to 35 kV, consult shielded cable manufacturers for stress relief and insulation requirements.

* Stranding will differ per class.

For tool and die selection charts, see the section E31-E48 of the Tools, Dies and Kits catalogue.

Compression connectors for copper conductors



Bell-ended lugs – Standard barrel certified to 600 V and recommended up to 35 kV* (continued)

Cat. no.	Wire size (AWG or kcmil)*			Classes						Bolt size (in.)	Dimensions in. (mm)							Die code	Colour code
	Code cable	Navy	Flex	G	H	I	K	M	A		B	C	D	E	F	G			
54859BEBS	1/0	100	1	1	1	1	1	1	1	1/4	2.63 (66.8)	1.19 (30.2)	0.75 (19.1)	0.13 (3.3)	0.52 (13.2)	0.25 (6.4)	0.63 (16.0)	42	Pink
54813BEBS	1/0	100	1	1	1	1	1	1	1	1/4	2.71 (68.8)	1.38 (35.1)	0.75 (19.1)	0.13 (3.3)	0.52 (13.2)	0.25 (6.4)	0.75 (19.1)	42	
54860BEBS	1/0	100	1	1	1	1	1	1	1	5/16	2.97 (75.4)	1.63 (41.4)	0.75 (19.1)	0.13 (3.3)	0.52 (13.2)	0.38 (9.7)	0.88 (22.4)	42	
54860BE0616BS	1/0	100	1	1	1	1	1	1	1	3/8	3.23 (82.0)	1.93 (49.0)	0.75 (19.1)	0.13 (3.3)	0.52 (13.2)	0.38 (9.7)	1.00 (25.4)	42	
54814BEBS	2/0	250	1/0	1/0	1/0	1/0	1/0	1/0	1/0	1/4	2.62 (66.5)	1.25 (31.8)	0.83 (21.1)	0.13 (3.3)	0.57 (14.5)	0.25 (6.4)	0.63 (16.0)	45	Black
54814BE0412BS	2/0	250	1/0	1/0	1/0	1/0	1/0	1/0	1/0	1/4	2.69 (68.3)	1.31 (33.3)	0.81 (20.6)	0.13 (3.3)	0.57 (14.5)	0.25 (6.4)	0.75 (19.1)	45	
54862BE0616BS	2/0	250	1/0	1/0	1/0	1/0	1/0	1/0	1/0	3/8	3.19 (81.0)	1.81 (46.0)	0.83 (21.1)	0.13 (3.3)	0.57 (14.5)	0.38 (9.7)	1.00 (25.4)	45	
54862BEBS	2/0	250	1/0	1/0	1/0	1/0	1/0	1/0	1/0	1/2	2.20 (55.9)	2.81 (71.4)	0.83 (21.1)	0.13 (3.3)	0.57 (14.5)	0.50 (12.7)	1.75 (44.5)	45	
54815BEBS	3/0	150	2/0	2/0	2/0	2/0	2/0	2/0	2/0	1/4	2.89 (73.4)	1.45 (36.8)	0.92 (23.4)	0.13 (3.3)	0.63 (16.0)	0.25 (6.4)	0.75 (19.1)	50	Orange
54816BEBS	3/0	150	2/0	2/0	2/0	2/0	2/0	2/0	2/0	3/8	3.25 (82.6)	1.63 (41.4)	0.92 (23.4)	0.13 (3.3)	0.63 (16.0)	0.38 (9.7)	1.00 (25.4)	50	
54864BEBS	3/0	150	2/0	2/0	2/0	2/0	2/0	2/0	2/0	1/2	4.45 (113.0)	3.00 (76.2)	0.92 (23.4)	0.13 (3.3)	0.63 (16.0)	0.50 (12.7)	1.75 (44.5)	50	
54817BEBS	4/0	200	3/0	3/0	3/0	3/0	3/0	3/0	3/0	1/4	3.15 (80.0)	1.38 (35.1)	1.03 (26.2)	0.14 (3.6)	0.70 (17.8)	0.50 (12.7)	0.75 (19.1)	54	Purple
54818BE0616BS	4/0	200	3/0	3/0	3/0	3/0	3/0	3/0	3/0	3/8	3.35 (85.1)	1.81 (46.0)	1.03 (26.2)	0.14 (3.6)	0.70 (17.8)	0.25 (6.4)	1.00 (25.4)	54	
54818BEBS	4/0	200	3/0	3/0	3/0	3/0	3/0	3/0	3/0	3/8	4.38 (111.3)	2.63 (66.8)	1.03 (26.2)	0.14 (3.6)	0.70 (17.8)	0.38 (9.7)	1.75 (44.5)	54	
54866BEBS	4/0	200	3/0	3/0	3/0	3/0	3/0	3/0	3/0	1/2	4.70 (119.4)	3.00 (76.2)	1.03 (26.2)	0.14 (3.6)	0.70 (17.8)	0.50 (12.7)	1.75 (44.5)	54	
54868BE0616BS	250	-	4/0	4/0	4/0	4/0	4/0	4/0	4/0	3/8	3.83 (97.3)	1.93 (49.0)	1.13 (28.7)	0.14 (3.6)	0.77 (19.6)	0.50 (12.7)	1.00 (25.4)	62	Yellow
54868BEBS	250	-	4/0	4/0	4/0	4/0	4/0	4/0	4/0	1/2	4.92 (125.0)	3.00 (76.2)	1.13 (28.7)	0.14 (3.6)	0.77 (19.6)	0.50 (12.7)	1.75 (44.5)	62	

Diagrams

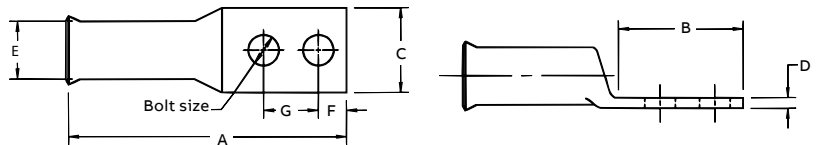

* For installations from 16 kV up to 35 kV, consult shielded cable manufacturers for stress relief and insulation requirements.

* Stranding will differ per class.

For tool and die selection charts, see the section E31-E48 of the Tools, Dies and Kits catalogue.

Compression connectors for copper conductors



Bell-ended lugs – Standard barrel certified to 600 V and recommended up to 35 kV* (continued)

Cat. no.	Wire size (AWG or kcmil)*								Classes	Bolt size (in.)	Dimensions in. (mm)							Die code	Colour code
	Code cable	Navy	Flex	G	H	I	K	M			A	B	C	D	E	F	G		
54819BEBS	300	300	262	250	250	250	250	-	3/8	5.04 (137.2)	2.80 (71.1)	1.25 (31.8)	0.15 (3.8)	0.85 (21.6)	0.50 (12.7)	1.00 (25.4)	66	White	
54870BEBS	300	300	262	250	250	250	250	-	1/2	5.23 (132.8)	3.00 (76.2)	1.25 (31.8)	0.15 (3.8)	0.85 (21.6)	0.50 (12.7)	1.75 (44.5)	66		
54822BEBS	400	400	313	300	300	300	300	-	1/4	4.38 (111.3)	1.93 (49.0)	1.41 (35.8)	0.17 (4.3)	0.96 (24.4)	0.63 (16.0)	0.75 (19.1)	76	Blue	
54821BEBS	400	400	313	300	300	300	300	-	3/8	4.43 (112.5)	1.93 (49.0)	1.41 (35.8)	0.17 (4.3)	0.96 (24.4)	0.63 (16.0)	1.00 (25.4)	76		
54874BEBS	400	400	313	300	300	300	300	-	1/2	5.51 (140.0)	3.00 (76.2)	1.41 (35.8)	0.17 (4.3)	0.96 (24.4)	0.63 (16.0)	1.75 (44.5)	76	Blue	
54823BEBS	500	-	373	400	400	400	400	-	1/4	4.93 (125.2)	1.94 (49.3)	1.61 (40.9)	0.22 (5.6)	1.10 (27.9)	0.50 (12.7)	0.75 (19.1)	87	Brown	
54876BE0616BS	500	-	373	400	400	400	400	-	3/8	5.00 (127.0)	1.93 (49.0)	1.61 (40.9)	0.22 (5.6)	1.10 (27.9)	0.50 (12.7)	1.00 (25.4)	87	Brown	
54876BEBS	500	-	373	400	400	400	400	-	1/2	6.00 (152.4)	3.00 (76.2)	1.61 (40.9)	0.22 (5.6)	1.10 (27.9)	0.50 (12.7)	1.75 (44.5)	87	Brown	
54824BEBS	-	-	444	-	-	450	450	-	3/8	5.70 (144.8)	2.80 (71.1)	1.75 (44.5)	0.24 (6.1)	1.20 (30.5)	0.63 (16.0)	1.00 (25.4)	94	Green	
54878BEBS	-	-	444	-	-	450	450	-	1/2	5.83 (148.1)	3.00 (76.2)	1.75 (44.5)	0.24 (6.1)	1.20 (30.5)	0.63 (16.0)	1.75 (44.5)	94	Green	
54879BEBS	700	-	535	-	-	-	-	-	1/2	6.00 (152.4)	3.00 (76.2)	2.81 (71.4)	0.28 (7.1)	1.25 (31.8)	0.50 (12.7)	1.75 (44.5)	99	Pink	
54880BEBS	700	-	535	500	500	500	500	-	1/2	6.20 (157.5)	3.00 (76.2)	1.94 (49.3)	0.27 (6.9)	1.33 (33.8)	0.63 (16.0)	1.75 (44.5)	106	Black	
58884BEBS	-	-	646	-	-	-	-	-	1/2	6.16 (156.4)	3.00 (76.2)	1.94 (49.3)	0.27 (6.9)	1.33 (33.8)	0.50 (12.7)	1.75 (44.5)	106	Black	
58826BEBS	900	-	777	-	-	750	-	-	3/8	6.49 (164.8)	2.80 (71.1)	2.27 (57.7)	0.30 (7.6)	1.50 (38.1)	0.63 (16.0)	1.00 (25.4)	115	Yellow	

Diagrams

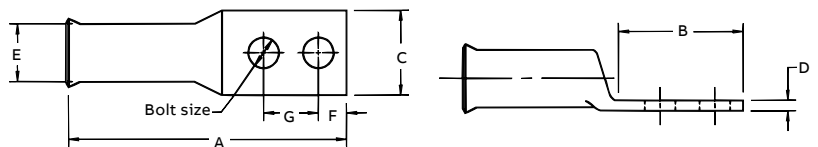

* For installations from 16 kV up to 35 kV, consult shielded cable manufacturers for stress relief and insulation requirements.

* Stranding will differ per class.

For tool and die selection charts, see the section E31-E48 of the Tools, Dies and Kits catalogue.

Compression connectors for copper conductors



Material – High-conductivity wrought copper
Finish – Electro tin plated



Two-barrel lugs – Certified to 600 V and recommended up to 35 kV*

Cat. no.	Wire size (AWG or kcmil)		Hole size (in.)	Fig. no.	Dimensions in. (mm)			Die code	Colour code
	Code cable	Flex			A	W	T		
256-30695-828	#6	61/24	1/4	1	2.94 (74.7)	0.44 (11.2)	0.06 (1.5)	24	Blue
256-30695-1227	#6	61/24	1/4	2	3.38 (85.9)	0.44 (11.2)	0.06 (1.5)	24	Blue

Diagrams

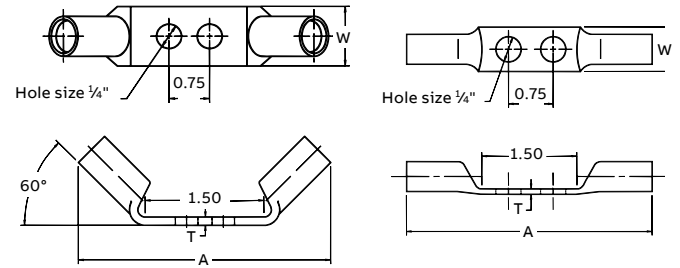

Figure 1

Figure 2

* For installations from 16 kV up to 35 kV, consult shielded cable manufacturers for stress relief and insulation requirements. For tool and die selection charts, see the section E31-E48 of the Tools, Dies and Kits catalogue.

Compression connectors for copper conductors



Material – High-conductivity wrought copper
Finish – Electro tin plated



Cast copper one-hole lugs heavy-duty — certified to 600 V and recommended up to 35 kV*

Cat. no.	Code cable size (AWG or kcmil)	Dimensions in. (mm)					Bolt size (in.)	Die code
		A	B	C	D	F		
53104	8	1.43 (36.3)	0.75 (19.1)	0.50 (12.7)	0.12 (3.0)	0.28 (7.1)	#10	29
53105	6	1.43 (36.3)	0.75 (19.1)	0.50 (12.7)	0.12 (3.0)	0.28 (7.1)	¼	29
53106	4	1.43 (36.3)	0.75 (19.1)	0.50 (12.7)	0.12 (3.0)	0.28 (7.1)	¼	29
53107	2	2.00 (50.8)	1.00 (25.4)	0.75 (19.1)	0.25 (6.4)	0.43 (10.9)	¼	45
53108	1	2.00 (50.8)	1.00 (25.4)	0.75 (19.1)	0.25 (6.4)	0.43 (10.9)	¼	45
53109	1/0	2.00 (50.8)	1.00 (25.4)	0.75 (19.1)	0.25 (6.4)	0.43 (10.9)	⅜	45
53161*	325/24	2.18 (55.4)	0.75 (19.1)	0.81 (20.6)	0.21 (5.3)	0.43 (10.9)	⅜	54
53110	2/0	2.63 (66.8)	1.25 (31.8)	1.00 (25.4)	0.28 (7.1)	0.53 (13.5)	⅜	66
53111	3/0	2.63 (66.8)	1.25 (31.8)	1.00 (25.4)	0.28 (7.1)	0.53 (13.5)	⅜	66
53112	4/0	2.63 (66.8)	1.25 (31.8)	1.00 (25.4)	0.28 (7.1)	0.53 (13.5)	⅜	66
53165*	650/24	3.06 (91.4)	1.38 (35.1)	1.18 (30.0)	0.31 (7.9)	0.75 (19.1)	½	76
53113	250 kcmil	3.06 (91.4)	1.50 (38.1)	1.18 (30.0)	0.31 (7.9)	0.75 (19.1)	½	76
53114	300 kcmil	3.06 (91.4)	1.50 (38.1)	1.18 (30.0)	0.31 (7.9)	0.75 (19.1)	½	76
53115	350 kcmil	3.81 (96.8)	2.00 (50.8)	1.38 (35.1)	0.38 (9.7)	0.81 (20.6)	½	99
53116	400 kcmil	3.81 (96.8)	2.00 (50.8)	1.38 (35.1)	0.38 (9.7)	0.81 (20.6)	½	99
53118	500 kcmil	3.81 (96.8)	2.00 (50.8)	1.38 (35.1)	0.38 (9.7)	0.81 (20.6)	½	99
53168*	1,100/24	3.81 (96.8)	1.63 (41.4)	1.63 (41.4)	0.40 (10.2)	0.88 (22.4)	½	107
53169*	1,325/24	3.81 (96.8)	1.63 (41.4)	1.63 (41.4)	0.40 (10.2)	0.88 (22.4)	½	107
53123	750 kcmil	4.18 (106.2)	2.12 (53.8)	1.63 (41.4)	0.43 (10.9)	1.00 (25.4)	½	112
53173*	2,750/24	5.06 (142.2)	1.88 (47.8)	2.12 (53.8)	0.56 (14.2)	1.18 (30.0)	½	150

Diagrams

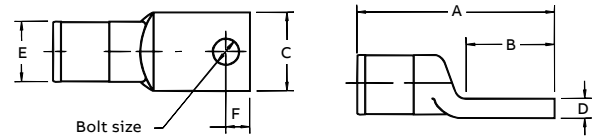

* For installations from 16 kV up to 35 kV, consult shielded cable manufacturers for stress relief and insulation requirements.

* Not UL Listed and CSA non applicable.

For tool and die selection charts, see the section E31-E48 of the Tools, Dies and Kits catalogue.

Compression connectors for copper conductors



Material – High-conductivity wrought copper

Finish – Electro tin plated



Cast copper two-hole lugs for code copper cable – Certified to 600 V and recommended up to 35 kV*

Cat. no.	Code cable size (AWG or kcmil)	Bolt size (in.)	Dimensions in. (mm)							No. of crimps			
			A	B	C	D	E	F	H	Die code	12 ton	15 ton	40 ton
256-30695-1055	#14-10	¼	2.00 (50.8)	1.31 (33.3)	0.50 (12.7)	0.12 (3.0)	0.38 (9.7)	0.25 (6.4)	0.63-0.75 (16.0-19.1)	29	1	1	1
53204	#8	¼	2.00 (50.8)	1.31 (33.3)	0.50 (12.7)	0.09 (2.3)	0.38 (9.7)	0.25 (6.4)	0.63 (16.0)	29	1	1	1
53205	#8	¼	2.00 (50.8)	1.31 (33.3)	0.50 (12.7)	0.12 (3.0)	0.38 (9.7)	0.25 (6.4)	0.63 (16.0)	29	1	1	1
53206	#4	¼	2.00 (50.8)	1.31 (33.3)	0.50 (12.7)	0.12 (3.0)	0.38 (9.7)	0.25 (6.4)	0.63 (16.0)	29	1	1	1
53207	#2	¼	3.00 (76.2)	2.00 (50.8)	0.75 (19.1)	0.12 (3.0)	0.59 (15.0)	0.50 (12.7)	0.75 (19.1)	45	1	1	1
53208	#1	¼	3.00 (76.2)	2.00 (50.8)	0.75 (19.1)	0.25 (6.4)	0.59 (15.0)	0.50 (12.7)	1.00 (25.4)	45	1	1	1
53209	1/0	⅜	3.00 (76.2)	2.00 (50.8)	0.75 (19.1)	0.25 (6.4)	0.59 (15.0)	0.50 (12.7)	1.00 (25.4)	45	1	1	1
53210	2/0	⅜	4.31 (109.5)	3.00 (76.2)	0.75 (19.1)	0.18 (4.6)	0.84 (21.3)	0.63 (16.0)	1.75 (44.5)	66	1	1	1
53211	3/0	½	4.31 (109.5)	3.00 (76.2)	1.00 (25.4)	0.28 (7.1)	0.84 (21.3)	0.63 (16.0)	1.75 (44.5)	66	1	1	1
53212	4/0	½	4.31 (109.5)	3.00 (76.2)	1.00 (25.4)	0.28 (7.1)	0.84 (21.3)	0.63 (16.0)	1.75 (44.5)	66	1	1	1
53213	250	½	4.56 (115.8)	3.00 (76.2)	1.18 (30.0)	0.18 (4.6)	0.93 (23.6)	0.63 (16.0)	1.75 (44.5)	76	1	1	1
53214	300	½	4.56 (115.8)	3.00 (76.2)	1.18 (30.0)	0.31 (7.9)	0.93 (23.6)	0.63 (16.0)	1.75 (44.5)	76	1	1	1
53215	350	½	5.31 (134.9)	3.50 (88.9)	1.38 (35.1)	0.25 (6.4)	1.21 (30.7)	0.63 (16.0)	1.75 (44.5)	99	2	1	1
53216	400	½	5.31 (134.9)	3.50 (88.9)	1.38 (35.1)	0.38 (9.7)	1.21 (30.7)	0.63 (16.0)	1.75 (44.5)	99	2	1	1
53218	500	½	5.31 (134.9)	3.50 (88.9)	1.38 (35.1)	0.38 (9.7)	1.21 (30.7)	0.63 (16.0)	1.75 (44.5)	99	2	1	1
53220M	600	½	5.31 (134.9)	3.50 (88.9)	1.63 (41.4)	0.53 (13.5)	1.35 (34.3)	0.63 (16.0)	1.75 (44.5)	112	2	1	1
53222M	700	½	5.31 (134.9)	3.50 (88.9)	1.63 (41.4)	0.03 (0.8) ±	1.35 (34.3)	0.63 (16.0)	1.75 (44.5)	112	2	1	1
53223M	750	½	5.31 (134.9)	3.50 (88.9)	1.63 (41.4)	0.03 (0.8) ±	1.35 (34.3)	0.63 (16.0)	1.75 (44.5)	112	2	1	1
53269*	1,325/24	½	5.50 (139.7)	3.50 (88.9)	1.63 (41.4)	0.40 (10.2)	1.35 (34.3)	0.63 (16.0)	1.75 (44.5)	107	2	1	1
53224	800	½	6.00 (152.4)	3.50 (88.9)	1.88 (47.8)	0.31 (7.9)	1.56 (39.6)	0.63 (16.0)	1.75 (44.5)	130	-	1	1
53226	900	½	6.00 (152.4)	3.50 (88.9)	1.88 (47.8)	0.46 (11.7)	1.56 (39.6)	0.63 (16.0)	1.75 (44.5)	130	-	1	1
53228	1000	½	6.00 (152.4)	3.50 (88.9)	1.88 (47.8)	0.46 (11.7)	1.56 (39.6)	0.63 (16.0)	1.75 (44.5)	130	-	1	1
53273*	1,100 2,750/24	½	6.19 (157.2)	3.50 (88.9)	2.12 (53.8)	0.56 (14.2)	1.90 (28.3)	0.63 (16.0)	1.75 (44.5)	150 or 150H	-	-	-
53233	1,500	½	6.25 (158.8)	3.50 (88.9)	2.25 (57.2)	0.50 (12.7)	1.90 (28.3)	0.63 (16.0)	1.75 (44.5)	150	-	1	1
53233L	1,500	½	7.31 (185.7)	3.12 (79.2)	2.00 (50.8)	0.50 (12.7)	1.88 (47.8)	0.63 (16.0)	1.75 (44.5)	150	-	1	-
53432L*	1,500	½	7.31 (185.7)	3.12 (79.2)	3.00 (76.2)	0.50 (12.7)	1.88 (47.8)	0.63 (16.0)	1.75 (44.5)	150	-	1	-
251-30485-1275	1,250	9/16	6.19 (157.2)	3.50 (88.9)	2.12 (53.8)	0.56 (14.2)	1.90 (48.3)	0.63 (16.0)	1.75 (44.5)	150	-	-	-
251-30485-1211	1,750	-	6.38 (162.1)	3.12 (79.2)	3.00 (76.2)	0.50 (12.7)	2.18 (55.4)	-	-	175	-	-	2 (fig. 2)
251-30485-1212	1,750	-	6.38 (162.1)	3.12 (79.2)	2.25 (57.2)	0.50 (12.7)	2.18 (55.4)	-	-	175	-	-	2 (fig. 1)
53239	2,000 169/110	½	6.19 (157.2)	3.50 (88.9)	2.75 (69.9)	0.50 (12.7)	2.18 (55.4)	0.63 (16.0)	0.63 (16.0)	175	-	-	-
53239L	178/0.104 2,000 169/0.110	½	7.31 (185.7)	3.12 (79.2)	2.25 (57.2)	0.50 (12.7)	2.46 (62.5)	0.63 (16.0)	0.63 (16.0)	175	-	-	-
53439L*	178/0.104 2,000	½	7.31 (185.7)	3.12 (79.2)	3.00 (76.2)	0.50 (12.7)	2.18 (55.4)	0.63 (16.0)	0.63 (16.0)	175	-	-	-11421 die

Diagrams

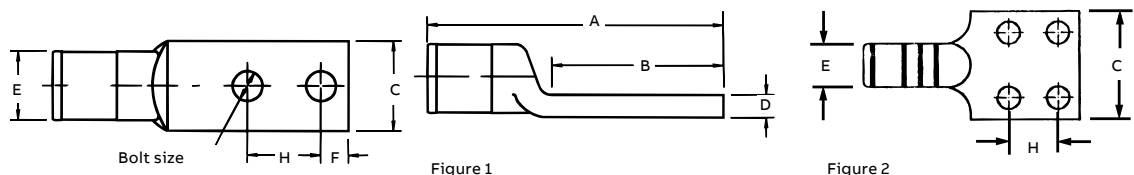

* For installations from 16 kV up to 35 kV, consult shielded cable manufacturers for stress relief and insulation requirements.

* Heavy-duty copper lugs for flexible strand cables 600 V not UL or CSA listed.

• CSA not applicable.

For tool and die selection charts, see the section E31-E48 of the Tools, Dies and Kits catalogue.

Compression connectors for copper conductors

Material – Cast copper

Color-Keyed method – Traction motor disconnect lugs for diesel-electric locomotives

Cat. no.	Cable size	Dimensions in. (mm)				Approx. dia. E in. (mm)	Bolt size in. (mm)			Die code
		A	B	C	D		F	G	H	
MD37	37/24	2.44 (62.0)	1.75 (44.5)	0.59 (15.0)	0.16 (4.1)	0.38 (9.7)	0.38 (9.7)	0.31 (7.9)	0.88 (24.4)	26
MDD61	61/24	2.44 (62.0)	1.75 (44.5)	0.59 (15.0)	0.16 (4.1)	0.38 (9.7)	0.38 (9.7)	0.31 (7.9)	0.88 (24.4)	26
MD 105	105/24	2.63 (66.8)	1.75 (44.5)	0.59 (15.0)	0.16 (4.1)	0.44 (11.2)	0.38 (9.7)	0.31 (7.9)	0.88 (24.4)	33
MD 105	91/24	2.63 (66.8)	1.75 (44.5)	0.59 (15.0)	0.16 (4.1)	0.44 (11.2)	0.38 (9.7)	0.31 (7.9)	0.88 (24.4)	33
MD 125	125/24	2.63 (66.8)	1.75 (44.5)	0.59 (15.0)	0.20 (5.2)	0.44 (11.2)	0.38 (9.7)	0.31 (7.9)	0.88 (24.4)	33
MD 150	150/24	2.06 (52.3)	1.88 (47.8)	0.59 (15.0)	0.20 (5.2)	0.63 (16.0)	0.44 (11.2)	0.31 (7.9)	0.88 (24.4)	45
MD 175	175/24	2.06 (52.3)	1.88 (47.8)	0.59 (15.0)	0.20 (5.2)	0.63 (16.0)	0.44 (11.2)	0.31 (7.9)	0.88 (24.4)	45
MD 225	225/24	3.00 (76.2)	1.88 (47.8)	0.69 (17.5)	0.20 (5.2)	0.72 (18.3)	0.44 (11.2)	0.31 (7.9)	0.88 (24.4)	60
MD 275	275/24	3.00 (76.2)	1.88 (47.8)	0.69 (17.5)	0.20 (5.2)	0.72 (18.3)	0.44 (11.2)	0.31 (7.9)	0.88 (24.4)	60
MD 325	325/24	3.00 (76.2)	1.88 (47.8)	0.69 (17.5)	0.20 (5.2)	0.72 (18.3)	0.44 (11.2)	0.31 (7.9)	0.88 (24.4)	60
MD 375	375/24	3.13 (79.5)	2.00 (50.8)	0.78 (19.8)	0.20 (5.2)	0.72 (18.3)	0.44 (11.2)	0.31 (7.9)	0.88 (24.4)	60
MD 450	450/24	3.13 (79.5)	2.00 (50.8)	0.78 (19.8)	0.20 (5.2)	0.72 (18.3)	0.44 (11.2)	0.31 (7.9)	0.88 (24.4)	60
MD 550	550/24	3.19 (81.0)	1.88 (47.8)	0.94 (23.9)	0.20 (5.2)	1.00 (25.4)	0.44 (11.2)	0.31 (7.9)	0.88 (24.4)	76
MD 650	650/24	3.19 (81.0)	1.88 (47.8)	0.94 (23.9)	0.20 (5.2)	1.00 (25.4)	0.44 (11.2)	0.31 (7.9)	0.88 (24.4)	76
MD 775	775/24	3.19 (81.0)	1.88 (47.8)	0.94 (23.9)	0.38 (9.5)	1.00 (25.4)	0.44 (11.2)	0.31 (7.9)	0.88 (24.4)	76
MD 925	925/24	3.75 (95.3)	2.06 (52.3)	1.13 (28.7)	0.38 (9.5)	1.16 (29.5)	0.44 (11.2)	0.38 (9.7)	1.00 (25.4)	87
MD 1100	1,100/24	3.75 (95.3)	2.06 (52.3)	1.34 (34.0)	0.38 (9.5)	1.38 (35.1)	0.44 (11.2)	0.38 (9.7)	1.00 (25.4)	107
MD 1325	1,325/24	3.78 (96.0)	2.09 (53.3)	1.16 (29.5)	0.38 (9.5)	1.75 (44.5)	0.44 (11.2)	0.38 (9.7)	1.00 (25.4)	107
MD 1600	1,600/24	3.75 (95.3)	2.06 (52.3)	1.34 (34.0)	0.38 (9.5)	1.38 (35.1)	0.44 (11.2)	0.38 (9.7)	1.00 (25.4)	107
MD 1925*	1,925/24	4.06 (103.1)	2.09 (53.3)	1.34 (34.0)	0.38 (9.5)	1.50 (38.1)	0.44 (11.2)	0.38 (9.7)	1.00 (25.4)	115
MD 2300	2,300/24	4.38 (111.3)	2.13 (54.1)	1.59 (40.4)	0.38 (9.5)	1.66 (42.2)	0.44 (11.2)	0.38 (9.7)	1.00 (25.4)	130

Diagrams

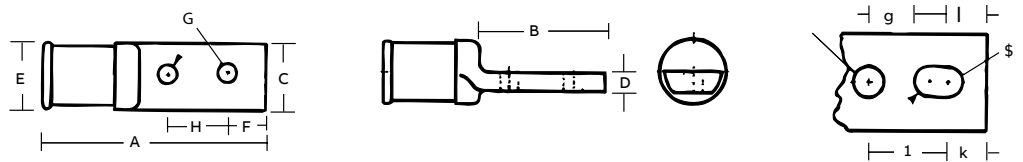

Note: some parts may not be current on the system. Consult your regional sales office for informations.

Tooling: all hydraulic tools 12 tons and up.

For use in mechanically splicing traction motor wires. MES Flex (B) and DLU.

* Supplied with elongated bolt hole.

Compression connectors for copper conductors



One-hole metric lugs

Color-Keyed metric lugs are manufactured from electrolytic copper tube. The dimensions of the tube are designed to obtain the most efficient electrical conductivity and mechanical strength, resisting vibration and pullout. Color-Keyed metric lugs are annealed to guarantee optimum ductility, which is a necessity for compression connectors having to withstand severe deformation arising when compressed or bending of the tongue that may happen during installation. Connectors have to perform adequately with vibration loads, and annealing is necessary to avoid material failure between the barrel and the tongue.

The presence of an inspection hole facilitates full insertion of the conductor, and the barrel length is designed to allow easy and accurate positioning of the dies during the crimping operation. Lugs are electrolytically tin-plated to eliminate oxidation of the copper material. Color-Keyed metric lugs complement our connector family and meet a growing need for customer's connector requirements. Details of the appropriate crimping tools and dies are included. Our ABB sales representative group is always available to provide any technical advice required. Please contact them if sizes are needed additional to those shown in this catalogue.



One-hole metric lugs

Cat. no.	Cond. size mm ²		Stud (mm)	Dimensions (mm)						Std. pkg.	6-tons	14-tons	26-tons
	Low stranded	Flexible		Ø1	B	M	N	L	D		TBM62PCR-LI (crimps)	TBM14CR-LI (crimps)	TBM26MCC (crimps)
MCC6M4*	-	4 ÷ 6	4	3.6	8.0	5.0	4.0	21.5	4.3	100	MCD6-6 (1)	-	-
MCC6M5*	-	4 ÷ 6	5	3.6	9.0	6.5	6.0	25.0	5.3	100	MCD6-6 (1)	-	-
MCC6M6*	-	4 ÷ 6	6	3.6	11.0	7.0	6.0	25.5	6.4	100	MCD6-6 (1)	-	-
MCC10M4	-	10	4	4.6	10.0	5.0	4.0	22.5	4.3	100	MCD10-6 (1)	MCD10-14 (1)	-
MCC10M5	-	10	5	4.6	10.0	6.5	6.0	26.0	5.3	100	MCD10-6 (1)	MCD10-14 (1)	-
MCC10M6	-	10	6	4.6	11.0	7.0	6.0	26.5	6.4	100	MCD10-6 (1)	MCD10-14 (1)	-
MCC10M8	-	10	8	4.6	15.0	9.0	8.0	30.5	8.4	100	MCD10-6 (1)	MCD10-14 (1)	-
MCC10M10	-	10	10	4.6	18.0	11.0	10.0	34.5	10.5	100	MCD10-6 (1)	MCD10-14 (1)	-
MCC16M4	-	16	4	5.8	11.5	5.0	4.0	25.5	4.3	100	MCD16-6 (1)	MCD16-14 (1)	-
MCC16M5	-	16	5	5.8	11.5	6.5	6.0	29.0	5.3	100	MCD16-6 (1)	MCD16-14 (1)	-
MCC16M6	-	16	6	5.8	11.5	7.0	6.0	29.5	6.4	100	MCD16-6 (1)	MCD16-14 (1)	-
MCC16M8	-	16	8	5.8	15.0	9.0	8.0	33.5	8.4	100	MCD16-6 (1)	MCD16-14 (1)	-
MCC16M10	-	16	10	5.8	18.0	11.0	10.0	37.5	10.5	100	MCD16-6 (1)	MCD16-14 (1)	-
MCC25M5	-	25	5	7.0	14.0	6.5	6.0	31.5	5.3	100	MCD25-6 (1)	MCD25-14 (1)	-
MCC25M6	-	25	6	7.0	14.0	7.0	6.0	32.0	6.4	100	MCD25-6 (1)	MCD25-14 (1)	-
MCC25M10	-	25	10	7.0	18.0	11.0	10.0	40.0	10.5	100	MCD25-6 (1)	MCD25-14 (1)	-
MCC35M5	35	25, 35	5	8.9	17.0	6.5	6.0	34.0	5.3	100	MCD35-6 (1)	MCD35-14 (1)	-
MCC35M6	35	25, 35	6	8.9	17.0	7.0	6.0	34.5	6.4	100	MCD35-6 (1)	MCD35-14 (1)	-
MCC35M8	35	25, 35	8	8.9	17.0	9.0	8.0	38.5	8.4	100	MCD35-6 (1)	MCD35-14 (1)	-
MCC35M10	35	25, 35	10	8.9	19.0	11.0	10.0	42.5	10.5	100	MCD35-6 (1)	MCD35-14 (1)	-
MCC35M12	35	25, 35	12	8.9	21.0	14.0	12.0	47.5	13.2	100	MCD35-6 (1)	MCD35-14 (1)	-
MCC50M8	50	35, 50	8	10.0	19.0	19.0	8.0	42.5	8.4	50	MCD50-6 (1)	MCD50-14 (1)	-
MCC50M10	50	35, 50	10	10.0	20.0	11.0	10.0	46.5	10.5	50	MCD50-6 (1)	MCD50-14 (1)	-
MCC50M12	50	35, 50	12	10.0	21.0	14.0	12.0	51.5	13.2	50	MCD50-6 (1)	MCD50-14 (1)	-

Diagram

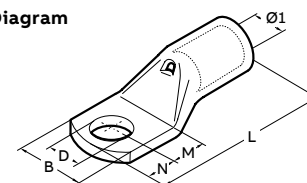

* UL not applicable.

Compression connectors for copper conductors



One-hole metric lugs (continued)

Cat. no.	Cond. size mm ²		Stud (mm)	Dimensions (mm)						Std. pkg.	6-tons TBM62PCR-LI (crimps)	14-tons TBM14CR-LI (crimps)	26-tons TBM26MCC (crimps)
	Low stranded	Flexible		Ø1	B	M	N	L	D				
MCC70M6	70	50, 70	6	11.3	21.0	8.0	7.0	44.0	6.4	50	MCD70-6 (1)	MCD70-14 (1)	-
MCC70M8	70	50, 70	8	11.3	21.0	9.0	8.0	46.0	8.4	50	MCD70-6 (1)	MCD70-14 (1)	-
MCC70M10	70	50, 70	10	11.3	21.0	11.0	10.0	50.0	10.5	50	MCD70-6 (1)	MCD70-14 (1)	-
MCC70M12	70	50, 70	12	11.3	22.0	14.0	12.0	55.0	13.2	50	MCD70-6 (1)	MCD70-14 (1)	-
MCC70M16	70	50, 70	16	11.3	26.0	18.0	16.0	63.0	17.0	50	MCD70-6 (1)	MCD70-14 (1)	-
MCC95M8	95	70, 95	8	13.5	25.0	9.0	8.0	52.5	8.4	50	MCD95-6 (1)	MCD95-14 (1)	-
MCC95M10	95	70, 95	10	13.5	25.0	11.0	10.0	56.5	10.5	50	MCD95-6 (1)	MCD95-14 (1)	-
MCC95M12	95	70, 95	12	13.5	25.0	14.0	12.0	61.5	13.2	50	MCD95-6 (1)	MCD95-14 (1)	-
MCC120M6*	120	95, 120	8	-	-	-	-	-	6.4	25	MCD120-6 (1)	MCD120-14 (1)	-
MCC120M8	120	95, 120	8	15.2	28.5	9.0	8.0	54.0	8.4	25	MCD120-6 (1)	MCD120-14 (1)	-
MCC120M10	120	95, 120	10	15.2	28.5	11.0	10.0	58.0	10.5	25	MCD120-6 (1)	MCD120-14 (1)	-
MCC120M12	120	95, 120	12	15.2	28.5	14.0	12.0	63.0	13.2	25	MCD120-6 (1)	MCD120-14 (1)	-
MCC120M16	120	95, 120	16	15.2	28.5	18.0	16.0	71.0	17.0	25	MCD120-6 (1)	MCD120-14 (1)	-
MCC150M10	150	120, 150	10	15.2	28.5	18.0	16.0	71.0	17.0	25	MCD150-6 (3)	MCD150-14 (1)	-
MCC150M12	150	120, 150	12	16.7	31.5	16.0	14.0	75.0	13.2	25	MCD150-6 (3)	MCD150-14 (1)	-
MCC150M16	150	120, 150	16	16.7	31.5	19.0	17.0	81.0	17.0	25	MCD150-6 (3)	MCD150-14 (1)	-
MCC185M10	185	150, 185	10	19.2	35.5	13.0	11.0	76.0	10.5	25	MCD185-6 (3)	MCD185-14 (1)	-
MCC185M12	185	150, 185	12	19.2	35.5	16.0	14.0	82.0	13.2	25	MCD185-6 (3)	MCD185-14 (1)	-
MCC185M16	185	150, 185	16	19.2	35.5	19.0	17.0	88.0	17.0	15	MCD185-6 (3)	MCD185-14 (1)	-
MCC240M10	240	185, 240	10	21.1	39.0	13.0	11.0	82.0	10.5	15	MCD240-6 (3)	MCD240-14 (2)	-
MCC240M12	240	185, 240	12	21.1	39.0	16.0	14.0	88.0	13.2	15	MCD240-6 (3)	MCD240-14 (2)	-
MCC240M16	240	185, 240	16	21.1	39.0	19.0	17.0	94.0	17.0	15	MCD240-6 (3)	MCD240-14 (2)	-
MCC300M10	300	240	10	23.7	44.0	13.0	11.0	96.0	10.5	10	-	MCD300-14 (3)	-
MCC300M12	300	240	12	23.7	44.0	16.0	14.0	99.0	13.2	10	-	MCD300-14 (3)	-
MCC300M16	300	240	16	23.7	44.0	19.0	19.0	10.0	17.0	10	-	MCD300-14 (3)	-
MCC400M10*	400	300	10	27.0	51.0	22.0	19.0	113.0	13.2	5	-	MCD400-14 (3)	MCD400-26 (2)
MCC400M12	400	300	12	27.0	51.0	22.0	19.0	113.0	13.2	5	-	MCD400-14 (3)	MCD400-26 (2)
MCC400M16	400	300	16	27.0	51.0	22.0	19.0	113.0	17.0	5	-	MCD400-14 (3)	MCD400-26 (2)
MCC500M10*	500	400	10	-	-	-	-	-	13.2	5	-	-	MCD500-26 (2)
MCC500M12*	500	400	12	-	-	-	-	-	17.0	5	-	-	MCD500-26 (2)
MCC500M16	500	400	16	30.3	56.5	22.0	19.0	117.0	17.0	5	-	-	MCD500-26 (2)
MCC630M16	630	500	16	33.4	61.6	22.0	19.0	128.0	17.0	6	-	-	MCD630-26 (2)
MCC630M20	630	500	20	33.4	61.6	24.0	23.0	134.0	21.0	6	-	-	MCD630-26 (2)
MCC800M16	800	630	16	38.0	72.0	24.0	19.0	141.0	17.0	3	-	-	-
MCC800M20	800	630	20	38.0	72.0	24.0	23.0	145.0	21.0	3	-	-	-
MCC1000M16	1,000	800	16	44.0	80.0	24.0	19.0	158.0	17.0	2	-	-	-
MCC1000M20	1,000	800	20	44.0	80.0	24.0	23.0	162.0	21.0	2	-	-	-

Diagram

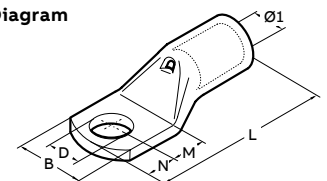

* UL not applicable.

Compression connectors for copper conductors



Narrow-tongue metric lugs

Color-Keyed narrow-tongue metric lugs feature a contained tongue width.

Our lugs have been specifically developed for applications with low voltage circuit breakers with reduced space requirements. The tongue width allows a quicker and easier installation.

Color-Keyed narrow-tongue metric lugs are manufactured from electrolytic copper tube.

The specific design of the barrel and dimensions create the best combination of mechanical strength and electrical conductivity.

Color-Keyed narrow-tongue metric lugs are annealed to guarantee optimum ductility and are electrolytically tin-plated to avoid oxidation. The barrel is provided with an internal chamfer for easy insertion of the conductor.

The length allows easy positioning of the dies for proper crimping.



Narrow-tongue metric lugs

Cat. no.	Cond. size flexible (mm ²)	Stud (mm)	Dimensions (mm)							Std. pkg.	6-tons TBM62PCR-LI (crimps)	14-tons TBM14CR-LI (crimps)
			Ø1	B	M	N	L	D				
MCCNT10M5	10	5	4.6	9.0	6.5	6.0	26.0	5.3	100	MCD10-6 (1)	MCD10-14 (1)	
MCCNT16M5	16	5	5.8	9.0	6.5	6.0	29.0	5.3	100	MCD16-6 (1)	MCD16-14 (1)	
MCCNT25M5	25	5	7.0	9.0	6.5	6.0	31.5	5.3	100	MCD25-6 (1)	MCD25-14 (1)	
MCCNT35M6	35	6	8.9	11.5	8.0	7.0	36.5	6.4	100	MCD35-6 (2)	MCD35-14 (1)	
MCCNT50M6	50	6	10.0	11.5	8.0	7.0	40.5	6.4	50	MCD50-6 (1)	MCD50-14 (1)	
MCCNT70M6	70	6	11.3	11.5	8.0	7.0	44.0	6.4	50	MCD70-6 (2)	MCD70-14 (1)	
MCCNT95M8	95	8	13.5	15.5	9.0	8.0	52.5	8.0	25	MCD95-6 (1)	MCD95-14 (1)	
MCCNT120M8	120	8	15.2	19.0	14.0	9.0	60.0	8.4	25	MCD120-6 (2)	MCD120-14 (1)	
MCCNT120M10	120	10	15.2	19.0	14.0	9.0	60.0	10.5	25	MCD120-6 (2)	MCD120-14 (1)	
MCCNT150M8	150	8	16.7	19.0	18.0	9.0	70.0	8.4	25	MCD150-6 (3)	MCD150-14 (1)	
MCCNT150M10	150	10	16.7	19.0	18.0	9.0	70.0	10.5	25	MCD150-6 (3)	MCD150-14 (1)	
MCCNT185M10	185	10	19.2	24.5	18.0	9.0	77.0	10.5	25	MCD185-6 (3)	MCD185-14 (1)	
MCCNT240M10	240	10	21.1	31.0	13.0	9.0	80.0	10.5	15	MCD240-6 (3)	MCD240-14 (1)	
MCCNT240M12	240	12	21.1	31.0	16.0	12.0	86.0	13.2	15	MCD240-6 (3)	MCD240-14 (1)	
MCCNT240M16	240	16	21.1	31.0	19.0	17.0	94.0	17.0	15	MCD240-6 (3)	MCD240-14 (1)	
MCCNT300M12	300	12	23.7	31.0	16.0	12.0	95.0	13.2	10	-	MCD300-14 (3)	

Diagram

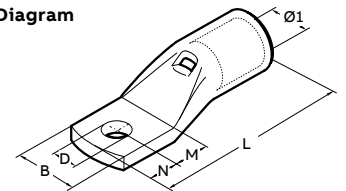

Compression connectors for copper conductors



Two-way metric splice connectors

Color-Keyed metric splice connectors are designed for joining low voltage conductors.

Made of electrolytic copper tube having similar dimensions to the Color-Keyed metric lugs, these connectors are also annealed and electrolytically tin-plated.

They feature an internal chamfer at both ends. For easy insertion of the conductor, a center stop is provided to ensure correct positioning.

Two-way metric splice connectors

Cat. no.	Cond. size (mm ²)		Dimensions (mm)		Std. pkg.	6-tons TBM62PCR-LI (crimps)	14-tons TBM14CR-LI (crimps)	26-tons TBM26MCC (crimps)
	Low stranded	Flexible	Ø1	L				
MCST1	0.25 ÷ 1.5	0.25 ÷ 1.5	1.8	15	100	-	-	-
MCST2	1.5 ÷ 2.5	1.5 ÷ 2.5	2.4	15	100	-	-	-
MCST6	4 ÷ 6	4 ÷ 6	3.6	22	100	MCD6-6 (1 +1)	-	-
MCST10	10	10	4.6	25	100	MCD10-6 (1 +1)	MCD10-14 (1 +1)	-
MCST16	16	16	5.8	27	100	MCD16-6 (1 +1)	MCD16-14 (1 +1)	-
MCST25	25	25	7.0	29	100	MCD25-6 (1 +1)	MCD25-14 (1 +1)	-
MCST35	35	25 ÷ 35	8.9	332	100	MCD35-6 (1 +1)	MCD35-14 (1 +1)	-
MCST50	50	35 ÷ 50	10.0	37	50	MCD50-6 (2 +2)	MCD50-14 (1 +1)	-
MCST70	70	50 ÷ 70	11.3	39	50	MCD70-6 (2 +2)	MCD70-14 (1 +1)	-
MCST95	95	70 ÷ 95	13.5	43	25	MCD95-6 (2 +2)	MCD95-14 (1 +1)	-
MCST120	120	95 ÷ 120	15.2	47	25	MCD120-6 (2 +2)	MCD120-14 (1 +1)	-
MCST150	150	120 ÷ 150	16.7	58	25	MCD150-6 (3 +3)	MCD150-14 (1 +1)	-
MCST185	185	150 ÷ 85	19.2	64	25	MCD185-6 (3 +3)	MCD185-14 (1 +1)	-
MCST240	240	185 ÷ 240	21.1	75	15	MCD240-6 (3 +3)	MCD240-14 (2 +2)	-
MCST300	300	240	23.7	90	10	-	MCD300-14 (3 +3)	-
MCST400	400	300	27.0	94	5	-	MCD400-14 (3 +3)	MCD400-26 (2 +2)
MCST500	500	400	30.3	98	6	-	-	MCD500-26 (2 +2)
MCST630	600 ÷ 630	500	33.4	105	6	-	-	MCD630-26 (2 +2)
MCST800	800	600	38.0	112	3	-	-	-
MCST1000	1,000	800	44.0	120	3	-	-	-

Diagram

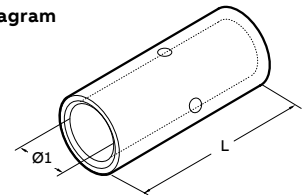

Compression connectors for copper conductors



Material – High conductivity wrought copper

Finish – Electro tin plated

Two-way connectors provide high pullout values, are easy to insulate and provide a low-resistance connection of high quality and low installed cost.



Two-way splice connectors – Standard barrel certified to 600 V and recommended up to 35 kV[†]

Cat. no.	Code cable (AWG or kcmil)	Wire size Flex cable classes G, H, I, K, M*	Dimensions in. (mm)		Die set cat. no.	Colour code
			A	E		
54504	#8	#8 AWG, 37/24, #8 Weld	1.00 (25.4)	0.27 (6.9)	21	Red
54505	#6	#6 AWG, 61/24, #6 Weld, 133/0.014	1.00 (25.4)	0.30 (7.6)	24	Blue
54506	#4	#4 AWG, 91/24, 133/0.0177, 49/0.029	1.00 (25.4)	0.37 (9.4)	29	Grey
54507	#2	125/24, #4 Weld	1.25 (31.8)	0.41 (10.4)	33	Brown
54508	#1	#2 AWG, 150/24, 175/24, #2 Weld, 133/0.0223	1.50 (38.1)	0.47 (11.9)	37	Green
54509	1/0	225/24, #1 Weld, 133/0.0254	1.63 (41.4)	0.52 (13.2)	42	Pink
54510	2/0	1/0 AWG, 275/24, 1/0 Weld, 427/0.0155, 133/0.0282	1.75 (44.5)	0.57 (14.5)	45	Black
54511	3/0	2/0 AWG, 325/24, 2/0 Weld, 133/0.0316, 259/0.0227, 427/0.0177	1.75 (44.5)	0.63 (16.0)	50	Orange
53962	–	375/24, 179 kcmil, 133/0.0355, 259/0.0255, 427/0.0199	1.81 (46.0)	0.70 (17.8)	50	Orange
54512	4/0	3/0 AWG, 450/24, 3/0 Weld, 703/0.0154	1.88 (47.8)	0.70 (17.8)	54	Purple
54513	250	4/0 AWG, 550/24, 4/0 Weld, 133/0.0399, 259/0.0286, 637/0.0183	2.25 (57.2)	0.77 (19.6)	62	Yellow
53964	–	4/0 AWG, 550/24, 4/0 Weld, 133/0.0399, 259/0.0286, 637/0.0183	2.13 (54.1)	0.79 (20.1)	62	Yellow
54514	300	–	2.13 (54.1)	0.83 (21.1)	66	White
54515	350	–	2.25 (57.2)	0.90 (22.9)	71	Red
54516	400	–	2.75 (69.9)	0.93 (23.6)	76	Blue
53968	–	300 kcmil, 775/24 (313 kcmil)	3.00 (76.2)	1.13 (28.7)	87	Brown
54518	500	–	2.75 (69.9)	1.11 (28.2)	87	Brown
54520	600	–	3.00 (76.2)	1.18 (30.0)	94	Green
54522-TB	700	–	3.25 (82.6)	1.23 (31.2)	99	Pink
53969	–	1325/24 = 500/535 kcmil, 427/0.0342	3.00 (76.2)	1.24 (31.5)	99	Pink
54523-TB	750	–	3.00 (76.2)	1.30 (33.0)	106	Black
54528	1,000	–	3.63 (92.2)	1.50 (38.1)	125	–
54530	1,250	–	4.13 (104.9)	1.67 (42.4)	140	–

Diagram

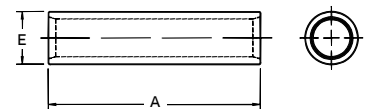

[†] For installations from 16 kV up to 35 kV, consult shielded cable manufacturers for stress relief and insulation requirements.

*Consult your regional sales office for complete list of flex cable class sizes M.

For tool and die selection charts, see the section E31-E48 of the Tools, Dies and Kits catalogue.

Compression connectors for copper conductors



Material – High conductivity wrought copper
Finish – Electro tin plated



Two-way splice connectors – Long barrel certified to 600 V and recommended up to 35 kV*

Cat. no.	Code cable (AWG or kcmil)	Wire size Flex cable classes G, H, I, K, M	Dimensions in. (mm)		Die code	Colour code
			A	E		
54804	#8	#8, 37/24 = 14.9 kcmil	1.75 (44.5)	0.27 (6.9)	21	Red
54805	#6	#6, 61/24 = 24.6 kcmil	1.75 (44.5)	0.31 (7.9)	24	Blue
54806	#4	#4, 91/24 = 36.7 kcmil	1.75 (44.5)	0.39 (9.9)	29	Grey
54807	#2	125/24 = 50.4 kcmil	1.88 (47.8)	0.43 (11.0)	33	Brown
54808	#1	#2, 150/24 = 60.5 kcmil, 175/24 = 70.6 kcmil	2.00 (50.8)	0.49 (12.4)	37	Green
54809	1/0	225/24 = 90.8 kcmil	2.00 (50.8)	0.54 (13.7)	42	Pink
54810	2/0	1/0, 275/24 = 111 kcmil	2.13 (54.1)	0.59 (15.0)	45	Black
54811	3/0	2/0, 325/24 = 131 kcmil	2.25 (57.2)	0.65 (16.5)	50	Orange
54812	4/0	450/24 = 182 kcmil	2.75 (69.9)	0.72 (18.3)	54	Purple
54813	250	4/0, 550/24 = 222 kcmil	3.38 (85.9)	0.79 (20.1)	62	Yellow
54814	300	250, 650/24 = 262 kcmil	3.50 (88.9)	0.87 (22.1)	66	White
54815	350	–	3.75 (95.3)	0.95 (24.1)	71	Red
54816	400	775/24 = 313 kcmil	3.75 (95.3)	0.98 (24.9)	76	Blue
54818	500	350, 925/24 = 373 kcmil	4.75 (120.6)	1.11 (28.2)	87	Brown
54820	600	1,100/24 = 444 kcmil	4.25 (108.0)	1.21 (30.7)	94	Green
54823	750	500, 1,325/24 = 535 kcmil	4.75 (120.6)	1.34 (34.0)	106	Black
58524	750	1,600/24 = 646 kcmil	5.00 (127.0)	1.39 (35.3)	106	Black
58526*	900	750, 1,925/24 = 777 kcmil	5.50 (139.7)	1.51 (38.4)	115	Yellow
54828	1,000	–	5.63 (143.0)	1.56 (39.6)	125	–
54833	1,500	–	5.63 (143.0)	1.56 (39.6)	125	–
54839	2,000	–	7.06 (179.3)	2.13 (54.1)	–	–

Diagram



* For installations from 16 kV up to 35 kV, consult shielded cable manufacturers for stress relief and insulation requirements.
 For tool and die selection charts, see the section E31-E48 of the Tools, Dies and Kits catalogue.
 CSA approved standard cable only.

Compression connectors for copper conductors



Copper two-way splice – Certified to 600 V and recommended up to 15 kV

Cat. no.	Cable size (AWG or kcmil)**	Dimensions in. (mm)		Die set Cat. no.	Strip length (in.)	Colour code
		A	B			
54006-TB	#4	2.00 (50.8)	0.37 (9.4)	15CA29R	1½	Grey
54007-TB	#2	2.13 (54.1)	0.41 (10.4)	15CA33R	1⅝	Brown
54008-TB	#1	2.25 (57.2)	0.47 (11.9)	15CA37R	1⅝	Green
54009-TB	1/0	2.38 (60.5)	0.52 (13.2)	15CA42R	1¾	Pink
54010	2/0	2.38 (60.5)	0.57 (14.5)	15CA45R	1¾	Black
54011	3/0	2.63 (66.8)	0.63 (16.0)	15CA49R	1 ¹³ / ₁₆	Orange
54012-TB	4/0	2.69 (68.3)	0.69 (17.5)	15CA54R	1 ¹³ / ₁₆	Purple
54013	250	3.19 (81.0)	0.74 (18.8)	15CA60R	2⅛	Ruby
54015	350	4.13 (104.9)	0.89 (22.6)	15CA71R	2⅝	Red
54018	500	4.13 (104.9)	1.06 (40.6)	15CA87R	2⅝	Brown
54023	750	4.75 (120.7)	1.30 (33.0)	15CA106R	2⅞	Black

Installing tools 14 and 15-tons*

Diagram

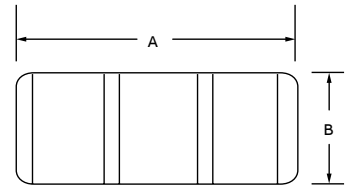

*Cat. no. 15505-TB die adaptor required for TBM151.

** Cable size: Concentric and compact strandings.

For tool and die selection charts, see the section E31-E48 of the Tools, Dies and Kits catalogue.



Material – Cast copper

Finish – Electro tin plated



Cast-copper two-way splice connectors – heavy-duty certified to 600 V and recommended up to 35 kV[†]

Cat. no.	Cable size (AWG or kcmil)	Die code
53504	#8	29
53505	#6	29
53506	#4	29
53507	#2	45
53508	#1	45
53509	1/0	45
53510	2/0	66
53511	3/0	66
53512	4/0	66
53513	250	76
53515	350	99
53518	500	99
53523	750	112

[†] For installations from 16 kV up to 35 kV, consult shielded cable manufacturers for stress relief and insulation requirements.

Use hydraulic tools with hex dies 13642M, 13400 and 21940.

For tool and die selection charts, see the section E31-E48 of the Tools, Dies and Kits catalogue.

Compression connectors for copper conductors

Constant O.D. enables faster, easier installation than contoured design



Cast-copper reducing splices

ABB takes the splicing of different-sized conductors to a new level of economy and efficiency with Color-Keyed cast-copper reducing splices. In addition to a lower cost, the key benefit to these splices is in their constant outer diameter. Unlike screw-machined, externally contoured splices, cast-copper reducing splices require no change of tool or die between crimping each end. Just slide each wire easily into the chamfered barrel and use the same Color-Keyed tool and die to crimp both ends. The consistent O.D. also makes these splices faster and easier to insulate with clear heat-shrink wrap than a contoured splice. Sand-cast construction ensures high-tensile strength for heavy-duty applications and tin-plated copper material provides high conductivity and superior corrosion resistance.

- Ideal for telecom (inside office/outside plant), commercial, industrial MRO and any other certified to 600 V and recommended up to 35 kV[†] applications requiring splicing of different-sized conductors.
- Tin-plated, sand-cast copper construction provides superior tensile strength, high conductivity and excellent corrosion resistance.
- Easier to install and insulate than screw-machined, contour-designed reducing splices.
- Constant O.D. saves time on installation by eliminating the need for crimp-tool/die change.
- Fast and simple to insulate with clear or coloured heat-shrink wrap.
- Chamfered barrel facilitates easy wire insertion.
- Compact, low-profile design takes up minimal space in cable tray or wire run.
- Simple installation with Color-Keyed crimp tools (12, 14 and 15 ton).



Cast-copper reducing splices

Cat. No.	Cond. 1 size (AWG or kcmil)	Cond. 2 size (AWG or kcmil)	Length in. (mm)	Dia. in. (mm)	Die Code	Colour Code
251-30485-19	4/0 Str.	2 Str.	2.25 (57.2)	0.81 (20.6)	66	White
251-30485-91	500 kcmil Str.	300 kcmil Str.	3.31 (84.1)	0.81 (20.6)	99	Pink
251-30485-229	2/0 Str.	250 kcmil Str.	2.38 (60.5)	0.93 (23.6)	76	Blue
251-30485-247	2 Str.	8 Str.	0.56 (14.2)	0.59 (15.0)	45	Black
251-30485-294	4 Str.	2/0 Str.	2.25 (57.2)	0.84 (21.3)	66	White
251-30485-295	4/0 Str.	4 Str.	2.25 (57.2)	0.81 (20.6)	66	White
251-30485-331	4/0 Str.	350 kcmil Str.	3.31 (84.1)	0.53 (13.5)	99	Pink
251-30485-445	4/0 Str.	2/0 Str.	2.25 (57.2)	0.81 (20.6)	66	White
251-30485-495	1/0 Str.	2 Str.	1.56 (39.6)	0.59 (15.0)	45	Black
251-30485-610	6 Str.	8 Str.	1.21 (30.7)	0.38 (9.7)	29	Grey
251-30485-611	4 Str.	8 Str.	1.21 (30.7)	0.38 (9.7)	29	Grey
251-30485-612	4 Str.	6 Str.	1.21 (30.7)	0.38 (9.7)	29	Grey
251-30485-613	2 Str.	6 Str.	1.56 (39.6)	0.59 (15.0)	45	Black
251-30485-640	4/0 Str.	1/0 Str.	2.25 (57.2)	0.81 (20.6)	66	White
251-30485-653	2 Str.	250 kcmil Str.	2.38 (60.5)	0.93 (23.6)	76	Blue
251-30485-739	1/0 Str.	250 kcmil Str.	2.38 (60.5)	0.93 (23.6)	76	Blue
251-30485-882	400 kcmil Str.	350 kcmil Str.	3.31 (84.1)	0.53 (13.5)	99	Pink
251-30485-950	1/0 Str.	6 Str.	1.56 (39.6)	0.59 (15.0)	45	Black
251-30485-951	6 Str.	2/0 Str.	2.25 (57.2)	0.84 (21.3)	66	White
251-30485-1027	1/0 Str.	4 Str.	1.56 (39.6)	0.59 (15.0)	45	Black
251-30485-1029	1/0 Str.	#12 Str.	1.56 (39.6)	0.57 (14.5)	45	Black
251-30485-1030	10 Str.	4 Str.	1.21 (30.7)	0.38 (9.7)	29	Grey
251-30485-1031	12 Str.	4 Str.	1.21 (30.7)	0.38 (9.7)	29	Grey
251-30485-1032	#6 Str.	#10 Str.	1.21 (30.7)	0.38 (9.7)	29	Grey
251-30485-1033	12 Str.	6 Str.	1.21 (30.7)	0.38 (9.7)	29	Grey
251-30485-1034	14 Str.	8 Str.	1.21 (30.7)	0.38 (9.7)	29	Grey
251-30485-1035	1 Str.	1/0 Str.	1.56 (39.6)	0.59 (15.0)	45	Black
251-30485-1044	10 Str.	8 Str.	1.21 (30.7)	0.38 (9.7)	29	Grey
251-30485-1045	12 Str.	8 Str.	1.21 (30.7)	0.38 (9.7)	29	Grey
251-30485-1085	10 Str.	1/0 Str.	1.56 (39.6)	0.59 (15.0)	45	Black
251-30485-1086	10 Str.	2/0 Str.	2.25 (57.2)	0.84 (21.3)	66	White
251-30485-1087	4 Str.	250 kcmil Str.	2.38 (60.5)	0.93 (23.6)	76	Blue
251-30485-1088	400 kcmil Str.	250 kcmil Str.	3.31 (84.1)	0.53 (13.5)	99	Pink
251-30485-1089	14 Str.	8 Sol.	1.21 (30.7)	0.38 (9.7)	29	Grey
251-30485-1090	12 Str.	8 Sol.	1.21 (30.7)	0.38 (9.7)	29	Grey
251-30485-1091	10 Str.	8 Sol.	1.21 (30.7)	0.38 (9.7)	29	Grey
251-30485-1092	12 Str.	6 Sol.	1.21 (30.7)	0.38 (9.7)	29	Grey
251-30485-1093	8 Str.	6 Sol.	1.21 (30.7)	0.38 (9.7)	29	Grey
251-30485-1094	4 Str.	6 Sol.	1.21 (30.7)	0.38 (9.7)	29	Grey
251-30485-1095	2 Str.	6 Sol.	1.56 (39.6)	0.59 (15.0)	45	Black
251-30485-1096	12 Str.	4 Sol.	1.21 (30.7)	0.38 (9.7)	29	Grey
251-30485-1097	10 Str.	4 Sol.	1.21 (30.7)	0.38 (9.7)	29	Grey
251-30485-1098	8 Str.	4 Sol.	1.21 (30.7)	0.38 (9.7)	29	Grey
251-30485-1099	6 Str.	4 Sol.	1.21 (30.7)	0.38 (9.7)	29	Grey
251-30485-1100	1/0 Str.	4 Sol.	1.56 (39.6)	0.59 (15.0)	45	Black
251-30485-1130	Cast Copper*	12-4 Str.	1.28 (32.5)	0.38 (9.7)	29	Black
251-30485-1245	1/0 Flex	#4 Flex	2.25 (57.2)	0.81 (20.6)	66	White
251-30485-1246	#4 Flex	#8 Flex	1.56 (39.6)	0.57 (14.5)	45	Black

[†] For installations from 16 kV up to 35 kV, consult shielded cable manufacturers for stress relief and insulation requirements.

* Cast copper – field-modifiable special.

Copper H-tap connectors for copper conductors

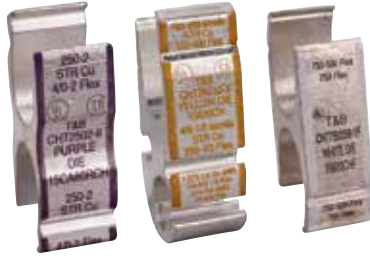

Material – High conductivity extruded copper

Finish – Electro tin plated



Copper H-taps – Certified to 600 V

Cat. no.	Fig. no.	Colour code	Wire size (AWG or kcmil)				Hydraulic head	Installing die	# of crimps	Colour code	Die code	Strip length (in.)	Insulating covers	Crimping information	
			Main	Branch 1	Branch 2	Branch 3									
CHT750350-1F	1	White	(750–500) (750) Flex only	(750–500) (350) Flex only	–	–	TBM15I	15620CHF	1	White	F	1½	HTC		
CHT750350-2	2	Yellow	750–500 (550–500)	750–500 (550–350)	–	–	TBM15I	15620CH	1	Yellow	Z	1¾	HTC500		
CHT75010-3	9	Yellow	750–500 (550–500)	4/0–1/0 (250–1/0)	1 Str. 2–6 AWG (1–8)	2–14 (2–14)	TBM15I	15620CH	1	Yellow	Z	1½	HTC500		
CHT50040-4	2	Brown	500–250 (350–4/0)	500–4/0 (350–4/0)	–	–	TBM15I	15612CH	2	Brown	N	1½	HTC500		
CHT50010-5	3	Brown	500–250 (350–4/0)	250–1/0 (4/0–1/0)	1 Str. 2–6 AWG (1–8)	8–14 (8–14)	TBM15I	15612CH	2	Brown	N	1½	HTC500		
CHT2502-6	2	Purple	250–2 (4/0–2)	250–2 (4/0–2)	–	–	•TBM15I TBM14M	15CA80RCH	1	Purple	80R	1⅜	HTC40		
CHT25014-7	4	Purple	250–2 (4/0–2)	2–6 Str./Sol. (2–8)	8–14 (8–14)	–	•TBM15I TBM14M	15CA80RCH	1	Purple	80R	1½	HTC40		
CHT250214-8	5	Purple	250–2 (4/0–2)	8–14 (8–14)	8–14 (8–14)	–	•TBM15I TBM14M	15CA80RCH	1	Purple	80R	1½	HTC40		
CHT214-9	6	Brown	2–6 Str./Sol. (2–8)	2–6 Str./Sol. (2–8)	8–14 (8–14)	8–14 (8–14)	•TBM15I TBM14M 13100A	15CA71RCH	3	Brown	71R	7/8	HTC40		
CHT814-10	7	Green	8–14 (8–14)	8–14 (8–14)	8–14 (8–14)	8–14 (8–14)	•TBM15I TBM14M 13100A	15CA37RCH	1	Green	37R	½	HTC25		
CHT75040-11	8	Yellow	750 Str. (750–500)	350–4/0 Str. Cu. & Flex	8–14 (8–14)	8–14 (8–14)	TBM15I	15620CH	1	Yellow	Z	1½	HTC500		

• Requires adaptor cat. no. 15500-TB when used with hydraulic head TBM15I.

Material: Copper per AS™ designation B-124-55 Alloy 12.

For tool and die selection charts, see the section E31-E48 of the Tools, Dies and Kits catalogue.

Copper H-tap connectors for copper conductors

Material – High conductivity extruded copper
Finish – Electro tin plated



Copper H-taps – Certified to 600 V (continued)

Cat. no.	Fig. no.	Dimensions in. (mm)									Strip length (in.)	Insulating covers
		H	W	L	A	D	D1	D2	D3			
CHT750350-1F	1	3.46 (87.9)	1.66 (42.1)	1.10 (27.9)	1.73 (43.9)	1.23 (31.2)	–	–	–	1 1/8	HTC1000	
CHT750350-2	2	3.24 (82.3)	1.50 (38.1)	1.25 (31.8)	1.62 (41.1)	1.02 (30.5)	–	–	–	1 3/8	HTC500	
CHT75010-3	9	3.13 (79.5)	1.50 (38.1)	1.00 (25.4)	1.54 (39.1)	1.00 (25.4)	0.40 (10.2)	0.35 (8.9)	0.41 (10.4)	1 1/8	HTC500	
CHT75040-11	8	3.19 (81.0)	(1) 1.65 (41.9) (2) 1.05 (26.7)	1.00 (25.4)	(1) 1.61 (40.9) (2) 1.29 (32.8)	(1) 1.24 (31.5) (2) 0.80 (20.3)	–	–	–	1 1/8	HTC500	
CHT50040-4	2	2.64 (67.1)	1.18 (30.0)	1.00 (25.4)	1.32 (33.5)	0.80 (20.3)	–	–	–	1 1/8	HTC500	
CHT50010-5	3	2.28 (57.9)	1.30 (33.0)	1.00 (25.4)	1.20 (30.5)	0.80 (20.3)	0.67 (17.0)	0.19 (4.8)	0.43 (10.9)	1 1/8	HTC500	
CHT2502-6	2	1.99 (50.9)	0.90 (22.9)	0.66 (16.8)	1.00 (25.4)	0.62 (15.7)	–	–	–	1 3/16	HTC40	
CHT25014-7	4	1.63 (41.4)	0.90 (22.9)	0.90 (22.9)	0.96 (24.4)	0.52 (13.2)	0.35 (8.9)	0.19 (4.8)	–	1 1/8	HTC40	
CHT250214-8	5	1.63 (41.4)	0.90 (22.9)	0.90 (22.9)	0.96 (24.4)	0.62 (15.7)	0.19 (4.8)	0.19 (4.8)	–	1 1/8	HTC40	
CHT214-9	6	1.35 (34.3)	0.60 (15.2)	0.75 (19.1)	0.50 (12.7)	0.33 (8.4)	0.19 (4.8)	0.19 (4.8)	–	7/8	HTC40	
CHT814-10	7	0.62 (15.7)	0.60 (15.2)	0.37 (9.4)	0.25 (6.4)	0.16 (4.1)	–	–	–	1/2	HTC2S	

Diagrams

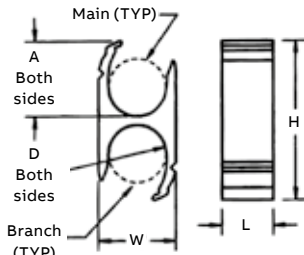

Figure 1

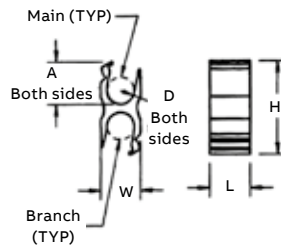

Figure 2

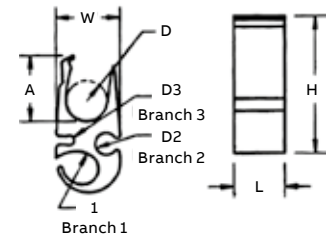

Figure 3

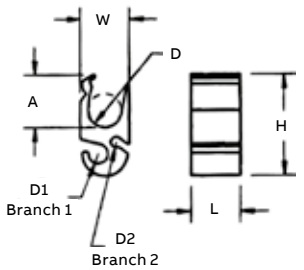

Figure 4

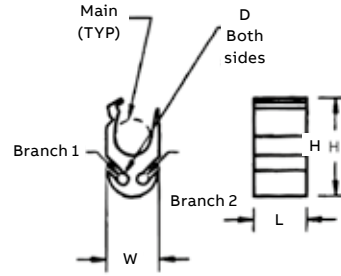

Figure 5

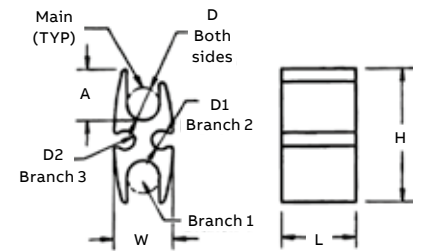

Figure 6

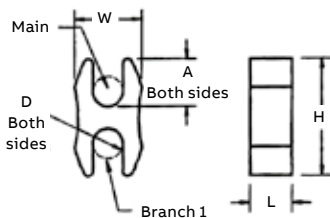

Figure 7

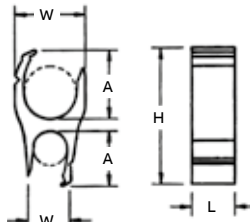

Figure 8

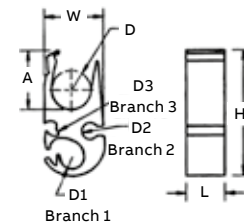

Figure 9

Aluminum H-tap connectors

Exclusive FILLERLOK tab design



Material – High-conductivity wrought aluminum

- H-type compression taps
- For aluminum-to-aluminum, aluminum-to-copper and copper-to-copper stranded-conductor applications
- Concentric and compact code strandings



Copper H-taps – Certified to 600 V 90°C applications

Cat. no.	Wire combinations (AWG or kcmil)			Length (in.)	Die code cat. no.				Colour code
	Main	Branch	Side tap		TBM6-TBM6S TBM6ORS	Hydraulic TBM14M 13100A	TBM12 12-ton head	TBM151 15-ton head	
63105†	2-6	8-14	-	¾	13474 - upper 13477 - lower	15530	TBM12D-4	15530*	Orange
63110	4-6	4-6	-	1½	13470	15501A	TBM12D-H	15001A*	Green
63118	2/0-2	8-14	-	¾	13470	15501A	TBM12D-H	15001A*	Green
63125	2/0-2	1/0-6	-	1½	13470	15501A	TBM12D-H	15001A*	Green
63140	4/0-2/0	2-10	-	1½	13471	15502	TBM12D-H	15502*	Blue
63148•	4/0-2/0	3/0-1	8-14	3	-	-	TBM12D-H	15502	Blue
63160	500-4/0	4/0-2	2-6	2¾	-	-	-	15612	Red
63169	750-4/0	750-4/0	-	3	-	-	-	15620	Black
63170	1,000-500	1,000-1/0	-	6	-	-	-	15620	Black
63180	750-350	350-1/0	1-6	3	-	-	-	15620	Black

* Use with adaptor cat.no.15500-TB.

† 63105 also installed by TBM5/TBM5S with 13455 die or TBM8/TBM8S with 13462 die.

• 63148 - #1 CU or AL - wire bent double (hairpin).

For Smart™ tools installation

63110,63118,63125: Use TBM8-750HG

63140,63148:Use TBM8-750BH

For tool and die selection charts, see the section E31-E48 of the Tools, Dies and Kits catalogue.

Interlocking insulating covers for compression taps

Better covers for taps

- 01 Smaller size requires less space in enclosure. High-impact polypropylene for rugged, dependable use.
- 02 Clear, polycarbonate (UL94V-0) version available.
- 03 Easy latch mechanism.

Soft shell H-tap/C-tap covers

ABB offers an improved design for one-piece covers for H-tap and C-tap connectors. The design is more size-efficient and includes an easy latch mechanism. The new covers also contain flash barriers to help protect against electrical flash overs. The covers are molded from high-impact polypropylene (UL94V-1) and are UL® listed, CSA certified to 600 V applications at 105 °C.

The soft shell covers include these features:

- **Size-efficient design**
Won't take up as much room in the enclosure or vault, easier to store and carry to the job site
- **Easy latch mechanism**
Quick but sturdy cover latch for optimum insulation
- **Flash barriers**
Provides protection from electrical flashovers
- **105 °C rating**
Offers maximum performance and higher than many competitors' temperature ratings
- **High-impact polypropylene**
Constructed from rugged materials for long-lasting protection

Also available in clear, impact-resistant and flame-retardant polycarbonate (UL94V-0). The clear version includes an internal pocket for a visible identification label without opening the cover. Contact Customer Service for shipping and availability.



01



02



03

Soft shell H-tap/C-tap covers



Cat. no.	For H-taps	For C-taps	Dimensions (in.)			Std. qty.
			A	B	C	
HTCV1	CHT814-10	54705, 54710, 54715	1 3/4	7/8	9/16	5
HTCV2	CHT214-9, CHT250214-8, CHT25014-7, CHT2502-6	54770, 54775, 54780	3 3/8	1 1/8	1	5
HTCV3	CHT50010-5, CHT50040-4	54740, 54745, 54750, 54755, 54760, 54765	3 27/32	1 5/8	1 5/16	5
HTCV4	CHT75010-3, CHT750350-2, CHT750350-1F, CHT75040-11	-	5 5/8	2	1 11/16	5
HTCV2CLRFR	CHT214-9, CHT250214-8, CHT25014-7, CHT2502-6	-	3 3/8	1 3/8	1	5

Diagrams

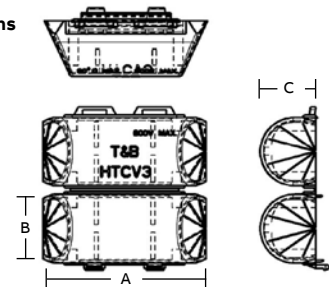

Wire joints for copper conductors

All-around compression ensures high conductivity, low resistance and high pull-out values exceeding CSA requirements



Compression wire joints for copper conductors

- Ideal for pigtailing, tapping multiple conductors or two-way splicing
- Form a permanent installation in minimal space
- Easily insulated
- Offer lowest installed cost
- Made of high-conductivity copper and electro tin-plated
- Colored-coded to dies for positive matching and compression

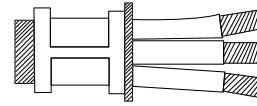

Pigtail

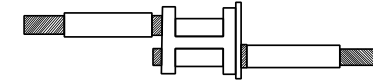

Two-way connector

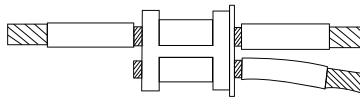

Three-way connector

AWG Size	Circular Mil Area
#14	4,107
#12	6,530
#10	10,380
#8	16,510
#6	26,250
#4	41,740
#2	66,370
#1	83,690
1/0	105,500
2/0	133,100
3/0	167,800
4/0	211,600



Compression wire joints for copper conductors

Cat. no.	Circular mil area		Cable combination (AWG)		Dimensions (in.) mm		Colour code	Installing hand tools					
	Min.	Max.	Min.	Max.	A	E		TBM25S/21E	TBM45S	TBM8/8S	TBM5/5S	TBM6 & TBM6S	
								Die cat. no.	Die cat. no.	Die cat. no.	Upper	Lower	
54610	19,590	27,290	(3) #12 sol. or str.	(2) #10 w/(1) #12 sol. or str.	0.407 (10.3)	0.370 (9.4)	Blue	Included	-	-	-	13475	13477
54615	31,140	43,400	(3) #10 sol. or str.	(4) #10 sol. or str.	0.407 (10.3)	0.430 (10.9)	Grey	Included	13461	13454	13472	13476	-
54620	49,530	65,560	(3) #8 sol. or str.	(1) #4 w/(2) #10 sol. or str.	0.417 (10.6)	0.475 (12.1)	Brown	Included	-	-	13474	-	-
54625-TB	66,040	87,130	(4) #8 sol. or str.	(1) #2 str w/(2) #12 sol. or str.	0.479 (12.2)	0.545 (13.8)	Green	-	-	-	-	-	-
54630	83,480	99,990	(2) #4 sol. or str.	(2) #4 w/(1) #10 sol. or str.	0.479 (12.2)	0.585 (14.9)	Pink	-	13462	13455	13475	13477	-
54635	99,060	124,220	(6) #8 str.	(2) #4 w/(2) #8 sol. or str.	0.762 (19.4)	0.620 (15.7)	Black	-	-	-	13474	-	-
54640	125,220	166,120	(3) #4 sol. or str.	(3) #4 w/(2) #10 sol. or str.	0.762 (19.4)	0.695 (17.7)	Orange	-	-	-	-	-	-
54645-TB	166,960	193,630	(4) #4 sol. or str.	(2) #1 w/(2) #10 sol. or str.	0.824 (20.9)	0.770 (19.6)	Purple	-	13463	13456	13475	-	-
54650	189,190	244,020	(3) #2 str.	(2) #1/0 w/(2) #8 str.	0.887 (22.5)	0.830 (21.1)	Yellow	-	13463	13456	13473	13476	-

Diagrams

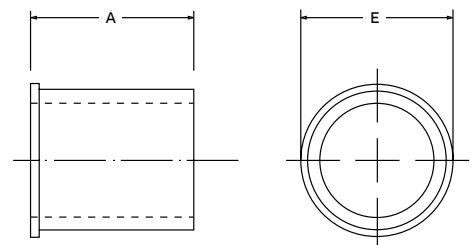

Hand tools only.
For tool and die selection charts, see the section E31-E48 of the Tools, Dies and Kits catalogue.

Cast copper bus taps for copper conductors

Clamps onto bus bar — no drilling required



Heavy-duty bus bar taps – certified to 600 V and recommended up to 35 kV^v applications

Material – High-conductivity cast copper alloy

Finish – Electro tin plated

Contact material – Beryllium copper

- For bus bars up to ¼ in. thick, 3–6 in. wide and code copper cable
- Take up less than 1¼ in. of bus bar space
- Convex shape of connector tongue exerts great contact pressure on bus bar
- Install with hydraulic tools and hex crimp dies

Heavy-duty bus bar taps – Certified to 600 V and recommended up to 35 kV^v applications

Cat. no.	Wire size (AWG or kcmil)		Fig. no.	Busbar width	Dimensions in. (mm)			Die code
	Code cable	Flex			A	B	C	
251-31446-1	1/0	225/24	1	3	6.12 (155.4)	2.28 (57.9)	3.50 (88.9)	66H
251-31446-7	1/0	225/24	1	4	7.12 (180.8)	2.28 (57.9)	4.50 (114.3)	66H
251-31446-13	1/0	225/24	2	5 or 6	9.12 (231.6)	2.28 (57.9)	6.38 (162.1)	66H
251-31446-8	2/0	1/0, 275/24	1	4	7.12 (180.8)	2.28 (57.9)	4.50 (114.3)	66H
251-31446-14	2/0	1/0, 275/24	2	5 or 6	9.12 (231.6)	2.28 (57.9)	6.38 (162.1)	66H
251-31446-23	4/0	450/24	1	3	6.12 (155.4)	2.28 (57.9)	3.50 (88.9)	66H
251-31446-22	4/0	450/24	1	4	7.12 (180.8)	2.28 (57.9)	4.50 (114.3)	66H
251-31446-19	4/0	450/24	2	6	9.12 (231.6)	2.28 (57.9)	6.44 (163.6)	66H
251-31446-29	250	4/0, 550/24	1	3	5.68 (144.3)	2.28 (57.9)	3.38 (85.9)	66H
251-31446-30	250	4/0, 550/24	1	4	7.12 (180.8)	2.28 (57.9)	4.50 (114.3)	66H
251-31446-31	250	4/0, 550/24	1	5 or 6	9.12 (231.6)	2.28 (57.9)	6.38 (162.1)	66H
251-31446-3	350	–	1	3	6.63 (168.4)	2.56 (65.0)	3.50 (88.9)	99H
251-31446-9	350	–	1	4	7.63 (193.8)	2.56 (65.0)	4.50 (114.3)	99H
251-31446-15	350	–	2	5 or 6	9.63 (244.6)	2.56 (65.0)	6.38 (162.1)	99H
251-31446-4	500	350, 925/24	1	3	6.63 (168.4)	2.56 (65.0)	3.50 (88.9)	99H
251-31446-10	500	350, 925/24	1	4	7.63 (193.8)	2.56 (65.0)	4.50 (114.3)	99H
251-31446-16	500	350, 925/24	2	5 or 6	9.63 (244.6)	2.56 (65.0)	6.38 (162.1)	99H
251-31446-17	600	–	2	5 or 6	9.75 (247.7)	2.75 (69.9)	6.38 (162.1)	112H
251-31446-21	700	–	1	6	9.75 (247.7)	2.75 (69.9)	6.44 (163.6)	112H
251-31446-6	750	500, 1,325/24	1	3	6.75 (171.5)	2.75 (69.9)	3.50 (88.9)	112H
251-31446-12	750	500, 1,325/24	2	4	7.75 (196.6)	2.75 (69.9)	4.50 (114.3)	112H
251-31446-18	750	500, 1,325/24	2	5 or 6	9.75 (247.7)	2.75 (69.9)	6.38 (162.1)	112H
251-31446-36	–	750, 1,925/24	2	5 or 6	9.75 (247.7)	2.75 (69.9)	6.44 (163.6)	112H

Diagrams

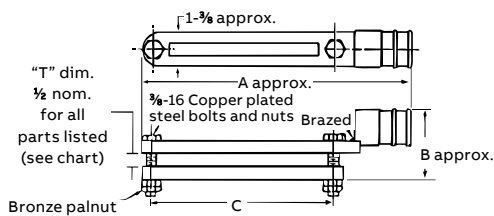

Figure 1

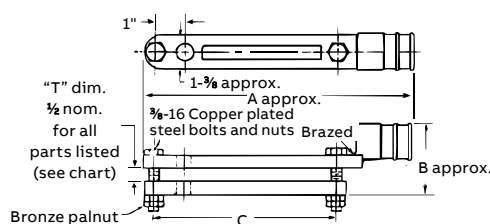
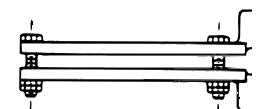

Figure 2



Double cable—Use AD suffix

Styles shown have cable tap on one portion of clamp assembly. Clamp assemblies with cable taps on both portions (top and bottom identical) are also available.

These assemblies are identified by adding suffix "AD" to catalogue numbers shown (example: 251-31446-1AD).

Only one hydraulic tools with hex crimp dies TBM12.

* For installations from 16 kV up to 35 kV, consult shielded cable manufacturers for stress relief and insulation requirements.

For tool and die selection charts, see the section E31-E48 of the Tools, Dies and Kits catalogue.

Motor pigtail connectors

Quick, reliable change-out of electric motors with no bolting, taping or loose connections



One line to one load (two wires)

- Complete line of motor lead disconnects for 600 V and 5 kV applications, covering wire range from #16 through 4/0 AWG
- Fast, snap-together assembly offers maximum labor savings
- No need for nuts, bolts and washers or insulating tape – simply slide on reusable boot
- Total assembly fits into tight motor housings
- Quick disconnect – no knife cutting of melted tape, eliminating the risk of accidental cutting of wire insulation, resulting motor downtime and installer exposure

- Meet or exceed electrical and mechanical performance of bolted connections
- Constructed of high-conductivity copper with tin-plating
- Female disconnects equipped with beryllium copper interface band for dependable connections



One line to one load (two wires)

Cat. no. certified to 600 V		Wire size (AWG or kcmil)	Body size	Colour code	Boot insulation	Dimensions in. (mm)						Strip length (in.)
Female disconnect	Male disconnect					A	B	C	D	E	F	
MD1614F-0	MD1614M-0	#16-14	0	Blue	MDBOOT-0	0.25 (6.4)	0.25 (6.4)	0.63 (16.0)	0.52 (13.2)	0.25 (6.4)	0.13 (3.2)	3/8
MD1614F-1	MD1614M-1	#16-14	1	Blue	MDBOOT-1	0.38 (9.7)	0.38 (9.7)	0.78 (19.8)	0.75 (19.1)	0.38 (9.7)	0.25 (6.4)	3/8
MD1210F-1	MD1210M-1	#12-10	1	Yellow	MDBOOT-1	0.38 (9.7)	0.35 (8.9)	0.78 (19.8)	0.75 (19.1)	0.38 (9.7)	0.25 (6.4)	3/8
MD1210F-2	MD1210M-2	#12-10	2	Yellow	MDBOOT-2	0.50 (12.7)	0.50 (12.7)	0.90 (22.9)	1.00 (25.4)	0.50 (12.7)	0.37 (9.4)	3/8
MD8F-1	MD8M-1	#8	1	Red	MDBOOT-1	0.38 (9.7)	0.38 (9.7)	0.82 (20.8)	0.75 (19.1)	0.38 (9.7)	0.25 (6.4)	7/16
MD8F-2	MD8M-2	#8	2	Red	MDBOOT-2	0.50 (12.7)	0.50 (12.7)	0.95 (24.1)	1.00 (25.4)	0.50 (12.7)	0.37 (9.4)	7/16
MD6F-1	MD6M-1	#6	1	Blue	MDBOOT-1	0.38 (9.7)	0.38 (9.7)	0.88 (22.4)	0.75 (19.1)	0.38 (9.7)	0.25 (6.4)	1/2
MD6F-2	MD6M-2	#6	2	Blue	MDBOOT-2	0.50 (12.7)	0.50 (12.7)	1.02 (30.5)	1.00 (25.4)	0.50 (12.7)	0.37 (9.4)	1/2
MD4F-2	MD4M-2	#4	2	Grey	MDBOOT-2	0.50 (12.7)	0.50 (12.7)	1.03 (40.6)	1.00 (25.4)	0.50 (12.7)	0.37 (9.4)	1/2
MD2F-2	MD2M-2	#2	2	Brown	MDBOOT-2	0.50 (12.7)	0.50 (12.7)	1.09 (48.3)	1.00 (25.4)	0.50 (12.7)	0.37 (9.4)	17/32
MD2F-3	MD2M-3	#2	3	Brown	MDBOOT-3	0.88 (22.4)	0.88 (22.4)	1.46 (37.1)	1.75 (44.5)	0.88 (22.4)	0.50 (12.7)	17/32
MD1F-2	MD1M-2	#1	2	Green	MDBOOT-2	0.50 (12.7)	0.50 (12.7)	1.23 (31.2)	1.00 (25.4)	0.50 (12.7)	0.37 (9.4)	9/16
MD1F-3	MD1M-3	#1	3	Green	MDBOOT-3	0.88 (22.4)	0.88 (22.4)	1.56 (39.6)	1.75 (44.5)	0.88 (22.4)	0.50 (12.7)	9/16
MD10F-3	MD10M-3	1/0	3	Pink	MDBOOT-3	0.88 (22.4)	0.88 (22.4)	1.56 (39.6)	1.75 (44.5)	0.88 (22.4)	0.50 (12.7)	9/16
MD20F-3	MD20M-3	2/0	3	Black	MDBOOT-3	0.88 (22.4)	0.88 (22.4)	1.59 (40.4)	1.75 (44.5)	0.88 (22.4)	0.50 (12.7)	5/8
MD30F-3	MD30M-3	3/0	3	Orange	MDBOOT-3	0.88 (22.4)	0.88 (22.4)	1.71 (43.4)	1.75 (44.5)	0.88 (22.4)	0.50 (12.7)	11/16
MD40F-3	MD40M-3	4/0	3	Purple	MDBOOT-3	0.88 (22.4)	0.88 (22.4)	1.81 (46.0)	1.75 (44.5)	0.88 (22.4)	0.50 (12.7)	3/4
MD40F-4	MD40M-4	4/0	4	Purple	MDBOOT-4	1.25 (31.8)	1.25 (31.8)	2.89 (73.4)	2.69 (68.3)	1.25 (31.8)	0.81 (22.4)	-
MD250F-4	MD250M-4	250	4	Yellow	MDBOOT-4	1.25 (31.8)	1.25 (31.8)	2.89 (73.4)	2.69 (68.3)	1.25 (31.8)	0.81 (22.4)	-
MD350F-4	MD350M-4	350	4	Red	MDBOOT-4	1.25 (31.8)	1.25 (31.8)	2.89 (73.4)	2.69 (68.3)	1.25 (31.8)	0.81 (22.4)	-
MD500F-4	MD500M-4	500	4	Brown	MDBOOT-4	1.25 (31.8)	1.25 (31.8)	2.89 (73.4)	2.69 (68.3)	1.25 (31.8)	0.81 (22.4)	-

Diagrams

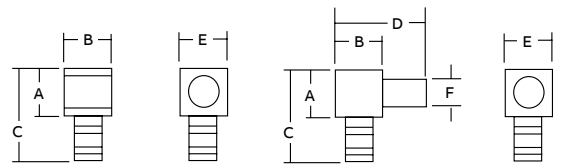

Female disconnect

Male disconnect

Motor pigtail connectors

Quick, easy installation



600 V version

5 kV version

One line to one load (two wires) (continued)

- 1) Choose appropriate Color-Keyed disconnect for conductor size to be terminated. Note color of bands on disconnect barrel.
- 2) Select proper installing die by matching die color to disconnect barrel color bands.
- 3) Install die in ABB tool, insert stripped wire into barrel of disconnect and compress between color bands. Repeat for mating half.
- 4) Snap the two halves together and slip on insulator over mated connection. Secure insulator with Ty-Rap® cable ties provided with the insulators.

Material – High-conductivity cast copper

Plating – Electro tin plated

Insulator – Thermoplastic elastomer

Contact Material – Beryllium Copper



One line to one load (two wires) (continued)

Cat. no. certified to 600 V		Installing tools							
Female disconnect	Male disconnect	WT112M WT111M WT2000 ERG4002 ERG4005	TBM45S	TBM6, TBM6S		TBM5, TBM5S	TBM8, TBM8S	Hydraulic tools	
				Upper die	Lower die	Die set	Die set	Die code	Colour code
MD1614F-0	MD1614M-0	X	-	-	-	-	-	-	-
MD1614F-1	MD1614M-1	X	-	-	-	-	-	-	-
MD1210F-1	MD1210M-1	X	-	-	-	-	-	-	-
MD1210F-2	MD1210M-2	X	-	-	-	-	-	-	-
MD8F-1	MD8M-1	-	X	13475	13477	13454	13461	21	Red
MD8F-2	MD8M-2	-	X	13475	13477	13454	13461	21	Red
MD6F-1	MD6M-1	-	X	13475	13477	13454	13461	24	Blue
MD6F-2	MD6M-2	-	X	13475	13477	13454	13461	24	Blue
MD4F-2	MD4M-2	-	X	13472	13476	13454	13461	29	Grey
MD2F-2	MD2M-2	-	X	13474	13477	13454	13461	33	Brown
MD2F-3	MD2M-3	-	X	13474	13477	13454	13461	33	Brown
MD1F-2	MD1M-2	-	-	13474	13477	13455	13462	37	Green
MD1F-3	MD1M-3	-	-	13474	13477	13455	13462	37	Green
MD10F-3	MD10M-3	-	-	13475	13477	13455	13462	42	Pink
MD20F-3	MD20M-3	-	-	13474	13477	13455	13462	45	Black
MD30F-3	MD30M-3	-	-	13474	13477	13455	13462	50	Orange
MD40F-3	MD40M-3	-	-	13475	13477	13456	13463	54	Purple

Specifications:

Wire range: #16 to 4/0 AWG.

Rating: 600 V, 90 °C.

For tool and die selection charts, see the section E31-E48 of the Tools, Dies and Kits catalogue.

Motor pigtail connectors



One line to two load (three wires)

- KON-TOUR™ louvered contact bands
- Colour-coded to match installing dies

Material – High-conductivity wrought copper

Finish – Electro tin plated

Contact material – Beryllium copper



One line to two load (three wires)

Cat. no. certified to 600 V

Female disconnect	Male disconnect	Wire size (AWG)	Body size	Colour code	Boot insulation	Dimensions in. (mm)						Strip length (in.)
						A	B	C	D	E	F	
MD1614F-0	M2D1614M-0	#16–14 AWG	0	Blue	MDBOOT-0	0.25 (6.4)	0.25 (6.4)	0.63 (16.0)	0.52 (13.2)	0.25 (6.4)	0.13 (3.3)	3/8
MD1614F-1	M2D1614M-1	#16–14 AWG	1	Blue	MDBOOT-1	0.38 (9.7)	0.38 (9.7)	0.78 (19.8)	0.75 (19.1)	0.38 (9.7)	0.25 (6.4)	3/8
MD1210F-1	M2D1210M-1	#12–10 AWG	1	Yellow	M2DBOOT-1	0.38 (9.7)	0.35 (8.9)	0.78 (19.8)	0.75 (19.1)	0.38 (9.7)	0.25 (6.4)	3/8
MD1210F-2	M2D1210M-2	#12–10 AWG	2	Yellow	M2DBOOT-2	0.50 (12.7)	0.50 (12.7)	0.90 (22.9)	1.00 (25.4)	0.50 (12.7)	0.37 (9.4)	3/8
MD8F-1	M2D8M-1	#8 AWG	1	Red	M2DBOOT-1	0.38 (9.7)	0.38 (9.7)	0.82 (20.8)	0.75 (19.1)	0.38 (9.7)	0.25 (6.4)	7/16
MD8F-2	M2D8M-2	#8 AWG	2	Red	M2DBOOT-2	0.50 (12.7)	0.50 (12.7)	0.95 (24.1)	1.00 (25.4)	0.50 (12.7)	0.37 (9.4)	7/16
MD6F-1	M2D6M-1	#6 AWG	1	Blue	M2DBOOT-1	0.38 (9.7)	0.38 (9.7)	0.88 (22.4)	0.75 (19.1)	0.38 (9.7)	0.25 (6.4)	1/2
MD6F-2	M2D6M-2	#6 AWG	2	Blue	M2DBOOT-2	0.50 (12.7)	0.50 (12.7)	1.02 (25.9)	1.00 (25.4)	0.50 (12.7)	0.37 (9.4)	1/2
MD4F-2	M2D4M-2	#4 AWG	2	Grey	M2DBOOT-2	0.50 (12.7)	0.50 (12.7)	1.03 (26.2)	1.00 (25.4)	0.50 (12.7)	0.37 (9.4)	1/2
MD2F-2	M2D2M-2	#2 AWG	2	Brown	M2DBOOT-2	0.50 (12.7)	0.50 (12.7)	1.09 (27.7)	1.00 (25.4)	0.50 (12.7)	0.37 (9.4)	17/32
MD2F-3	M2D2M-3	#2 AWG	3	Brown	M2DBOOT-3	0.88 (22.4)	0.88 (22.4)	1.46 (37.1)	1.75 (44.5)	0.88 (22.4)	0.50 (12.7)	17/32
MD1F-2	M2D1M-2	#1 AWG	2	Green	M2DBOOT-2	0.50 (12.7)	0.50 (12.7)	1.23 (31.2)	1.00 (25.4)	0.50 (12.7)	0.37 (9.4)	9/16
MD1F-3	M2D1M-3	#1 AWG	3	Green	M2DBOOT-3	0.88 (22.4)	0.88 (22.4)	1.56 (39.6)	1.75 (44.5)	0.88 (22.4)	0.50 (12.7)	9/16
MD10F-3	M2D10M-3	1/0 AWG	3	Pink	M2DBOOT-3	0.88 (22.4)	0.88 (22.4)	1.56 (39.6)	1.75 (44.5)	0.88 (22.4)	0.50 (12.7)	9/16
MD20F-3	M2D20M-3	2/0 AWG	3	Black	M2DBOOT-3	0.88 (22.4)	0.88 (22.4)	1.59 (40.4)	1.75 (44.5)	0.88 (22.4)	0.50 (12.7)	5/8
MD30F-3	M2D30M-3	3/0 AWG	3	Orange	M2DBOOT-3	0.88 (22.4)	0.88 (22.4)	1.71 (43.4)	1.75 (44.5)	0.88 (22.4)	0.50 (12.7)	11/16
MD40F-3	M2D40M-3	4/0 AWG	3	Purple	M2DBOOT-3	0.88 (22.4)	0.88 (22.4)	1.81 (46.0)	1.75 (44.5)	0.88 (22.4)	0.50 (12.7)	3/4

Diagrams

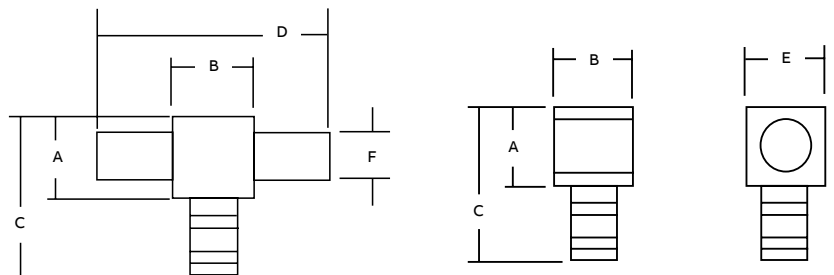

Operating range: 600 V max., 1000 V max. in signs and fixtures.

Listing: UL listed and CSA certified for 12/8 AWG solid copper conductors and stranded copper conductors in the sizes shown.

Selection: Always use the same body size when selecting male and female disconnects.

For example: to connect a 2 AWG male to an #8 AWG female, select cat. no. M2DM-2 and MD8F-2. Both have body size 2.

Insulation: Use insulating boots matching the disconnect body size as indicated in the chart.

To protect the connection from moisture and dirt, use sealing compound cat. no. MDBOOT-SEAL.

For tool and die selection charts, see the section E31-E48 of the Tools, Dies and Kits catalogue.

Motor pigtail connectors



5 kV motor pigtail connectors supplied with boot, pin, silicon gel (two female connectors required)*

Diagrams	Cat. no.	Wire range (AWG)	Female disconnect Cat. no.	Colour code	Dimensions in. (mm)			Body size
					L	W	H	
	5KVBOOT-2L (connection pin for two female connectors included)	#8	MD8F-2	Red	4.50 (114.3)	2.25 (57.2)	1.44 (36.6)	2
		#6	MD6F-2	Blue	4.50 (114.3)	2.25 (57.2)	1.44 (36.6)	2
		#4	MD4F-2	Grey	4.50 (114.3)	2.25 (57.2)	1.44 (36.6)	2
		#2	MD2F-2	Brown	4.50 (114.3)	2.25 (57.2)	1.44 (36.6)	2
		#1	MD1F-2	Green	4.50 (114.3)	2.25 (57.2)	1.44 (36.6)	2
	5KVBOOT-3L (connection pin for two female connectors included)	#2	MD2F-3	Brown	4.50 (114.3)	2.25 (57.2)	1.44 (36.6)	3
		#1	MD1F-3	Green	4.50 (114.3)	2.25 (57.2)	1.44 (36.6)	3
		1/0	MD10F-3	Pink	4.50 (114.3)	2.25 (57.2)	1.44 (36.6)	3
		2/0	MD20F-3	Black	4.50 (114.3)	2.25 (57.2)	1.44 (36.6)	3
		3/0	MD30F-3	Orange	4.50 (114.3)	2.25 (57.2)	1.44 (36.6)	3
		4/0	MD40F-3	Purple	4.50 (114.3)	2.25 (57.2)	1.44 (36.6)	3

CSA and UL non applicable.

* Male pin supplied will fit all ranges and combinations of wire sizes per body size.



Sealing for motor-disconnect boots

Sealant should be used with ABB motor-disconnect boots: MDBOOT-O, MDBOOT-1, MDBOOT-2 and MDBOOT-3. The cable should be clean and free of grease and other foreign substances. Apply two layers around each cable at the same distance from the connector. Slide the assembly into boot, apply Ty-Rap cable ties and work sealant around wires at end of boot to eliminate voids.

Technical specifications

- Description: polybutene compound
- Application temperature: 4 °C to 38 °C (40 °F to 100 °F)
- Service temperature: -40 °C to 82 °C (-40 °F to 180 °F)
- Dimensions: width 1 in., thickness 1/8 in., length (std. roll) 10 ft., wrapped on release liner
- Environmental resistance: resists normal aging process
- Chemical resistance: resists acids, bases and alcohols
- Dielectric strength: 200 V/mil minimum
- Volume resistivity: 1013 ohms/cm
- Flame retardancy: passed VO vertical flame test

Sealing for motor-disconnect boots

Diagrams	Cat. no.	Description
	MDBOOT-SEAL	Sealant

For watertight applications, consult your Regional Sales Office for informations.



Silicone lubricant for high voltage electrical work

Cat. no.	Size	Std. pkg.
2015	5 grams	100 envelopes
SL5	5 oz./142 grams	12 tubes

KUBE flag and tee connectors

A cost-saving breakthrough in 90° and T-connections



Flag and tee connectors

Finally there's a fast, easy and affordable way to make those 90° and T electrical connections whenever and wherever you need them. Color-Keyed flags and tees are designed — and CSA/UL approved — to be used with standard Color-Keyed lugs and splices from #8 through 4/0 AWG in field-assembled configurations. Now you don't need to use high-cost flexible conductor for connections requiring 90° bending radius or expensive brazed or welded connectors for T connections. Insulated with custom-fit, halogen-free polypropylene for safety and performance, Color-Keyed flags and tees are available in bulk quantities for OEM applications and in a convenient kit for field use.

- Offers lowest installed cost for the application
- Versatile, modular design enables thousands of field-constructible connection possibilities, including multi-circuit configurations
- CSA certified and UL listed for field installation
- Insulated for fast, safe termination and installation
- Used with standard Color-Keyed lugs and splices
- Colour coded for easy selection of correct crimping die and easy certification of proper crimp
- Constructed from high-conductivity, low-resistance 99.9% pure wrought copper for optimum electrical performance
- Tin-plated for corrosion resistance and excellent contact

Technical specifications

- Connector: tin-plated copper
- Insulation: halogen-free polypropylene
- Standards: CSA Certified and UL Listed



Cat. no.	Wire size (AWG)	Insulator	Std. pkg. qty.
Flags			
FLAG1614	#16-#14	F-INSUL-0	20
FLAG1210	#12-#10	F-INSUL-0	10
FLAG8	#8	F-INSUL-1	10
FLAG6	#6	F-INSUL-1	10
FLAG4	#4	F-INSUL-2	6
FLAG2	#2	F-INSUL-2	6
FLAG1	#1	F-INSUL-2	6
FLAG10	1/0	F-INSUL-3	3
FLAG20	2/0	F-INSUL-3	3
FLAG30	3/0	F-INSUL-3	3
FLAG40	4/0	F-INSUL-3	3

Cat. no.	Wire size (AWG)	Insulator	Std. pkg. qty.
Tees			
TEE1614	#16-#14	-	20
TEE1210	#12-#10	-	10
TEE8	#8	-	10
TEE6	#6	-	10
TEE4	#4	-	6
TEE2	#2	-	6
TEE1	#1	-	6
TEE10	1/0	-	3
TEE20	2/0	-	3
TEE30	3/0	-	3
TEE40	4/0	-	3

KUBE flag and tee connectors



Make on-site custom electrical connections in:

- 90° lugs (lugs can rotate 360°)
- 90° splices
- T-lugs
- T-splices
- Countless connection possibilities using any straight or angled lug from 15° to 90° (lugs can rotate 360° for easy positioning)

Cat. no.	Wire size (AWG)	Std. pkg. qty.
Flag insulators		
F-INSUL-0	For #16–10 AWG	20/200
F-INSUL-1	For #8, #6 AWG	10/100
F-INSUL-2	For #4, #2, #1 AWG	6/60
F-INSUL-3	For 1/0, 2/0, 3/0, 4/0 AWG	3/30



Flag and tee kit contents:

- Steel carrying case
- TBM45S crimp tool
- 25 each #8, #6 and #4 AWG flag bodies
- 25 each #8, #6 and #4 AWG one-hole lugs
- 10 each #2, #1, 1/0, 2/0, 3/0 and 4/0 AWG flag bodies
- 10 each #2, #1, 1/0, 2/0, 3/0 and 4/0 AWG one-hole lugs
- 50 size 1 flag insulators
- 45 size 2 flag insulators
- 40 size 3 flag insulators
- 10 each #8 and #6 AWG tee bodies
- 20 each #8 and #6 AWG two-way splices
- 6 each #4, #2 and #1 AWG tee bodies
- 12 each #4, #2 and #1 AWG two-way splices
- 3 each 1/0, 2/0, 3/0 and 4/0 AWG tee bodies
- 6 each 1/0, 2/0, 3/0 and 4/0 AWG two-way splices

Cat. no.	Description	Std. pkg. qty.
FLAGTEEKIT	Flag and tee kit	1

Connectors for aluminum/copper code conductors

Designed and approved for use with both aluminum and copper conductors



One-hole lugs

- For 90 °C certified to 600 V and recommended up to 35 kV[†] applications
- Easily matched to the correct Color-Keyed installing die for positive compressions
- Hardened steel dies compress connector around cable, changing round strands to polygonal shapes and cold flowing strands and connector into a solid, homogenous mass

- Long compression areas ensure complete contact
- Multiple compressions prevent creep of aluminum conductors
- Filled with high-temperature oxide-inhibitor compound
- Electro tin plating prevents electrolytic corrosion of copper to ensure lowest contact resistance

Material – High-conductivity wrought aluminum

Finish – Electro tin plated



One-hole lugs[†]

Cat no.	Cable size Al-Cu (AWG or kcmil)	Bolt size	Dimensions in. (mm)						Die code	Colour code
			A	B	C	D	E	F		
60096	#10	#10	1.09 (27.7)	0.56 (14.2)	0.41 (10.4)	0.06 (1.5)	0.27 (6.9)	0.22 (5.6)	21	Red
60097	#10	¼	1.31 (33.3)	0.72 (18.3)	0.43 (10.9)	0.07 (1.8)	0.27 (6.9)	0.34 (8.6)	21	Red
60099	#10	⅜	1.53 (38.9)	0.93 (23.6)	0.58 (14.7)	0.06 (1.5)	0.27 (6.9)	0.44 (11.2)	21	Red
60101-TB	#8	#10	1.22 (31.0)	0.56 (14.2)	0.41 (10.4)	0.09 (2.3)	0.28 (7.1)	0.22 (5.6)	24	Blue
60102-TB	#8	¼	1.38 (35.1)	0.71 (18.0)	0.44 (11.2)	0.09 (2.3)	0.28 (7.1)	0.34 (8.6)	24	Blue
60103-TB	#8	⅜	1.56 (39.6)	0.91 (23.1)	0.60 (15.2)	0.06 (1.5)	0.28 (7.1)	0.44 (11.2)	24	Blue
60104-TB	#8	⅜	1.60 (40.6)	0.93 (23.6)	0.60 (15.2)	0.06 (1.5)	0.28 (7.1)	0.44 (11.2)	24	Blue
60106-TB	#6	#10	1.52 (38.6)	0.59 (15.0)	0.47 (11.9)	0.13 (3.3)	0.35 (8.9)	0.22 (5.6)	29	Grey
60107-TB	#6	¼	1.67 (42.4)	0.75 (19.1)	0.47 (11.9)	0.13 (3.3)	0.35 (8.9)	0.34 (8.6)	29	Grey
60108-TB	#6	⅜	1.83 (46.5)	0.91 (23.1)	0.63 (16.0)	0.09 (2.3)	0.35 (8.9)	0.44 (11.2)	29	Grey
60109-TB	#6	⅜	1.86 (47.2)	0.93 (23.6)	0.63 (16.0)	0.09 (2.3)	0.35 (8.9)	0.44 (11.2)	29	Grey
60112-TB	#4	¼	1.81 (46.0)	0.75 (19.1)	0.64 (16.3)	0.19 (4.8)	0.46 (11.7)	0.34 (8.6)	37	Green
60113-TB	#4	⅜	2.00 (50.8)	0.91 (23.1)	0.64 (16.3)	0.19 (4.8)	0.46 (11.7)	0.44 (11.2)	37	Green
60114-TB	#4	⅜	2.03 (51.6)	0.93 (23.6)	0.64 (16.3)	0.19 (4.8)	0.46 (11.7)	0.44 (11.2)	37	Green
60116-TB	#2	¼	1.91 (48.5)	0.75 (19.1)	0.72 (18.3)	0.19 (4.8)	0.51 (13.0)	0.34 (8.6)	42	Pink
60117-TB	#2	⅜	2.06 (52.3)	0.91 (23.1)	0.72 (18.3)	0.19 (4.8)	0.51 (13.0)	0.44 (11.2)	42	Pink
60118-TB	#2	⅜	2.09 (53.1)	0.93 (23.6)	0.72 (18.3)	0.19 (4.8)	0.51 (13.0)	0.44 (11.2)	42	Pink
60120	#2	½	2.25 (57.2)	1.41 (35.8)	0.88 (22.4)	0.19 (4.8)	0.51 (13.0)	0.69 (17.5)	42	Pink
60122	#1	¼	2.30 (58.4)	0.81 (20.6)	0.75 (19.1)	0.19 (4.8)	0.56 (14.2)	0.34 (8.6)	45	Gold
60123	#1	⅜	2.39 (60.7)	0.91 (23.1)	0.75 (19.1)	0.19 (4.8)	0.56 (14.2)	0.44 (11.2)	45	Gold
60124	#1	⅜	2.42 (61.5)	0.93 (23.6)	0.75 (19.1)	0.19 (4.8)	0.56 (14.2)	0.44 (11.2)	45	Gold
60126	#1	½	2.89 (73.4)	1.41 (35.8)	0.88 (22.4)	0.16 (4.1)	0.56 (14.2)	0.69 (17.5)	45	Gold
60128	1/0	¼	2.36 (59.9)	0.81 (20.6)	0.88 (22.4)	0.19 (4.8)	0.62 (15.7)	0.34 (8.6)	50	Tan
60129	1/0	⅜	2.51 (63.8)	0.97 (24.6)	0.88 (22.4)	0.19 (4.8)	0.62 (15.7)	0.44 (11.2)	50	Tan
60130	1/0	⅜	2.51 (63.8)	0.97 (24.6)	0.88 (22.4)	0.19 (4.8)	0.62 (15.7)	0.44 (11.2)	50	Tan
60132	1/0	½	2.95 (74.9)	1.41 (35.8)	0.94 (23.9)	0.19 (4.8)	0.62 (15.7)	0.69 (17.5)	50	Tan

Diagram

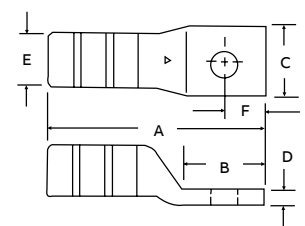

[†] For installations from 16 kV up to 35 kV, consult shielded cable manufacturers for stress relief and insulation requirements. Call your regional sales office for sizes not listed. For tool and die selection charts, see the section E31-E48 of the Tools, Dies and Kits catalogue.

Connectors for aluminum/copper code conductors

Designed and approved for use with both aluminum and copper conductors



Material – High-conductivity wrought aluminum

Finish – Electro tin plated



One-hole lugs[†] (continued)

Cat no.	Cable size Al-Cu (AWG or kcmil)	Bolt size	Dimensions in. (mm)						Die code	Colour code
			A	B	C	D	E	F		
60134	2/0	¼	2.48 (63.0)	0.87 (22.1)	0.97 (24.6)	0.22 (5.6)	0.70 (17.8)	0.34 (8.6)	54	Olive
60135	2/0	⅝	2.64 (67.1)	1.03 (26.2)	0.97 (24.6)	0.22 (5.6)	0.70 (17.8)	0.44 (11.2)	54	
60136	2/0	¾	2.64 (67.1)	1.03 (26.2)	0.97 (24.6)	0.22 (5.6)	0.70 (17.8)	0.44 (11.2)	54	
60138	2/0	½	3.10 (78.7)	1.41 (35.8)	1.03 (26.2)	0.22 (5.6)	0.70 (17.8)	0.69 (17.5)	54	
60140	3/0	¼	2.58 (65.5)	0.87 (22.1)	1.06 (26.9)	0.22 (5.6)	0.77 (19.6)	0.34 (8.6)	60	Ruby
60141	3/0	⅝	2.83 (71.9)	1.09 (27.7)	1.06 (26.9)	0.22 (5.6)	0.77 (19.6)	0.44 (11.2)	60	
60142	3/0	¾	2.83 (71.9)	1.09 (27.7)	1.06 (26.9)	0.22 (5.6)	0.77 (19.6)	0.44 (11.2)	60	
60144	3/0	½	3.15 (80.0)	1.41 (35.8)	1.06 (26.9)	0.22 (5.6)	0.77 (19.6)	0.69 (17.5)	60	
60147	4/0	⅝	3.53 (89.7)	0.88 (22.4)	1.21 (30.7)	0.25 (6.4)	0.86 (21.8)	0.38 (9.7)	66	White
60148	4/0	¾	3.59 (91.2)	0.93 (23.6)	1.21 (30.7)	0.25 (6.4)	0.86 (21.8)	0.38 (9.7)	66	
60150	4/0	½	3.90 (99.1)	1.25 (31.8)	1.21 (30.7)	0.25 (6.4)	0.86 (21.8)	0.50 (12.7)	66	
60151	4/0	⅝	4.65 (118.1)	2.00 (50.8)	1.21 (30.7)	0.25 (6.4)	0.86 (21.8)	0.75 (19.0)	66	
60154	250	¾	3.73 (94.7)	0.93 (23.6)	1.29 (32.8)	0.27 (6.9)	0.92 (23.4)	0.38 (9.7)	71	Red
60156	250	½	4.05 (102.9)	1.25 (31.8)	1.29 (32.8)	0.27 (6.9)	0.92 (23.4)	0.50 (12.7)	71	
60157	250	⅝	4.80 (121.9)	2.00 (50.8)	1.29 (32.8)	0.27 (6.9)	0.92 (23.4)	0.75 (19.0)	71	
60159	300	⅝	3.75 (95.3)	0.88 (22.4)	1.39 (35.3)	0.28 (7.1)	0.99 (25.1)	0.38 (9.7)	76	Blue
60160	300	¾	3.80 (96.5)	0.93 (23.6)	1.39 (35.3)	0.28 (7.1)	0.99 (25.1)	0.38 (9.7)	76	
60162	300	½	4.13 (104.9)	1.25 (31.8)	1.39 (35.3)	0.28 (7.1)	0.99 (25.1)	0.50 (12.7)	76	
60165	350	½	4.83 (122.7)	1.25 (31.8)	1.53 (38.9)	0.33 (8.4)	1.09 (27.7)	0.50 (12.7)	87	Brown
60166	350	⅝	5.58 (141.7)	2.00 (50.8)	1.53 (38.9)	0.33 (8.4)	1.09 (27.7)	0.75 (19.0)	87	
60168	400	½	4.95 (125.7)	1.25 (31.8)	1.65 (41.9)	0.38 (9.7)	1.18 (30.0)	0.50 (12.7)	94	Green
60171	500	½	4.95 (125.7)	1.25 (31.8)	1.79 (45.5)	0.38 (9.7)	1.28 (32.5)	0.50 (12.7)	99	Pink
60172	500	⅝	5.70 (144.8)	2.00 (50.8)	1.79 (45.5)	0.38 (9.7)	1.28 (32.5)	0.75 (19.0)	99	
60174	600	⅝	5.83 (148.1)	2.00 (50.8)	1.92 (48.8)	0.37 (9.4)	1.36 (34.5)	0.75 (19.0)	106	Black
60176	700	⅝	5.95 (151.1)	2.00 (50.8)	2.04 (51.8)	0.38 (9.7)	1.44 (36.6)	0.75 (19.0)	112	Purple
60178	750	⅝	6.03 (153.2)	2.00 (50.8)	2.13 (54.1)	0.40 (10.2)	1.50 (38.1)	0.75 (19.0)	115	Yellow
60184	1,000	⅝	6.78 (172.2)	2.00 (50.8)	2.50 (63.5)	0.50 (12.7)	1.77 (45.0)	0.75 (19.0)	140	-

Diagram

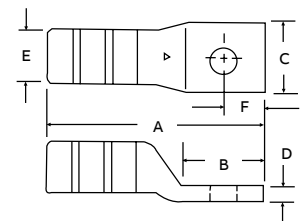

[†] For installations from 16 kV up to 35 kV, consult shielded cable manufacturers for stress relief and insulation requirements. Call your regional sales office for sizes not listed. For tool and die selection charts, see the section E31-E48 of the Tools, Dies and Kits catalogue.

Connectors for aluminum/copper code conductors

Designed and approved for use with both aluminum and copper conductors



Two-hole lugs

- For 90 °C certified to 600 V and recommended up to 35 kV[†] applications
- For aluminum and copper concentric conductors and compact code aluminum strandings
- Filled with oxide-inhibitor compound

Material – High-conductivity wrought aluminum

Finish – Electro tin plated



Two-hole lugs

Cat no.	Cable size (AWG or kcmil)	Bolt size (in.)	Dimensions in. (mm)							Die code	Colour code
			A	B	C	D	E	F	G		
60230	1/0	3/8	3.50 (88.9)	1.90 (48.3)	0.88 (22.4)	0.19 (4.8)	0.62 (15.7)	0.38 (9.7)	1.00 (25.4)	50	Tan
60236	2/0	3/8	3.50 (88.9)	1.90 (48.3)	0.97 (24.6)	0.22 (5.6)	0.70 (17.8)	0.38 (9.7)	1.00 (25.4)	54	Olive
60238	2/0	1/2	5.03 (127.8)	3.41 (86.6)	0.97 (24.6)	0.22 (5.6)	0.70 (17.8)	0.75 (19.1)	1.75 (44.5)	54	Olive
60242	3/0	3/8	3.66 (93.0)	1.18 (30.0)	1.06 (27.0)	0.22 (5.6)	0.77 (19.6)	0.38 (9.7)	1.00 (25.4)	60	Ruby
60244	3/0	1/2	5.16 (131.1)	3.41 (86.6)	0.06 (1.5)	0.22 (5.6)	0.77 (19.6)	0.75 (19.1)	1.75 (44.5)	60	Ruby
60248	4/0	3/8	4.58 (116.3)	1.18 (30.0)	1.21 (30.7)	0.25 (6.4)	0.86 (21.8)	0.38 (9.7)	1.00 (25.4)	66	White
60250	4/0	1/2	5.65 (143.5)	3.41 (86.6)	1.21 (30.7)	0.25 (6.4)	0.86 (21.8)	0.50 (12.7)	1.75 (44.5)	66	White
60254	250	3/8	4.73 (120.1)	1.93 (49.0)	1.29 (32.8)	0.27 (6.9)	0.92 (23.4)	0.38 (9.7)	1.00 (25.4)	71	Red
60256	250	1/2	5.80 (147.3)	3.00 (76.2)	1.29 (32.8)	0.27 (6.9)	0.92 (23.4)	0.50 (12.7)	1.75 (44.5)	71	Red
60260	300	3/8	4.80 (121.9)	1.93 (49.0)	1.39 (35.3)	0.28 (7.1)	0.99 (25.1)	0.38 (9.7)	1.00 (25.4)	76	Blue
60262	300	1/2	5.88 (149.4)	3.00 (76.2)	1.39 (35.3)	0.28 (7.1)	0.99 (25.1)	0.50 (12.7)	1.75 (44.5)	76	Blue
60265	350	3/8	5.50 (139.7)	1.93 (49.0)	1.53 (38.9)	0.33 (8.4)	1.09 (27.7)	0.38 (9.7)	1.00 (25.4)	87	Brown
60267	350	1/2	6.58 (167.1)	3.00 (76.2)	1.53 (38.9)	0.33 (8.4)	1.09 (27.7)	0.50 (12.7)	1.75 (44.5)	87	Brown
60268	400	3/8	5.63 (143.0)	1.93 (49.0)	1.65 (41.9)	0.38 (9.7)	1.18 (30.0)	0.38 (9.7)	1.00 (25.4)	94	Green
60269	400	1/2	6.70 (170.2)	3.00 (76.2)	1.65 (41.9)	0.38 (9.7)	1.18 (30.0)	0.50 (12.7)	1.75 (44.5)	94	Green
60271	500	3/8	5.63 (143.0)	1.93 (49.0)	1.79 (45.5)	0.38 (9.7)	1.28 (32.5)	0.38 (9.7)	1.00 (25.4)	99	Pink
60273	500	1/2	6.70 (170.2)	3.00 (76.2)	1.79 (45.5)	0.38 (9.7)	1.28 (32.5)	0.50 (12.7)	1.75 (44.5)	99	Pink
60274	600	3/8	5.75 (143.1)	1.93 (49.0)	1.92 (48.8)	0.37 (9.4)	1.36 (34.5)	0.38 (9.7)	1.00 (25.4)	106	Black
60275	600	1/2	6.83 (173.5)	3.00 (76.2)	1.92 (48.8)	0.37 (9.4)	1.36 (34.5)	0.50 (12.7)	1.75 (44.5)	106	Black
60276	700	3/8	5.88 (149.4)	1.93 (49.0)	2.04 (51.8)	0.38 (9.7)	1.44 (36.6)	0.38 (9.7)	1.00 (25.4)	112	Purple
60277	700	1/2	6.95 (176.5)	3.00 (76.2)	2.04 (51.8)	0.38 (9.7)	1.44 (36.6)	0.50 (12.7)	1.75 (44.5)	112	Purple
60278	750	1/2	7.15 (181.6)	3.00 (76.2)	2.13 (54.1)	0.40 (10.2)	1.50 (38.1)	0.50 (12.7)	1.75 (44.5)	115	Yellow
60284	1,000	1/2	7.78 (197.6)	3.00 (76.2)	2.50 (63.5)	0.50 (12.7)	1.77 (45.0)	0.50 (12.7)	1.75 (44.5)	140	-

Diagram

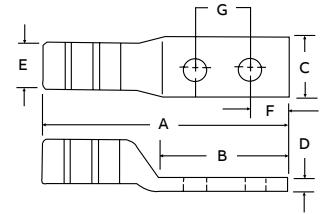

Bolt holes 3/8 in. on 1 in. centers, 1/2 in. on 1 3/4 in. centers.

[†] For installations from 16 kV up to 35 kV, consult shielded cable manufacturers for stress relief and insulation requirements.

For tool and die selection charts, see the section E31-E48 of the Tools, Dies and Kits catalogue.

Connectors for aluminum/copper code conductors



Range-taking narrow-tongue single-barrel lugs

- For 90 °C certified to 600 V and recommended up to 35 kV[†] applications
- Bolt holes on 1³/₄ in. centers
- Wire barrel factory-filled with oxide-inhibitor compound

Material – Aluminum

Finish – Tin-plated



Range-taking narrow-tongue single-barrel lugs

Cat no.	Cable size Al-Cu (kcmil)	Bolt size (in.)	No. of compression hydraulic 12 ton tool or higher	Dimensions in. (mm)					Hex die code	Colour code
				A	B	C	D	E		
60273N	350–500	½	4	6.88 (174.8)	3.13 (79.5)	1.28 (32.5)	0.41 (10.4)	1.50 (38.1)	99H	Pink
60278N	500–750	½	4	7.13 (181.1)	3.69 (93.7)	1.50 (38.1)	0.50 (12.7)	1.50 (38.1)	115H	Yellow
60267NT	350	½	4	6.25 (158.75)	3.00 (76.2)	1.09 (27.68)	0.50 (12.7)	1.09 (27.68)	87H	Brown
60273NT	500	½	3	5.06 (128.52)	3.00 (76.2)	1.18 (30.17)	0.50 (12.7)	1.18 (30.17)	94H	Green
60275NT	600	½	3	5.38 (136.52)	3.00 (76.2)	1.30 (33.14)	0.50 (12.7)	1.30 (33.14)	99H	Pink
60278NT	750	½	3	5.38 (136.52)	3.00 (76.2)	1.03 (26.16)	0.50 (12.7)	1.30 (33.14)	99H	Pink

Diagrams

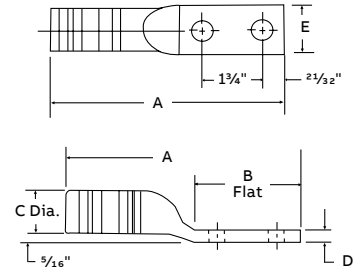

[†] For installations from 16 kV up to 35 kV, consult shielded cable manufacturers for stress relief and insulation requirements. For tool and die selection charts, see the section E31-E48 of the Tools, Dies and Kits catalogue.

Connectors for aluminum/copper code conductors

For aluminum-to-copper or aluminum-to-aluminum splicing



Two-way splice connectors

- Connectors are pre-filled with oxide-inhibitor
- For 90 °C certified to 600 V and recommended up to 35 kV[†] applications
- For aluminum and copper concentric conductors and compact code aluminum strandings
- Permit aluminum conductors to be spliced to copper or aluminum conductors

Material – High-conductivity wrought aluminum

Finish – Electro tin plated



Two-way splice connectors

Cat. no.	Cable size (AWG or kcmil)	Dimensions in. (mm)		Die code	Colour code
		A	E		
60500-TB	#10 Str.	1.00 (25.4)	0.27 (6.9)	21	Red
60501-TB	#8 Str.	1.19 (30.2)	0.28 (7.1)	24	Blue
60507-TB	#6 Str.	1.63 (41.4)	0.35 (8.9)	29	Grey
60512	#4 Str.	1.81 (46.0)	0.46 (11.7)	37	Green
60516	#2 Str./#3 Str.	1.81 (46.0)	0.51 (13.0)	42	Pink
60522-TB	#1 Str.	2.38 (60.5)	0.56 (14.2)	45	Gold
60530-TB	1/0	2.38 (60.5)	0.62 (15.7)	50	Tan
60536	2/0	2.50 (63.5)	0.70 (17.8)	54	Olive
60542	3/0	2.81 (71.4)	0.77 (19.6)	60	Ruby
60548	4/0	3.66 (93.0)	0.86 (21.8)	66	White
60554	250	3.91 (99.3)	0.92 (23.4)	71	Red
60560	300	3.97 (100.8)	0.99 (25.1)	76	Blue
60565	350	4.97 (126.2)	1.09 (27.7)	87	Brown
60568	400	4.97 (126.2)	1.18 (30.0)	94	Green
60571	500	4.97 (126.2)	1.28 (32.5)	99	Pink
60574	600	5.22 (132.6)	1.36 (34.5)	106	Black
60576	700	5.44 (138.2)	1.44 (36.6)	112	Purple
60578	750	5.69 (144.5)	1.50 (38.1)	115	Yellow
60584	1,000	6.69 (169.9)	1.77 (45.0)	140	-

[†] For installations from 16 kV up to 35 kV, consult shielded cable manufacturers for stress relief and insulation requirements. For tool and die selection charts, see the section E31-E48 of the Tools, Dies and Kits catalogue.

Connectors for aluminum/copper code conductors

Splice aluminum conductors to copper conductors of equal ampacities



Aluminum reducing connectors

- For 90 °C, certified to 600 V and recommended up to 35 kV^{*} applications
- Filled with high-temperature oxide-inhibitor compound
- Designed for the right combination of equivalent sizes (example: 4/0 aluminum to 2/0 copper)
- Selection table gives aluminum/copper equivalents to all sizes

Material – High-conductivity wrought aluminum

Finish – Electro tin plated

Installing tools:

TBM5(S) #10 AWG – 4/0 AWG

TBM6(S) #10 AWG – 350 kcmil

TBM8(S) #10 AWG – 350 kcmil



Aluminum reducing connectors

Cat. no.	Cable size (AWG or kcmil)		Dimensions in. (mm)		Die code	Colour key
	Al	Cu	A	E		
60905-TB	#8	#10	0.81 (20.6)	0.28 (7.1)	24	Blue
60910	#6	#8	1.63 (41.4)	0.34 (8.6)	29	Grey
60915	#4	#6	1.81 (46.0)	0.44 (11.2)	37	Green
60925	#1	#3	2.38 (60.5)	0.53 (13.5)	45	Gold
60930	1/0	#2	2.38 (60.5)	0.63 (16.0)	50	Tan
60935	2/0	#1	2.50 (63.5)	0.69 (17.5)	54	Olive
60940	3/0	1/0	2.81 (71.4)	0.75 (19.1)	60	Ruby
60945	4/0	2/0	3.75 (95.3)	0.88 (22.4)	66H	White
60950	250	3/0	4.00 (101.6)	0.94 (23.9)	71H	Red
60955	300	4/0	4.06 (103.4)	1.00 (25.4)	76H	Blue
60960	350	4/0	5.06 (128.5)	0.09 (2.3)	87H	Brown
60965	400	250	5.06 (128.5)	1.22 (31.0)	94H	Green
60970	500	350	5.06 (128.5)	1.31 (33.3)	99H	Pink
60975	600	400	5.31 (134.9)	1.34 (34.0)	106H	Black
60980	700	500	5.56 (141.2)	1.44 (36.6)	112H	Purple
60985	750	500	5.81 (147.6)	1.50 (38.1)	115H	Yellow

Diagram

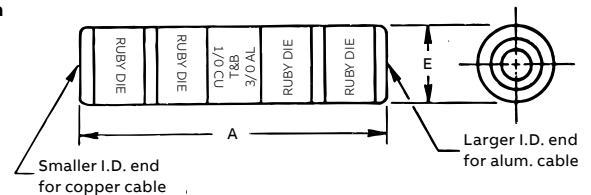

* For installations from 16 kV up to 35 kV, consult shielded cable manufacturers for stress relief and insulation requirements. For tool and die selection charts, see the section E31-E48 of the Tools, Dies and Kits catalogue.

Connectors for aluminum/copper code conductors

Much smaller than standard aluminum lugs for the same cable size

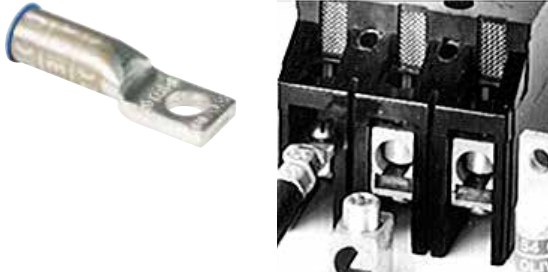

One-hole aluminum compact-size equipment lugs

- For 90°C, certified 600 V applications
- For use with aluminum cables only
- Can be directly substituted for equipment mechanical lugs in most applications
- Only 7 dies handle all 14 lug sizes
- Factory-filled with joint compound
- Electro tin plated
- Supplied with Neoprene insulating covers



One-hole aluminum compact-size equipment lugs

Cat. no.	Aluminum cable (AWG or kcmil) size	Aluminum range (AWG or kcmil) taking*	Bolt hole (in.)	Dimensions in. (mm)					
				A	B	C	D	E	F
61102	#8	-	¼	1.33 (33.8)	0.54 (13.7)	0.50 (12.7)	0.14 (3.6)	0.37 (9.4)	0.25 (6.4)
61107	#6	-	¼	1.33 (33.8)	0.54 (13.7)	0.50 (12.7)	0.14 (3.6)	0.37 (9.4)	0.25 (6.4)
61112	#4	-	¼	1.33 (33.8)	0.54 (13.7)	0.50 (12.7)	0.14 (3.6)	0.37 (9.4)	0.25 (6.4)
61116	#2	-	¼	1.75 (44.5)	0.68 (17.3)	0.55 (14.0)	0.20 (5.1)	0.48 (12.2)	0.25 (6.4)
61122	#1	-	¼	1.75 (44.5)	0.68 (17.3)	0.55 (14.0)	0.20 (5.1)	0.48 (12.2)	0.25 (6.4)
61130	1/0	#8-1/0	⅜	2.00 (50.8)	0.83 (21.1)	0.64 (16.3)	0.20 (5.1)	0.57 (14.5)	0.38 (9.7)
61136	2/0	#1-2/0	⅜	2.00 (50.8)	0.83 (21.1)	0.64 (16.3)	0.20 (5.1)	0.57 (14.5)	0.38 (9.7)
61142	3/0	-	⅜	2.50 (63.5)	1.08 (27.4)	0.78 (19.8)	0.23 (5.8)	0.70 (17.8)	0.38 (9.7)
61148	4/0	2/0-4/0	⅜	2.50 (63.5)	1.08 (27.4)	0.78 (19.8)	0.23 (5.8)	0.70 (17.8)	0.38 (9.7)
61156	250	-	½	2.50 (63.5)	1.23 (31.2)	0.98 (24.9)	0.25 (6.4)	0.85 (21.6)	0.50 (12.7)
61162	300	#4-300	½	2.50 (63.5)	1.23 (31.2)	0.98 (24.9)	0.25 (6.4)	0.85 (21.6)	0.50 (12.7)
61165	350	250-350	½	3.25 (82.6)	1.23 (31.2)	1.20 (30.5)	0.41 (10.4)	1.04 (26.4)	0.56 (14.2)
61171	500	2/0-500	½	3.25 (82.6)	1.23 (31.2)	1.20 (30.5)	0.41 (10.4)	1.04 (26.4)	0.56 (14.2)
61178	750	500-750	⅝	3.75 (95.3)	1.54 (39.1)	1.49 (37.8)	0.41 (10.4)	1.33 (33.8)	0.81 (20.6)

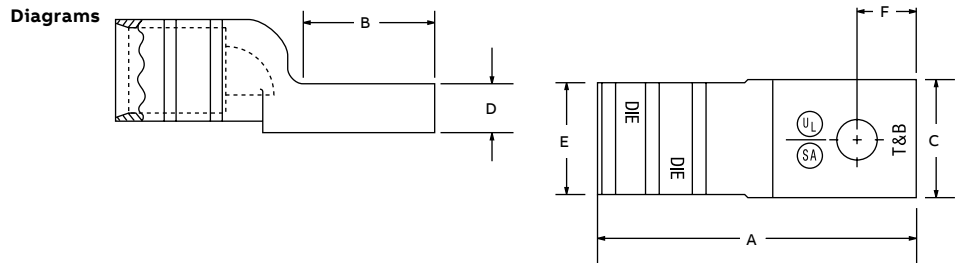

*For range-taking capability, use TBM8-750/TBM8-750M-1 Smart Tools. For tool and die selection charts, see the section E31-E48 of the Tools, Dies and Kits catalogue.

Transformer lug kits for aluminum code conductors

Everything you need to connect to a transformer in one convenient kit



Transformer lug kits

- For 90 °C, certified 600 V applications
- For use with aluminum cables only
- Include all necessary range-taking compression or mechanical-type lugs and bolting hardware to connect to designated transformers
- Lugs pre-filled with oxide inhibitor

Transformer lug kits



Transformer		Al cable (AWG or kcmil) range*	Terminal lugs				Kit contents				Std. pkg.
kVA sizes	Kit cat. no.		Description	Qty.	Nuts	Qty.	Bolts	Qty.	Washers	Qty.	
Compression lugs											
15-37-½ 1Ø	611CL-SK1	#8-1/0	Color-Keyed compression equipment lugs	8	¼-20	8	¼-20 x 1 in.	8	Flat ¼ in. Spring ¼ in.	8	1
15-45 3Ø	611CL-SK1	#4-300	Color-Keyed compression equipment lugs	4	¼-20	8	-	8	Flat ¼ in. Spring ¼ in.	8	1
50-75 1Ø	611CL-SK2	#4-300	Color-Keyed compression equipment lugs	12	¼-20	16	¼-20 x 1 in.	8	Flat ¼ in. Spring ¼ in.	16	1
75-112-½ 3Ø	611CL-SK2	#4-300	Color-Keyed compression equipment lugs	12	¼-20	16	¼-20 x 2 in.	8	Flat ¼ in. Spring ¼ in.	16	1
100-167 1Ø	611CL-SK3	#4-300	Color-Keyed compression equipment lugs	3	¼-20	3	¼-20 x ¾ in.	3	Flat ¼ in. Spring ¼ in.	3	1
150-300 3Ø	611CL-SK3	#2/0-500	Color-Keyed compression equipment lugs	22	¾-16	16	¾-16 x 2 in.	16	Flat ¾ in. Spring ¾ in.	16	1
100-167 1Ø	611CL-SK3-500	#4-300	Color-Keyed compression equipment lugs	3	¼-20	3	¼-20 x 1 in.	3	Flat ¼ in. Spring ¼ in.	3	1
150-300 3Ø	611CL-SK3-500	#2/0-500	Color-Keyed compression equipment lugs	22	¾-16	16	¾-16 x 2 in.	16	Flat ¾ in. Spring ¾ in.	16	1
500 3Ø	611CL-SK4	#500-750	Color-Keyed compression equipment lugs	29	¾-16	18	¾-16 x 2 in.	18	Flat ¾ in. Spring ¾ in.	18	1
Mechanical lugs											
15-37-½ 1Ø	622ML-SK1	#14-2	Mechanical lugs	8	¼-20	8	¼-20 x ¾ in.	8	Flat ¼ in. Spring ¼ in.	8	1
15-45 3Ø	622ML-SK1	#6-250	Mechanical lugs	4	¼-20	-	-	8	Flat ¼ in. Spring ¼ in.	8	1
50-75 1Ø	622ML-SK2	#6-250	Mechanical lugs	12	¼-20	16	¼-20 x ¼ in.	8	Flat ¼ in. Spring ¼ in.	16	1
75-112-½ 3Ø	622ML-SK2	#6-250	Mechanical lugs	12	¼-20	16	¼-20 x 1-¾ in.	8	Flat ¼ in. Spring ¼ in.	16	1
100-167 1Ø	622ML-SK3	#6-250	Mechanical lugs	3	¼-20	3	¼-20 x ¾ in.	3	Flat ¼ in. Spring ¼ in.	3	1
150-300 3Ø	622ML-SK3	350-800	Mechanical lugs	22	¾-16	16	¾-16 x 2 in.	16	Flat ¾ in. Spring ¾ in.	16	1
500 3Ø	622ML-SK4	350-800	Mechanical lugs	29	¾-16	18	¾-16 x 2 in.	18	Flat ¾ in. Spring ¾ in.	18	1

*To ensure proper range-taking compression on Color-Keyed equipment lugs, use Smart Tools (cat. nos. TBM8-750/TBM8-750M-1). For tool and die selection charts, see the section E31-E48 of the Tools, Dies and Kits catalogue.

Pin connectors for aluminum/copper code conductors

Converts an aluminum cable into a two-sizes-smaller copper pigtail



Bi-pin® bi-metal pin connectors

- For 90 °C, 600 V applications
- Upgrades connection by eliminating cold flow and oxidation of aluminum
- Reduces oversized aluminum cable
- Enables termination of aluminum cable into a copper-only lug
- Barrel prefilled with joint compound

Material – Copper wire/aluminum body

Finish – Electro tin plated

Insulator – Neoprene (600 V dielectric rating)



Bi-pin bi-metal pin connectors

Cat. no. insulating covers	Cat. no. heat shrink covers	Aluminum cable size (AWG or kcmil)	Copper wire size (AWG or kcmil)	Body length after installing (in.)	Die code no.	Colour code
61905A	61905AT	#8	#10	1.88	24	Blue
61910A	61910AT	#6	#8	1.88	24	Blue
61915A	61915AT	#4	#6	1.56	45	Gold
61920A	61920AT	#2	#4	1.56	45	Gold
61925A	61925AT	#1	#3	1.63	50	Orange
61930A	61930AT	1/0	#2	1.63	50	Orange
61935	61935T	2/0	#1	1.94	50	Orange
61940	61940T	3/0	1/0	2.13	60	Ruby
61945	61945T	4/0	2/0	2.13	60	Ruby
61950	61950T	250	3/0	2.19	66	White
61955	61955T	300	4/0	2.50	71H	Red
61960	61960T	350	250	2.50	71H	Red
61963	61963T	400	250	3.75	87H	Brown
61965	61965T	500	350	3.75	87H	Brown
61970	61970T	600	400	3.75	107H	Orange
61975	61975T	700–750	500	3.75	107H	Orange

Diagrams

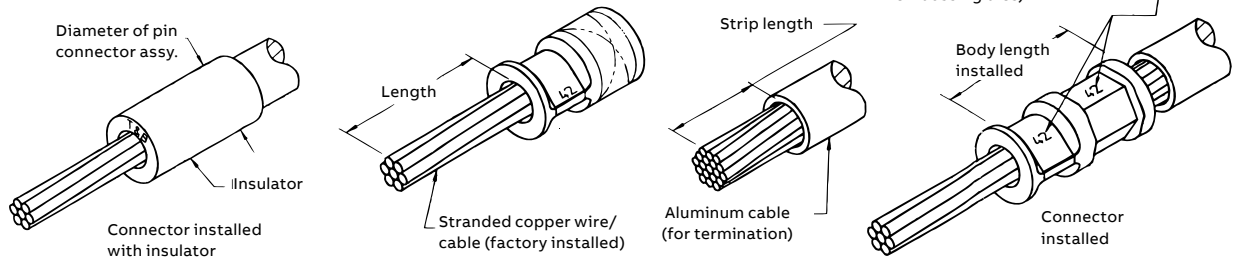

To inspect installation: Match the installing dies to the pin connector permanent embossing. (For tools with code embossing dies)

Insulating covers for H-type compression taps

Quick and easy insulation for H-type compression taps



Interlocking insulating soft covers

- Ideal for pigtail, 2-way splicing or tapping to an unbroken continuous main
- Insulation covers are not reusable

Technical specifications

- Material: Flame-retardant, high-impact polypropylene
- Colour: Black
- Voltage rating: 600 V max.
- Temperature: 90 °C



Interlocking insulating soft covers

Cat. no.	Wire range (AWG or kcmil)		Al H-taps	Use to insulate	Dimensions in. (mm)		
	Max.	Min.			A	B	C
HT20C	2/0	#6	63110/63115 63125/63120	–	4.50 (114.3)	1.25 (31.8)	1.12 (28.4)
HT40C	4/0	#6	63140 63148	–	5.60 (142.2)	1.40 (35.6)	1.18 (30.0)
HT600C	500	#2	63160	63169	6.81 (173.0)	2.12 (53.8)	1.60 (40.6)
HT1000C	1,000–500	250–1/0 AWG	63180	–	7.25 (184.15)	2.330+0.066	–
HT1000C-L		250–250	63170		10.374 (263.40)	2.330+0.066	–

Diagram

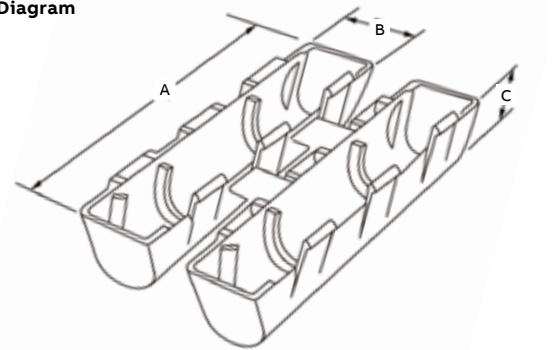

(C) Height – typical both halves

Insulating covers for H-type compression taps



01

01 These insulating covers provide hard-shell insulated protection for "H" type compression taps and splices, and because there is no taping required, you get uniform quality and appearance each time. The exclusive locking design provides the range-taking capability. Only five H-tap insulating catalogue cover numbers accommodate the range of #6 AWG–1000 kcmil in the main, and #12 AWG–500 kcmil in the branch.

For H-tap applications

Cat. no.	Al H-tap	Cu H-tap
HTC2	63105	–
HTC2S	–	CHT814-10
HTC40	63110	CHT214-9
	63118	CHT250214-8
	63125	CHT2514-7
	63140	CHT2502-6
HTC500	63148	CHT50010-5/CHT50040-4
	63160	CHT75010-3/CHT750350-2
HTC1000L	63170	–
HTC1000	63180/63169	CHT750350-1F

Cat. no.	Dimensions in. (mm)		
	A (length)	B (thick)	C (width)
HTC2S	2.00 (50.8)	1.12 (28.4)	1.43 (36.3)
HTC2	3.50 (88.9)	1.12 (28.4)	1.43 (36.3)
HTC40	4.25 (108.0)	1.56 (39.6)	2.00 (50.8)
HTC500	6.00 (152.4)	1.75 (44.5)	2.75 (69.9)
HTC1000	7.00 (177.8)	2.38 (60.5)	3.88 (98.6)
HTC1000L	10.00 (25.4)	2.38 (60.5)	3.88 (98.6)

Interlocking insulating covers for "H" type compression taps.

For use in splice boxes, indoors or in tray indoors.

Place the H-tap in the cover and snap the cover closed.

Consult your regional sales office for flame-retardant version.

Technical data: HTC2 and HTC2S use insulation wrap instead of end cushions for inner seal.

Connector cat. nos. 54755 through 54790 and 63148 through 63180 require hydraulic crimping tools. Refer to instruction sheet.

Materials:

- Outer hard shell covers – High-impact black thermoplastic (Noryl), flammability class, UL 94V-1.

- Inner seal – Black neoprene sponge soft closed cell, oxygen index 28% UL 94 HBF.

Temperature rating – 90 °C maximum.

Certified voltage rating – 600 V maximum.

Note: Insulating covers are not reusable.

Insulating hard covers

- For indoor use in splice boxes and trays
- Easy to use – simply place H-tap in cover and snap cover closed
- Consult your regional sales office for available flame-retardant version
- Hard shell outer covers guard inner seal, keep out dust
- Installs quickly and easily without special tools – simply snaps together
- Eliminate time-consuming taping
- Provide high-quality, neat, uniform installations
- Range-taking design reduces inventory

For C-tap applications

Cat. no.	C-tap	Color code
HTC40	54720	Brown
	54725	Green
	54730	Pink
	54755	Blue
	54760	Brown
HTC40L2	54735	Black
	54740	Orange
	54745	Purple
	54750	Yellow
	54780	White
HTC500	54765	Pink
	54770	Black
	54775	Yellow
	54785	–
HTC1000	54790	–

Dimensions

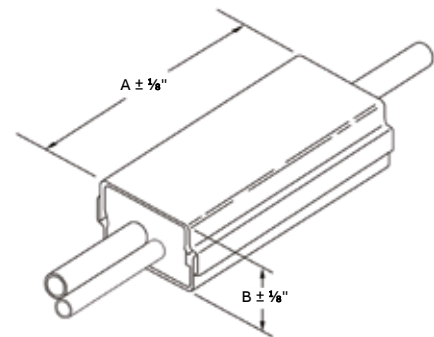

Parallel splices

Ideal for use in transformer and motor/turbine windings



Tools

Cat. no.	Tools
540008	WT-115A, TBM8-750MI, TBM8-780BSCR
540006	TBM8-780M-I, TBM*-750BSCR, ERG2008 (6 AWG die)
540700	TBM8-750M-1, TBM*-750BSCR
540800 – 540900	TBM15I with die 15600X and 15615X
541000	TBM15I with die 15600X and 15604X

Color-Keyed parallel splices offer conductor-splicing solutions for hundreds of OEM, utility and communications applications. They're especially well suited for use in the manufacturing, repair and servicing of windings for transformers, motors, generators and turbines. Rely on them for excellent reliability, long-term performance and a CSA certified connection at a low-installed cost.

- Accommodate multiple wire sizes from #22 AWG to 500 kcmil for application flexibility
- Simple extruded-tube design for ease of use
- Chamfered barrel ends eliminate high-voltage corona and partial discharge failures
- Easy to install with standard compression crimp tools
- 99.9% pure copper for low resistance and high conductivity – tin-plated for corrosion resistance
- Certified for 600 V

Parallel splices



Cat. no.	Min. wire range (AWG or kcmil)	Max. wire range (AWG or kcmil)	Cir. mil range*	Length (in.)	O.D. (in.)	I.D. (in.)	Std. pkg.
540008	#10 & #14	(2) #10	13,000–20,800	0.375	0.260	0.180	5000
540006	(2) #10 & #14	(2) #10 & (3) #14	20,800–33,100	0.500	0.365	0.266	5000
540004	(2) #8 & #14	(2) #6	33,100–52,600	0.531	0.410	0.302	2500
540002	(3) #8 & #14	(2) #4	52,600–83,700	0.640	0.521	0.396	2500
540010	(6) #8	(2) #4 & (1) #6	83,700–119,500	0.750	0.571	0.446	1000
540020	(3) #4	#1 & #2	119,500–150,500	0.750	0.632	0.507	1000
540030	(4) #4	(2) #1 & (2) #10	150,500–190,000	0.750	0.701	0.564	500
540040	(3) #2	1/0 & (3) #4	190,000–231,100	0.770	0.766	0.629	500
540250	3/0 & (4) #8	3/0 & (8) #8	231,100–300,000	1.063	0.926	0.749	250
540300	2/0 & (4) #4	300 & (3) #6	300,000–380,000	1.125	1.100	0.882	100
540400	250 & (5) #6	4/0 & (4) #2	380,000–478,000	1.250	1.200	0.956	100
540500	400 & (3) #6	250 & (13) #6	478,000–600,000	1.438	1.330	1.060	50
540600	(2) 2/0 & (2) 3/0	(2) 4/0 & (2) 2/0	601,800–689,400	1.500	1.500	1.187	60
540700	350, 4/0 & 1/0	(3) 4/0 & (1) 1/0	667,100–740,300	1.531	1.550	1.253	60
540800	(7) 1/0	250, (2) 3/0 & (2) 2/0	738,500–851,800	1.562	1.650	1.353	60
540900	500 & 350	(2) 350 & (1) 250	850,000–950,000	1.625	1.750	1.453	30
541000	(2) 350 & (1) 250	(2) 500 & (1) 3/0	950,000–1,167,800	1.625	1.875	1.578	30

* The total combined cross-sectional area of all wires must be within the circular mil range for the splice.

Heavy-duty battery connectors and tools



Material – High-conductivity copper

Finish – Electro tin plated

Installing tools – TBM5-SV, TBM5V, TBM8250S

Tin-plated straight battery connectors

Cat. no.	Bulk cat. no.	SAE cable size (gauge)	Description	I.D. (in.)	O.D. (in.)	Pkg. qty.	Bulk pkg. qty.	Colour code
BAC4SUBT	BAC4SUBT-C	4	Straight Universal	0.261	0.430	5	100	Grey
BAC2SUBT	BAC2SUBT-C	2	Straight Universal	0.340	0.550	5	100	Green
BAC1SUBT	BAC1SIBT-C	1	Straight Universal	0.340	0.550	5	100	Pink
BAC10SUBT	BAC10SUBT-C	1/0	Straight Universal	0.455	0.625	5	100	Black
BAC20SUBT	BAC20SUBT-C	2/0	Straight Universal	0.502	0.676	5	100	Orange
BAC30SUBT	BAC30SUBT-C	3/0	Straight Universal	0.530	0.730	5	100	Purple
BAC40SUBT	BAC40SUBT-C	4/0	Straight Universal	0.600	0.844	5	100	Yellow
BAC4SPBT	BAC4SPBT-C	4	Straight Positive	0.261	0.430	5	100	Grey
BAC4SNBT	BAC4SNBT-C	4	Straight Negative	0.261	0.430	5	100	Grey
BAC2SPBT	BAC2SPBT-C	2	Straight Positive	0.340	0.550	5	100	Green
BAC2SNBT	BAC2SNBT-C	2	Straight Negative	0.340	0.550	5	100	Green
BAC1SPBT	BAC1SPBT-C	1	Straight Positive	0.340	0.550	5	100	Pink
BAC1SNBT	BAC1SNBT-C	1	Straight Negative	0.340	0.550	5	100	Pink
BAC10SPBT	BAC10SPBT-C	1/0	Straight Positive	0.455	0.625	5	100	Black
BAC10SNBT	BAC10SNBT-C	1/0	Straight Negative	0.455	0.625	5	100	Black
BAC20SPBT	BAC20SPBT-C	2/0	Straight Positive	0.502	0.676	5	100	Orange
BAC20SNBT	BAC20SNBT-C	2/0	Straight Negative	0.502	0.676	5	100	Orange
BAC30SPBT	BAC30SPBT-C	3/0	Straight Positive	0.530	0.730	5	100	Purple
BAC30SNBT	BAC30SNBT-C	3/0	Straight Negative	0.530	0.730	5	100	Purple
BAC40SPBT	BAC40SPBT-C	4/0	Straight Positive	0.600	0.844	5	100	Yellow
BAC40SNBT	BAC40SNBT-C	4/0	Straight Negative	0.600	0.844	5	100	Yellow

Diagrams

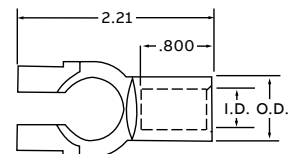
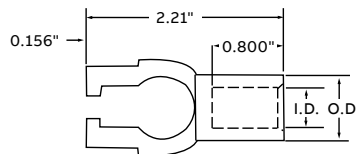

Heavy-duty battery connectors and tools



Material – High-conductivity copper

Finish – Electro tin plated

Installing tools – TBM5-SV, TBM5V

Tin-plated flag battery connectors

Cat. no.	Bulk cat. no.	SAE cable size (gauge)	Description	I.D. (in.)	O.D. (in.)	Pkg. qty.	Bulk pkg. qty.	Colour code
BAC10FU	BAC10FNBL	1/0	Flag Universal	0.455	0.625	5	100	Black
BAC20FU	BAC20FNBL	2/0	Flag Universal	0.502	0.676	5	100	Orange
BAC30FU	BAC30FNBL	3/0	Flag Universal	0.530	0.730	5	100	Purple
BAC40FU	BAC40FNBL	4/0	Flag Universal	0.600	0.844	5	100	Yellow
BAC10FPBT	BAC10FPBT-C	1/0	Flag Positive	0.455	0.625	5	100	Black
BAC10FNBT	BAC10FNBT-C	1/0	Flag Negative	0.455	0.625	5	100	Black
BAC20FPBT	BAC20FPBT-C	2/0	Flag Positive	0.502	0.676	5	100	Orange
BAC20FNBT	BAC20FNBT-C	2/0	Flag Negative	0.502	0.676	5	100	Orange
BAC30FPBT	BAC30FPBT-C	3/0	Flag Positive	0.530	0.730	5	100	Purple
BAC30FNBT	BAC30FNBT-C	3/0	Flag Negative	0.530	0.730	5	100	Purple
BAC40FPBT	BAC40FPBT-C	4/0	Flag Positive	0.600	0.844	5	100	Yellow
BAC40FNBT	BAC40FNBT-C	4/0	Flag Negative	0.600	0.844	5	100	Yellow

Diagram

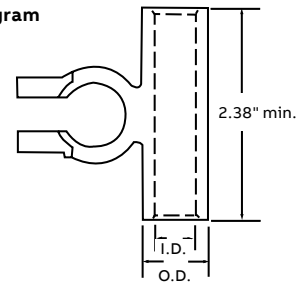

Heavy-duty battery connectors and tools



Material – High-conductivity copper

Finish – Electro tin plated

Installing tools – TBM5-SV, TBM5V

Tin-plated elbow battery connectors

Cat. no.	Bulk cat. no.	SAE cable size (gauge)	Description	I.D. (in.)	O.D. (in.)	Pkg. qty.	Bulk pkg. qty.	Colour code
BAC10ERNBT	BAC10ERNBT-C	1/0	Right Elbow–Negative	0.455	0.625	5	100	Black
BAC10ERPBT	BAC10ERPBT-C	1/0	Right Elbow–Positive	0.455	0.625	5	100	Orange
BAC20ERNBT	BAC20ERNBT-C	2/0	Right Elbow–Negative	0.502	0.676	5	100	Purple
BAC20ERPBT	BAC20ERPBT-C	2/0	Right Elbow–Positive	0.502	0.676	5	100	Yellow
BAC30ERNBT	BAC30ERNBT-C	3/0	Right Elbow–Negative	0.530	0.730	5	100	Black
BAC30ERPBT	BAC30ERPBT-C	3/0	Right Elbow–Positive	0.530	0.730	5	100	Orange
BAC40ERNBT	BAC40ERNBT-C	4/0	Right Elbow–Negative	0.600	0.844	5	100	Purple
BAC40ERPBT	BAC40ERPBT-C	4/0	Right Elbow–Positive	0.600	0.844	5	100	Yellow
BAC10ELNBT	BAC10ELNBT-C	1/0	Left Elbow–Negative	0.455	0.625	5	100	Black
BAC10ELPBT	BAC10ELPBT-C	1/0	Left Elbow–Positive	0.455	0.625	5	100	Orange
BAC20ELNBT	BAC20ELNBT-C	2/0	Left Elbow–Negative	0.502	0.676	5	100	Purple
BAC20ELPBT	BAC20ELPBT-C	2/0	Left Elbow–Positive	0.502	0.676	5	100	Yellow
BAC30ELNBT	BAC30ELNBT-C	3/0	Left Elbow–Negative	0.530	0.730	5	100	Black
BAC30ELPBT	BAC30ELPBT-C	3/0	Left Elbow–Positive	0.530	0.730	5	100	Orange
BAC40ELNBT	BAC40ELNBT-C	4/0	Left Elbow–Negative	0.600	0.844	5	100	Purple
BAC40ELPBT	BAC40ELPBT-C	4/0	Left Elbow–Positive	0.600	0.844	5	100	Yellow

Diagram

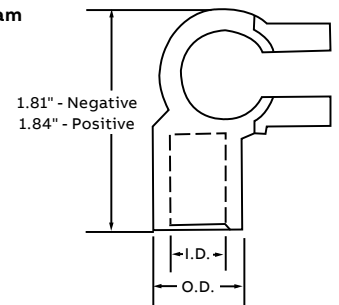

Heavy-duty battery connectors and tools



Material – High-conductivity copper
Finish – Lead-plated
Installing tools – TBM5-SV or TBM5V

Stackable battery connectors – Lead-plated

Cat. no.	Bulk cat. no.	SAE cable size (gauge)	Dimensions in. (mm)					Stud size (in.)	Pkg. qty.	Bulk pkg. qty.	Colour code
			A ±0.040	M ±0.020	W ±0.020	C ±0.020	E ±0.010				
BAC438	273-31853-1	4	1.46 (37.0)	1.14 (29.0)	0.62 (15.6)	0.75 (19.1)	0.37 (9.3)	3/8	10	100	Grey
BAC238	273-31853-2	2	1.78 (45.1)	1.40 (35.6)	0.68 (17.1)	0.85 (21.6)	0.47 (11.9)	3/8	10	100	Green
BAC138	273-31853-3	1	1.88 (47.6)	1.50 (38.1)	0.75 (44.5)	0.95 (24.1)	0.52 (13.2)	3/8	10	100	Pink
BAC1038	273-31853-4	1/0	1.93 (48.9)	1.55 (39.4)	0.83 (21.0)	1.00 (25.4)	0.57 (14.5)	3/8	10	100	Black
BAC2038	273-31853-5	2/0	2.11 (53.6)	1.65 (41.8)	0.93 (23.6)	1.10 (27.9)	0.63 (16.1)	3/8	10	100	Orange
BAC3038	273-31853-6	3/0	2.03 (51.4)	1.65 (41.9)	1.03 (26.0)	1.10 (27.9)	0.70 (17.8)	3/8	10	100	Purple
BAC4038	273-31853-7	4/0	2.23 (57.8)	1.90 (48.3)	1.03 (26.0)	1.35 (34.3)	0.77 (19.5)	3/8	10	100	Yellow

Diagram

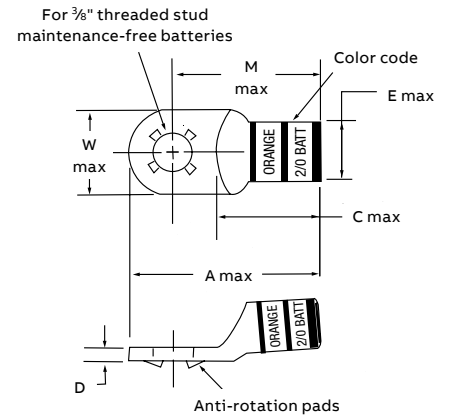

Heavy-duty battery connectors and tools



Material – High-conductivity copper

Finish – Electro tin plated

Installing tools – TBM5-SV or TBM5V



Starter lugs – Tin-plated

Cat. no.	Bulk cat. no.	SAE cable size (gauge)	Stud size (in.)	Dimensions (mm)				Pkg. qty.	Bulk pkg. qty.	Colour code
				A ±0.04	B ±0.02	C ±0.02	D ±0.02			
BAL414	273-31852-1	4	¼	140	52	40	115	10	100	Grey
BAL4516	273-31852-2	4	¼	145	61	363	114	10	100	
BAL438	273-31852-3	4	¾	145	61	6	114	10	100	
BAL2516	–	2	¼	159	69	40	1258	10	–	Green
BAL238	273-31852-4	2	¾	178	67	55	140	10	100	
BAL212	273-31852-5	2	½	177	76	54	140	10	100	Pink
BAL1516	–	1	¼	183	76	49	150	10	–	
BAL138	273-31852-6	1	¾	185	75	55	150	10	100	
BAL112	273-31852-7	1	½	220	75	75	170	10	100	Black
BAL10516	–	1/0	¼	192	83	50	150	10	–	
BAL1038	273-31852-8	1/0	¾	193	83	55	155	10	100	
BAL1012	273-31852-9	1/0	½	197	88	53	153	10	100	Orange
BAL20516	–	2/0	¼	206	93	50	160	10	–	
BAL2038	273-31852-10	2/0	¾	211	93	55	165	10	100	
BAL2012	273-31852-11	2/0	½	211	93	55	165	10	100	Purple
BAL30516	–	3/0	¼	216	103	55	165	10	–	
BAL3038	273-31852-12	3/0	¾	203	103	55	165	10	100	
BAL3012	273-31852-13	3/0	½	235	103	75	185	10	100	Yellow
BAL40516	–	4/0	¼	240	113	59	184	10	–	
BAL4038	273-31852-14	4/0	¾	228	112	55	190	10	100	
BAL4012	273-31852-15	4/0	½	260	112	75	210	10	100	

Diagram

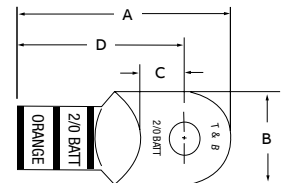

Heavy-duty battery connectors and tools



Material – High-conductivity copper

Finish – Electro tin plated

Installing tools – TBM5-SV or TBM5V

Splices (two-way connectors)

Cat. no.	Bulk cat. no.	SAE cable size (gauge)	Pkg. qty.	Bulk pkg. qty.	Colour code
BAS4	273-31852-16	4	10	100	Grey
BAS2	273-31852-17	2	10	100	Green
BAS1	273-31852-18	1	10	100	Pink
BAS10	273-31852-19	1/0	10	100	Black
BAS20	273-31852-20	2/0	10	100	Orange
BAS30	273-31852-21	3/0	10	100	Purple
BAS40	273-31852-22	4/0	10	100	Yellow



Material – High-conductivity copper

Finish – Electro tin plated

Installing tools – TBM5-SV or TBM5V

Insulating cover – AC5X3

“Y” splices

Cat. no.	Strip cable size	SAE cable size (gauge)	Length (in.)	Colour code
BASY20	2/0-(2) #2	2/0	¾	Orange
BASY30	3/0-(2) #1	3/0	¾	Purple
BASY40	4/0-(2) 1/0	4/0	¾	Yellow

Heavy-duty battery connectors and tools

Abrasion-resistant and engineered for optimum performance at both high and low temperatures



Battery/starter cables

- Fine flexible copper rope stranding PVC jacket conforms to SAE J1127 specifications
- Layer of paper separates insulation from copper, providing easy stripping with no stranding damage
- Temperature-rated for 80 °C
- Flexibility ideal for tight spaces and cold environments
- Color-Keyed markings for fast and accurate identification
- Marked in 1-ft. increments for easy measurement
- Available in red or black jacket colour

Material – High-conductivity copper

Finish – Electro tin plated

Installing tools – TBM5-SV or TBM5V

Battery/starter cables

Cat. no.	SAE cable size (gauge)	Cable length (ft.)	Cable colour
BC4-100	4	100	Black
BC2-100	2	100	Black
BC1-100	1	100	Black
BC10-100	1/0	100	Black
BC20-100	2/0	100	Black
BC30-100	3/0	100	Black
BC40-100	4/0	100	Black
BC4-1000	4	1,000	Black
BC2-500	2	500	Black
BC1-500	1	500	Black
BC10-500	1/0	500	Black
BC20-500	2/0	500	Black
BC30-500	3/0	500	Black
BC40-500	4/0	500	Black
BC4-1000R	4	1,000	Red
BC2-500R	2	500	Red
BC1-500R	1	500	Red
BC10-500R	1/0	500	Red
BC20-500R	2/0	500	Red
BC30-500R	3/0	500	Red
BC40-500R	4/0	500	Red

Cat. no.	SAE cable size (gauge)	Cable length (ft.)	Cable colour
BC4-25	4	25	Black
BC2-25	2	25	Black
BC1-25	1	25	Black
BC10-25	1/0	25	Black
BC20-25	2/0	25	Black
BC30-25	3/0	25	Black
BC40-25	4/0	25	Black
BC4-25R	4	25	Red
BC2-25R	2	25	Red
BC1-25R	1	25	Red
BC10-25R	1/0	25	Red
BC20-25R	2/0	25	Red
BC30-25R	3/0	25	Red
BC40-25R	4/0	25	Red

Heavy-duty battery cable

Specially designed for demanding industrial and OEM requirements



- 105 °C Temperature-rated and UL recognized
- Heavier PVC jacket conforms to SAE J1127 specifications
- Color-Keyed markings for fast and accurate identification
- Marked in 1-ft. increments for easy measurement

- Layer of paper separates insulation from copper for easy stripping with no strand damage
- 600 V rated available in bulk only
- Application-specific – To order, contact your regional sales offices

Heavy-duty battery connectors and tools



BCT840, BCT840S



TBM5SV, TBM5V

BCT840, BCT840S:

- Adjustable die crimping tools for Color-Keyed cast and tubular connectors
- The single die is an integral part of the tool; no dies to lose or misplace
- Available with Shure Stake mechanism to ensure a complete crimp every time (BCT840S)
- Crimp casting and tubular connectors ranging from #4 to 4/0 AWG

TBM5SV, TBM5V:

- Heavy-duty crimping tool including dies for #8–4/0 AWG battery connectors, lugs and splices
- Available with Shure Stake mechanism to ensure a complete crimp every time (TBM5S)

Crimping tools

Cat. no.	Description	Pkg. qty.
BCT840	Dieless crimp tool for cast and tubular battery connectors	1
BCT840S	Dieless crimp tool with Shure-Stake mechanism for cast and tubular battery connectors	1
TBM5V	Ratchet crimp tool with die for #8 to 4/0 AWG battery connectors	1
TBM5-SV	Ratchet crimp tool with Shure-Stake mechanism and die for #8 to 4/0 AWG battery connectors	1



- Cuts cable up to 500 kcmil
- Fiberglass handles and carbon steel blades
- For copper and aluminum cable only

Cable cutter

Cat. no.	Description	Pkg. qty.
364RF	Cutter for up to 500 kcmil copper and aluminum	1

Contact Tool Service for replacement blades.



Cable stripper

Cat. no.	Description	Pkg. qty.
BCS8-40	Cable stripper for #8 to 4/0 AWG battery cable with replacement blade provided in the handle	1

Accessories and miscellaneous hardware

Copper colloidal surface treatment protects, lubricates and enhances conductivity of all electrical connections



- Unique, homogenized blend of pure, polished colloidal copper, rust and corrosion inhibitors
- Simultaneously protects, lubricates and enhances conductivity of mating surfaces
- Extremely adhesive compound flows smoothly into uneven contours and voids, ensuring easy application and complete, positive protection and lubrication
- Won't settle out, thin, thicken, harden or dry out under the most severe environmental conditions
- Excellent temperature characteristics– can be brushed on at -45.5 °C (-50 °F) to 121 °C (250 °F) (other compounds either turn solid or run like water at these extremes) and remains intact at short terms even at 980 °C (1,800 °F)

Good connections are one of the most important aspects of electrical work. Mechanics know how much downtime is caused when fluids or oils leak into the raceway system or when they have to look for a weak link in a ground system caused by a high-resistance connection. Mechanics also know how much time is spent keeping contacts, switches, lugs and other connectors clean or replacing parts because of “green scourage” buildup. ABB has the solution to improve connections made in thousands of electrical and

raceway installations made each day by electricians everywhere. Kopr-Shield® compound may be used to advantage in all electrical installations. When the environment is hostile to electrical and mechanical connections, Kopr-Shield compound is a must.

Use Kopr-Shield compound for battery lugs and cables to:

- Prevent “green scourage” corrosion
- Reduce resistance
- Ease terminal installation and removal

Use Kopr-Shield compound for raceways to:

- Lubricate for ease of assembly and disassembly
- Improve grounding continuity (exceeds code requirements)

Use Kopr-Shield compound for fuse clips to:

- Eliminate hot spots for even heat distribution
- Prevent oxidation by preventing carbon path formation
- Lubricate for easy installation and removal of fuses

Use Kopr-Shield compound for wiping contacts, drum switches and slip rings to:

- Prevent galling, burning, pitting and discoloration
- Suppress arcing and dissipation of coronas
- Lubricate for ease of operation

Kopr-Shield joint compound

Cat. no.	Description	Std. pkg.	Weight lb/C
201-31879	1½-oz. Container with brush	96	11.46
201-31879-1	4-oz. Container with brush	24	38.54
CP8-TB	8-oz. Container with brush	12	64.58
CP16	16-oz. Container with brush	12	120.83
CP128	1-Gallon can	4	952.00



ALUMA-SHIELD aluminum joint compound



Cat. no.	Contains	Description
21059	1-pt. Squeeze bottle	For aluminum cable connections; contains fine zinc particles which break through oxide film on cable strands upon compression of connection; ensures a low resistance contact and seals out air and moisture.
AP8	8-oz. Brush cap can	
M53	5-Gallon can	

Accessories and miscellaneous hardware



Belleville compression washers

- Essential when bolting aluminum lugs and connectors to bus bars with steel or brass hardware
- Maintain constant pressure in heavy-duty, high-temperature applications
- Available with or without flat washer

When bolting aluminum lugs and connectors to bus bars with steel or brass hardware, the recommended practice to ensure a tight connection is to use a Belleville spring washer on top of a flat washer under the bolt head or nut. For heavy-duty service where the heat rise is expected to exceed 30 °C above ambient, this procedure maintains constant pressure as the connector metals expand and contract with temperature changes.

Belleville compression washers

Cat. no.	Bolt size (in.)	O.D.	Dimensions in. (mm)		
			Flat washer Thickness	Belleville washer O.D.	Belleville washer Thickness
Belleville compression washers plus flat washer					
60800B	¼	0.75 (19.1)	0.07 (1.8)	0.69 (17.5)	0.06 (1.5)
60801B	5/16	0.88 (22.1)	0.07 (1.8)	0.81 (20.6)	0.07 (1.8)
60802B	¾	1.00 (25.4)	0.08 (2.0)	0.94 (23.9)	0.08 (2.0)
60803B	½	1.25 (31.8)	0.11 (2.8)	0.81 (20.6)	0.10 (2.5)
Belleville compression washer only					
60800	¼	–	–	0.69 (17.5)	0.06 (1.5)
60801	5/16	–	–	0.81 (20.6)	0.07 (1.8)
60802	¾	–	–	0.94 (23.9)	0.08 (2.0)
60803	½	–	–	0.81 (20.6)	0.10 (2.5)
60804	5/8	–	–	1.50 (38.1)	0.11 (2.8)

Diagram

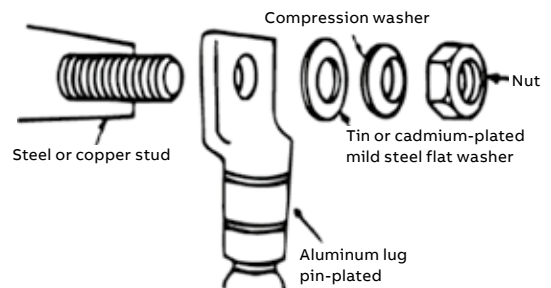

Note: Ordering quantity must be in unit quantities and multiples thereof.

The Belleville washer should be installed with a larger flat washer to spread the high stresses of the compression washer edges over a large area of the lug and/or bus bar.



Dragon Tooth® transition washers

Quick, dependable and versatile.

- Connect copper-to-aluminum, copper-to-copper or aluminum-to-aluminum components
- Toothed surface penetrates aluminum and copper oxides
- Lower installed cost – no need to grind aluminum surfaces, apply compounds or use spring-type washers

Dragon Tooth transition washers

Cat. no.	Size (in.)	Bolt torque (in.-lb)
DTW14	¼	50–80
DTW516	5/16	125–160
DTW38	¾	160–240
DTW12	½	390–540
DTW58	5/8	540–730

Accessories and miscellaneous hardware



Hex head bolts and nuts

Cat. no.				
Diameter and threads per inch				
¼ in.-20	⅝ in.-18	¾ in.-16	½ in.-13	Length (in.)
Type BB — Silicon bronze hex head bolts				
25100BB-C	31100BB-C	37100BB-C	50100BB-C	1
-	31125BB-C	37125BB-C	50125BB-C	1¼
-	31150BB-C	37150BB-C	50150BB-C	1½
-	31175BB-C	37175BB-C	50175BB-C	1¾
-	31200BB-C	37200BB-C	50200BB-C	2
25225BB-C	31225BB-C	37225BB-C	50225BB-C	2¼
-	31250BB-C	37250BB-C	50250BB-C	2½
-	31275BB-C	37275BB-C	50275BB-C	2¾
-	31300BB-C	37300BB-C	50300BB-C	3
-	-	37325BB-C	50325BB-C	3¼
-	-	37350BB-C	50350BB-C	3½
Type HN — Silicon bronze hex nuts				
14010HN-C	31010HN-C	37010HN-C	50010HN-C	-



Washers

Cat. No.	Bolt size (in.)	O.D. (in.)	I.D. (in.)	Thickness (in.)	Height (in.)
Type SW — Silicon bronze split lock washers					
14030SW-C	¼	-	-	-	-
31030SW-C	⅝	-	-	-	-
37030SW-C	¾	-	-	-	-
50030SW-C	½	-	-	-	-
Type FW — Silicon bronze flat washers					
14040FW-C	¼	¼	11/16	0.260	0.040
31040FW-C	⅝	⅝	7/8	0.336	0.064
37040FW-C	¾	¾	1	0.395	0.064
50040FW-C	½	½	1¼	0.562	0.091
Type BW — Belleville compression washer 304 series stainless steel					
50050BW-C	½	1⅞	17/32	0.062	1/8

Accessories and miscellaneous hardware

Sealants and lubricants



Type CT — CONTAX™ oxide inhibiting compound

- Seals electrical connections from oxygen and moisture
- Non-water soluble, non-petroleum based polymer grease
- Nontoxic, will not irritate the skin
- Service temperature to 238 °C (460 °F); can be applied in -18 °C (0 °F) weather

Cat. no.	Description
CTA	½ oz. Package
CTB	4 oz. Plastic bottle
CTB8	8 oz. Plastic bottle
CTQ	Quart can
CTG	Gallon can



Type DX — Duct seal

- Seals around junction boxes, flashings, service mast entries, service cable entries and countless other applications
- Easy to use, forms around irregular surfaces and configurations
- Highly resistant to cracking, drying and shrinking
- Cuts and trims easily
- Can be painted immediately after application
- Grey colour
- No unpleasant odor
- -6.7 °C to 100 °C (20 °F to 212 °F) workable temperature range
- -40 °C to 121 °C (-40 °F to 250 °F) service temperature range
- Contains no asbestos

Cat. no.	Description
DX-1	1 lb Slug
DX-5	(5) 1 lb Slugs
DX-5S	5 lb Slug



Silicone lubricant for high voltage electrical work



Cat. No.	Description	Pkg. qty.
2012	2 grams	250 tubes
2015	5 grams	100 tubes
SL5	5 oz./142 grams	12 tubes



Type WW — Wire bristle brush

- Removes oxides from conductor surfaces
- Easy-grip handle with guard to prevent rubber-glove puncture
- Replaceable long-life brushes can be rotated
- Handle and guard coated with durable, nonconductive plastic for safety

Cat. No.	Description	Pkg. qty.
WWB1	Complete brush with handle	1
WRB1	Brush replacement	1